

Sysmac Library for NJ/NX/NY Controller

SYSMAC-XR003

MC Tool Box Library



✓ Easily connect an inverter to a PLC to drive a general-purpose motor.

- Issue 1** If an inverter is installed near a motor, the wiring can be complicated due to the long distance between the inverter and PLC.
- Issue 2** When an induction motor is used for speed control and simple positioning, it takes time to create a feedback control program.

MC Tool Box Library offers solution!

The NJ/NX Machine Automation Controller and the NY Industrial PC Platform can be connected to inverters and I/O devices via EtherCAT using LAN cables, which makes wiring simple. Stable control can be achieved by combining Function Blocks in this library even when an inverter is used.

System configuration

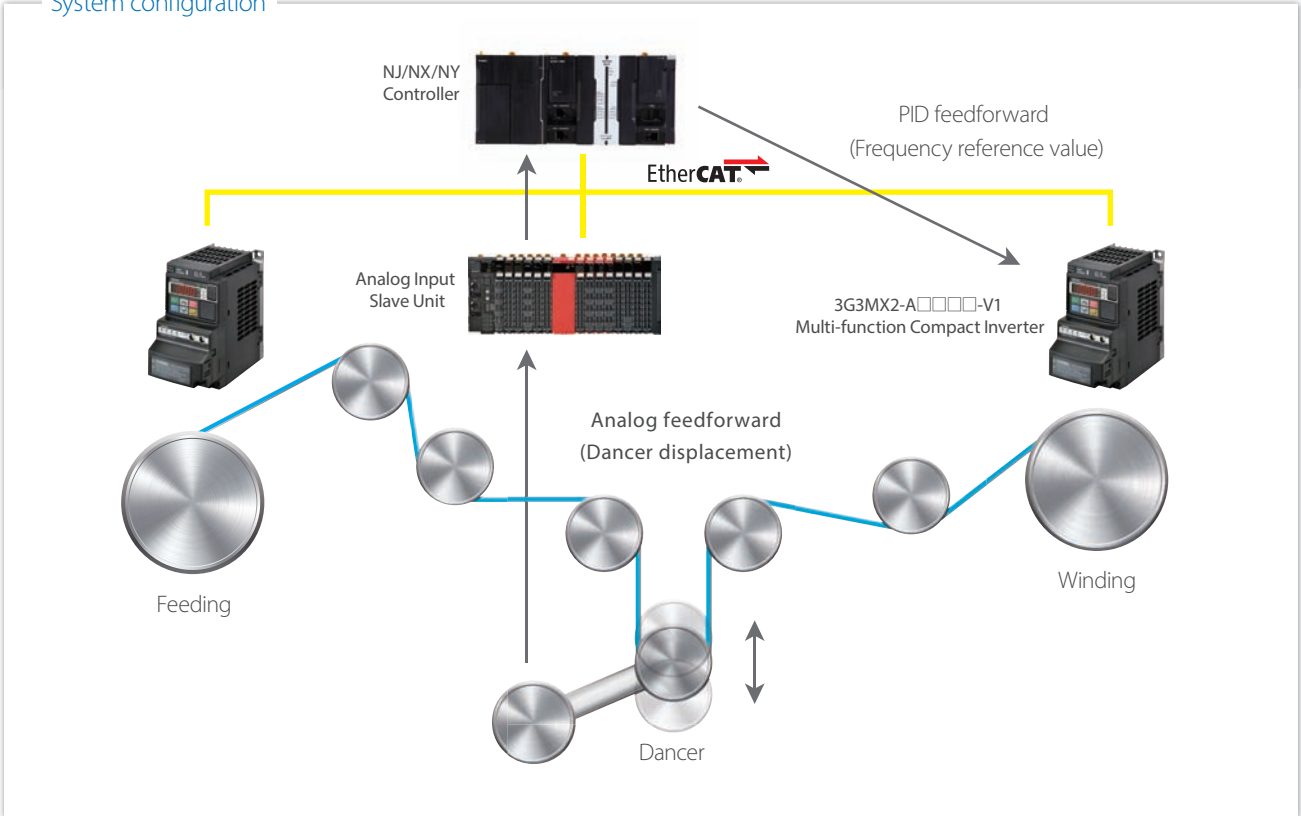

[Example] Tension control program using the MC Tool Box Library

NJ/NX/NY Controller

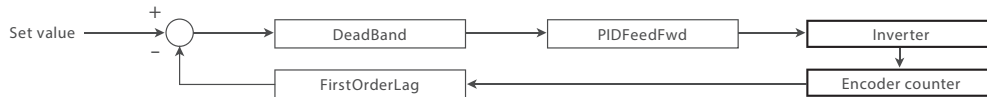

From

The motor speed quickly reaches the set speed but is not constant (= inconsistent tension).

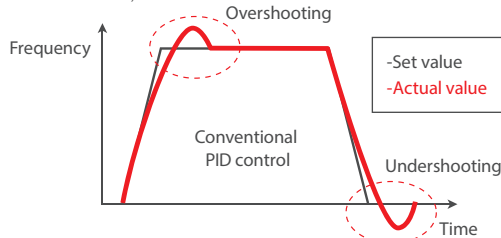

To

The motor speed quickly reaches the set speed and is constant (= constant tension).

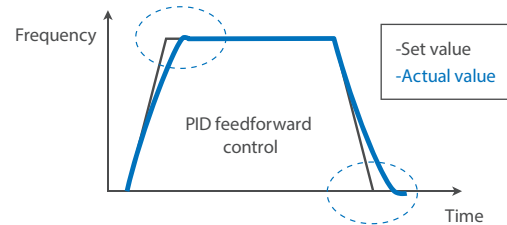

The NJ/NX/NY Controller executes sequence control, motion control, and I/O refreshing in the same control period. The calculation results of feedback control can be output in a short fixed cycle. This means the motor can constantly receive commands.

Compatible Models

Name	Model	Version
Machine Automation Controller NJ/NX CPU Unit	NX701-1□□□/NJ101-□□□□	Version 1.10 or later
	NJ501-□□□□/NJ301-□□□□	Version 1.08 or later
	NX1P2-□□□□□□(1)	Version 1.13 or later
	NX102-□□□□	Version 1.30 or later
	NX502-□□□□	Version 1.60 or later
Industrial PC Platform NY IPC Machine Controller	NY5□□-1	Version 1.12 or later
	NY5□□-5	Version 1.18 or later
Automation Software Sysmac Studio	SYSMAC-SE2□□□	Version 1.14 or higher
MX2-V1 Multi-function Compact Inverter	3G3MX2-A□□□□-V1	Version 1.00 or later

Function Block (FB) Specifications

Name	FB name	Description
PID Feedforward	PIDFeedFwd	Performs PID feedforward processing according to a specified parameter table.
First Order Lag	FirstOrderLag	Processes a first order lag according to a specified parameter table.
Phase Lead Lag	LeadLag	Performs phase lead lag processing according to a specified parameter table.
Deadband Control without Output Offset	DeadBand	Controls a deadband that does not create an offset with the processing result.

Sysmac is a trademark or registered trademark of OMRON Corporation in Japan and other countries for OMRON factory automation products. EtherCAT® is registered trademark and patented technology, licensed by Beckhoff Automation GmbH, Germany. EtherNet/IP™ is a trademark of the ODVA. Other company names and product names in this document are the trademarks or registered trademarks of their respective companies.

Note: Do not use this document to operate the Unit.

OMRON Corporation Industrial Automation Company

Kyoto, JAPAN

Contact : www.ia.omron.com

Regional Headquarters

OMRON EUROPE B.V.

Wegalaan 67-69, 2132 JD Hoofddorp
The Netherlands
Tel: (31) 2356-81-300 Fax: (31) 2356-81-388

OMRON ELECTRONICS LLC

2895 Greenspoint Parkway, Suite 200
Hoffman Estates, IL 60169 U.S.A.
Tel: (1) 847-843-7900 Fax: (1) 847-843-7787

OMRON ASIA PACIFIC PTE. LTD.

438B Alexandra Road, #08-01/02 Alexandra
Technopark, Singapore 119968
Tel: (65) 6835-3011 Fax: (65) 6835-3011

OMRON (CHINA) CO., LTD.

Room 2211, Bank of China Tower,
200 Yin Cheng Zhong Road,
PuDong New Area, Shanghai, 200120, China
Tel: (86) 21-6023-0333 Fax: (86) 21-5037-2388

Authorized Distributor:

©OMRON Corporation 2015-2023 All Rights Reserved.
In the interest of product improvement,
specifications are subject to change without notice.

CSM_2_3

Cat. No. P098-E1-03 0523(1115)