

Programmable Multi Axis Controller

PMAC Series



- World-beating* output speeds — Extremely precise motion control
- Flexible function development capability — More creative
- Multi-vendor compatibility — Create the right system for your application

* Refers to the motion control performance of 16.6 μ s/1 axes or 50 μ s/8 axes (Omron survey as of July 2016).

More flexible, more open — Programmable Multi Axis Controller "PMAC"

Omron keeps believing in human potential

In order to satisfy diverse consumer needs and deal with short product life cycles, manufacturers need to boost both their productivity and their manufacturing quality. Omron is doing so by adopting the latest precision machining and robotics technologies.

More open technology will help customers turn their ideas into reality to flexibly respond to future changes —

That's why Omron developed
the Programmable Multi Axis Controller (PMAC).

The PMAC delivers world-beating* output speeds and flexibility that allows you to achieve your creative ideas.

Turn your ideas into a real machine, and enrich the lives of people around the world through products made by your machine.

The PMAC was originally created by Delta Tau Data Systems, Inc., which joined the Omron family in September 2015, and was further developed by adding Omron's philosophy and technology. Its potential is unlimited — it's up to you in how you use it.

* Refers to the motion control performance of 16.6 μ s/1 axes or 50 μ s/8 axes (Omron survey as of July 2016).

PMAC series

Programmable Multi Axis Controller

The controller meets the needs of the times.

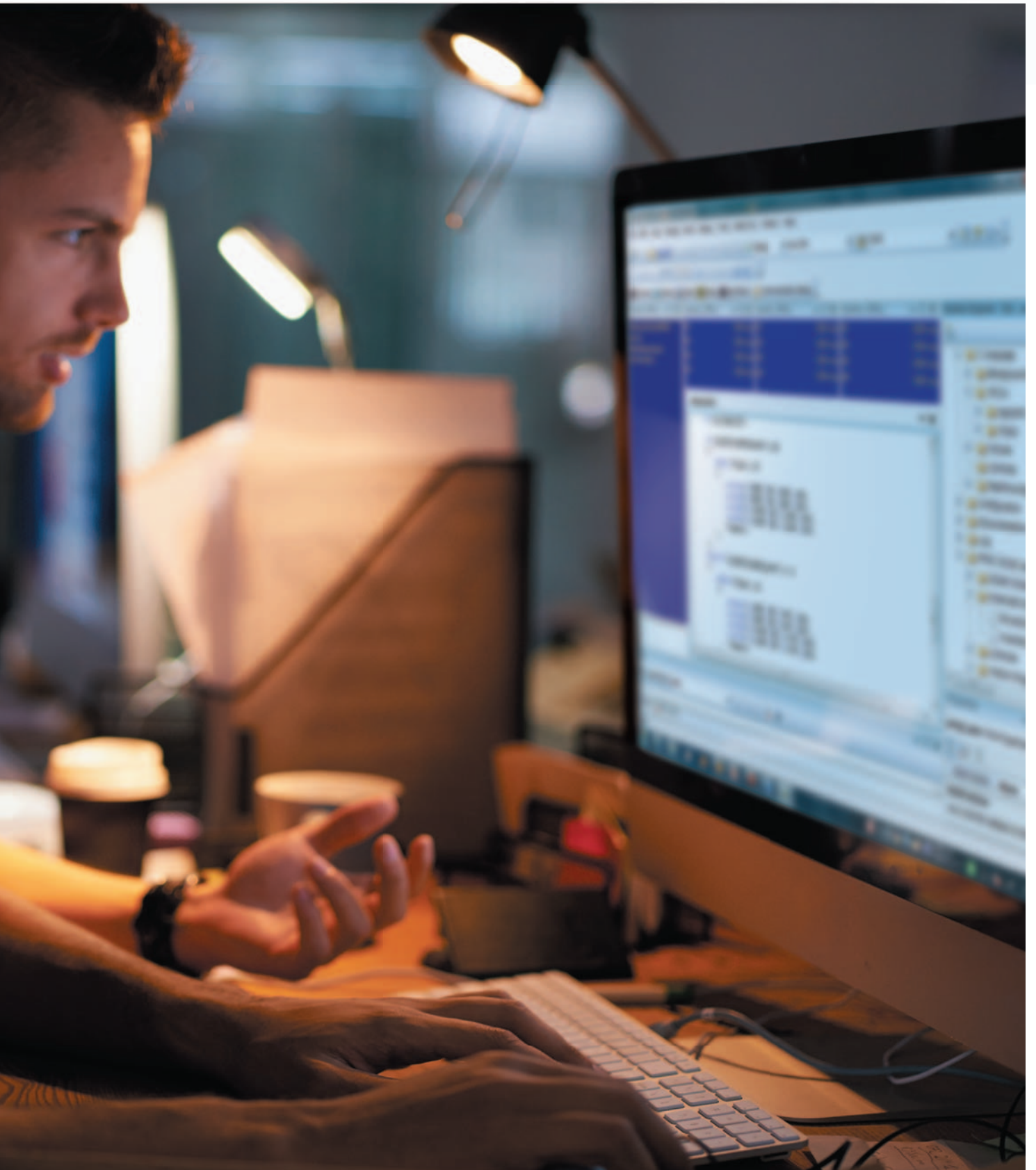

Control innovation through ultra-high-speed calculations

The Programmable Multi Axis Controller (PMAC) is a controller designed specially for high-precision multi-axis motion control applications. Delivering world-beating* output speeds to perform precise linear motor drive control and nanometer positioning, the PMAC is appreciated by manufacturers of semiconductor manufacturing equipment and other products employing leading-edge technologies.

* Refers to the motion control performance of 16.6 $\mu\text{s}/1$ axes or 50 $\mu\text{s}/8$ axes (Omron survey as of July 2016).

Ultra-high-speed, high-precision

The PMAC achieves full closed loop control of position, velocity, torque, and current every servo cycle time of 16.6 μs per axis (50 $\mu\text{s}/8$ axes). High-speed execution of motion programs, PLC programs, trajectory generation, and position compensation, improves positioning accuracy and velocity stability. The high-performance CPU centralizes the control of multiple axes to synchronize them precisely.

Flexible function development capability

The PMAC can be programmed in G-Code, ANSI C, or original programming language. This flexibility allows you to create your own control programs. You can use the servo algorithms that you designed using MATLAB®, add the program synchronized with PID control, and control your own mechanical system — Unlock your creativity.

Compatibility

You can configure a system to suit your application by connecting to both Omron devices and devices from other vendors. The PMAC can interface with virtually any type of motor including ultrasonic and voice coil motors, and can give position, velocity, and torque commands as well as commutation commands (two-phase analog commands and direct PWM commands) to the connected motors. Galvano scanner commands can also be put out. It provides various input and feedback interface capabilities to accept the A/B phase signals, 1Vp-p sine wave signals from linear encoders, and parallel binary signals from serial data interfaces and laser interferometers.

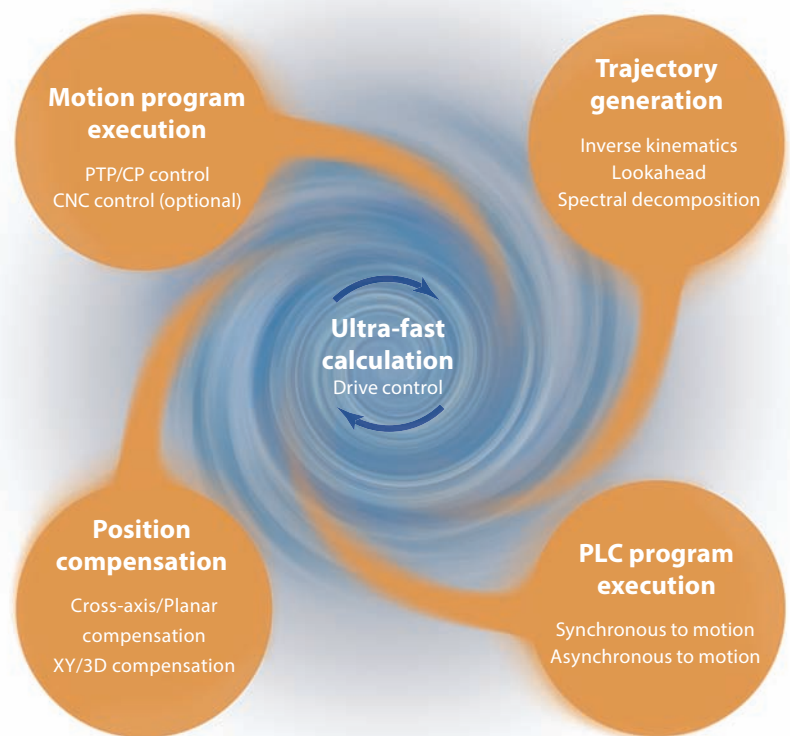

Innovative control applications

The PMAC allows you to develop advanced systems that integrate your own technologies. It is used for various applications from manufacturing sites to advanced academic studies.



Processing machines

High-speed, high-precision processing for electric discharge machines, water jet machines, laser processing machines, plasma processing machines, and ultra-precision machining systems

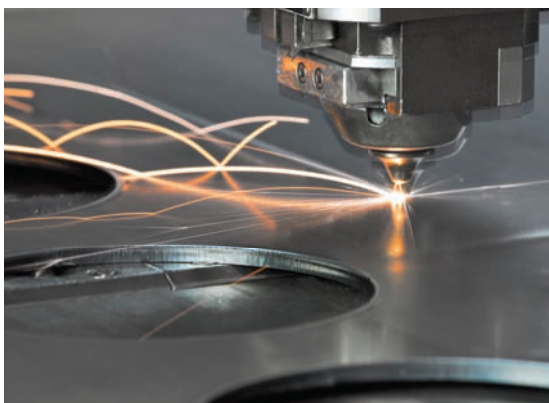

Semiconductor/FPD manufacturing/inspection machines

Extremely precise motion for electron beam exposure machines, linear coaters, sealant dispensers, and wafer inspection machines

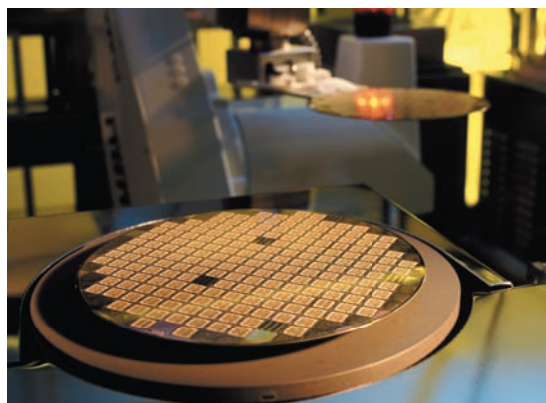

Robots

Complex mechanical control for machines using customized robots



Academic studies

Ultra-high-speed control functionality to control undulators and monochromators in synchrotron systems.



Versatile motion functions to create the best machine

Motor control

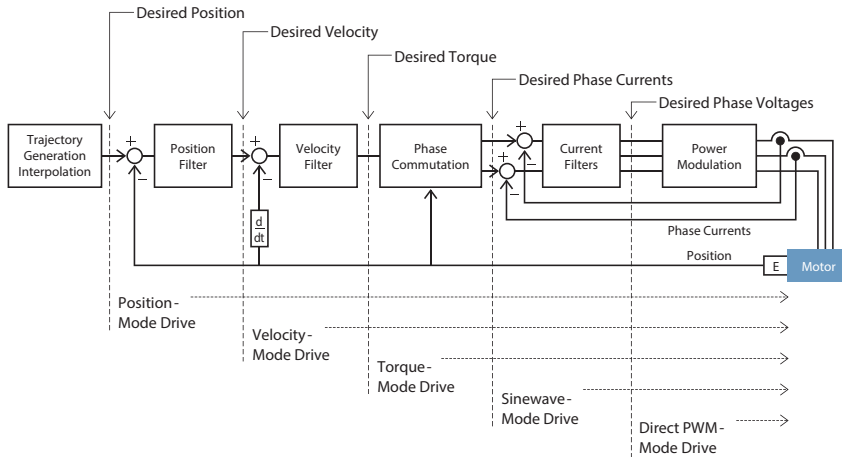

The PMAC has many modes for controlling motors: position-, velocity-, torque-, sinewave-, and direct PWM-mode drives. In addition to default servo algorithms, custom servo algorithms can be implemented. This enables motors to be fully synchronized even if many external devices are connected.

Automatically calculates position and velocity

Dynamic Lookahead

Algorithmically evaluates trajectories in advance of their execution. This optimized trajectory maximizes speed, acceleration and smoothness, reducing cycle time and improving path accuracy.

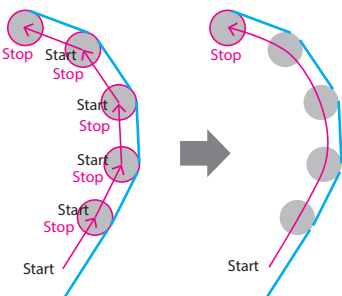

Positional Compensation

Table-based position compensation for imperfections in the mechanics enables more accurate motion.

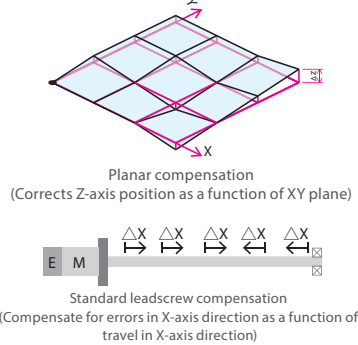

Forward / Inverse Kinematics

Write a kinematics calculation as a subroutine to control user-developed mechanical systems (e.g. robots). In addition to mechanical control, it can also convert the travel distance (velocity) of the laser scanning header into the laser pulse amount.

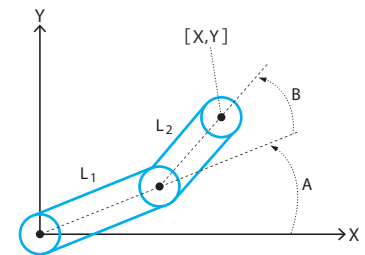

Precisely synchronizes axes

Motion Spectral Decomposition

A single trajectory is divided into separate components that the standard (e.g. XY stage) and fast-tool actuators (e.g. galvanometer actuator) execute in coordinated fashion.

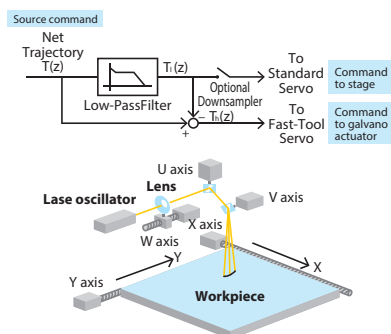

Ultra-fast Position-Compare

A hardware circuit creates an output pulse (response time: < 100 ns) when an exact encoder position is reached. Because it uses an actual position instead of a command, servo following errors do not affect the accuracy.

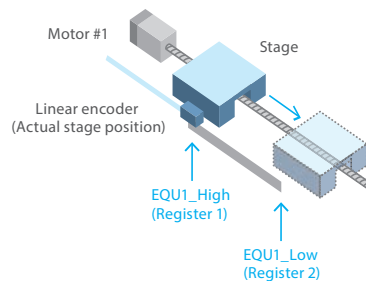

Cross-Coupled Gantry Control

Monitors in real time the positions of two gantry motors that have a tight mechanical linkage and corrects the skew between the motors to precisely synchronize the motion.

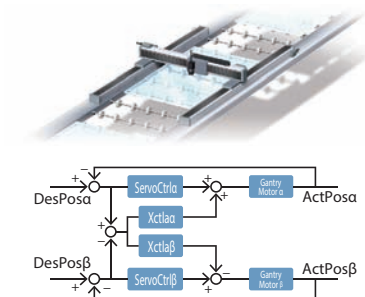

Creates motion profile

PVT Mode Contouring

Enables direct control over the trajectory profile created by combining trapezoidal and S-curve velocity profiles, achieving cycle time reduction and stability.

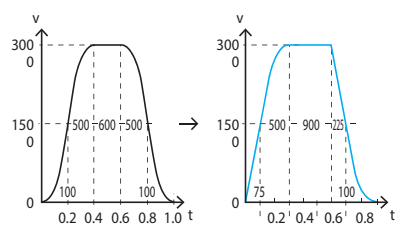

Spline Move Mode

Generates very smooth but complex profiles and contours. The time profiles are guaranteed to be continuous in position, velocity, and acceleration, even at move boundaries. Multi-dimensional paths are guaranteed continuous in position, direction, and curvature, even at move boundaries.

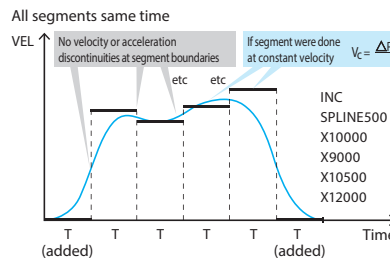

Move / Path Blending

Permits smooth transitions in centripetal acceleration when the radius/curvature changes, rather than the step change of unblended tangent moves. Linear, circle-, and PVT-mode moves can be blended.

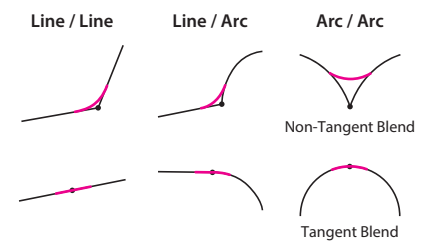

Suppresses disturbance

Torque Compensation

Provides velocity corrections by compensating for cyclic disturbances such as motor cogging torque.

Cogging torque

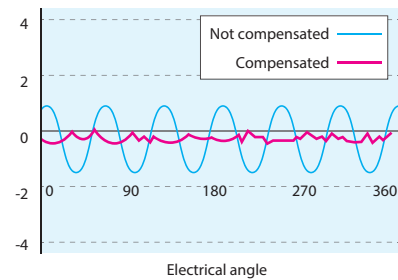

Trajectory Pre-Filter

Suppresses the occurrence of vibration by removing the resonant frequency with a trajectory pre-filter when sending a command.

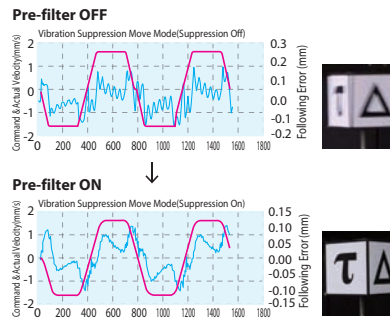

Adaptive Control

Automatically compensates for the load inertia changes to reproduce the intended motion.

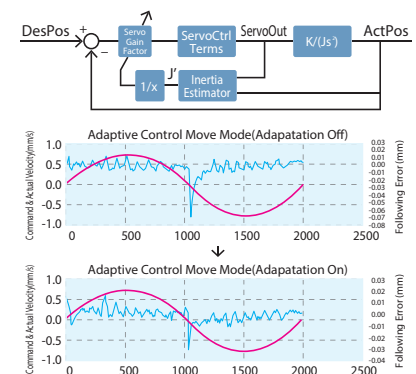

Executes motion program in synchronization with external input

Dual Feedback

Simultaneously uses velocity feedback from a servo and position feedback from a linear encoder or other device, providing extremely precise control (e.g. Bottom dead center control for high precision pressing machines).

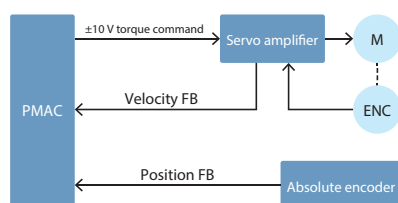

Cascaded Servo Loops

The output of one servo loop is used as an input to another servo loop, bringing the capabilities of both loops to bear on a single actuator. The coupling of the loops permits easy switching between control modes, e.g. from position control to load control when the target position is reached.

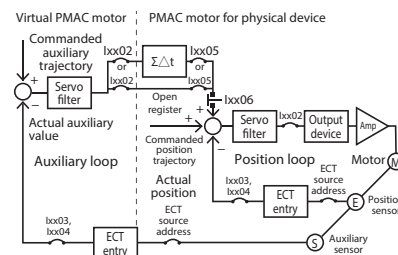

External Time Base Control

An electronic cam function can be created by executing a motion program, without using a cam table. The motion program is synchronized to an external axis, not to time. Multiple axes can be synchronized with workpiece feeding controlled by another controller, which is useful for thread cutting and pipe bending work.

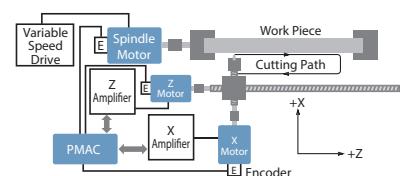

PMAC Series Product lineup

Saving space in machines

Compact Controller
CK3E

Saving space

Slim design of 28.6 mm saves space in machines and control panels

Cost effective

High-speed multi-axis control at an affordable cost - fastest cycle time of 250 μ s

Reduced wiring

One connection of servo drives, I/Os, and other devices via EtherCAT



CK3E-1□10

Main memory: 1 GB,
flash memory: 1 GB
1 x EtherCAT port,
1 x Ethernet port

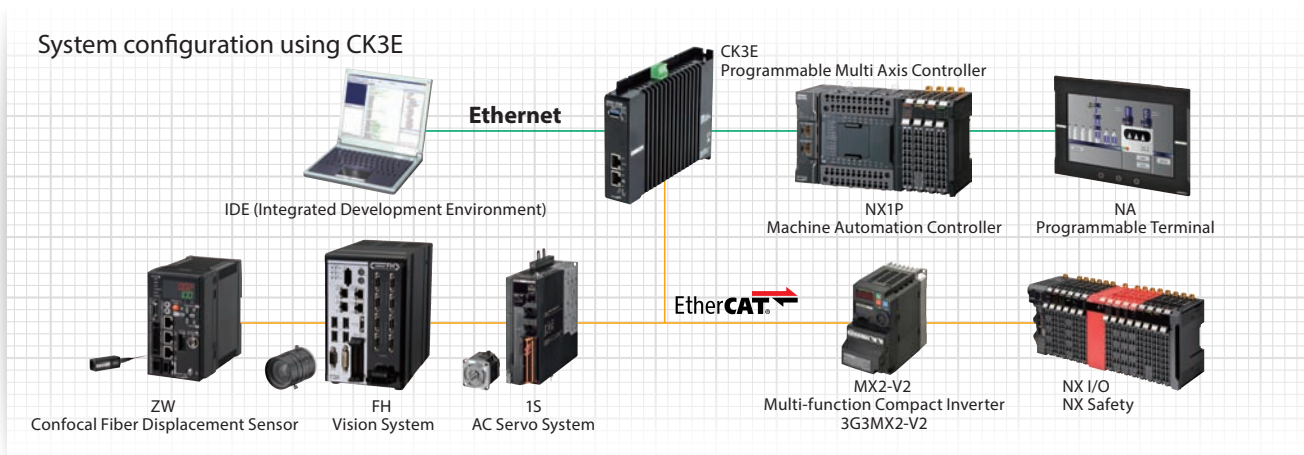

Powerful and scalable flagship controller

Modular Rack System Power UMAC

Customizable

Allows you to create a customer control system with exactly what you need for your application

Modular

Allows you to expand into multiple configurations for your control system and maintain commonality of hardware for each machine option

Flexible

Provides flexible connectivity and multiple communication methods, enabling you to take advantage of the most powerful and versatile machine control technology available



Power UMAC

1 GHz single-core or 1.2 GHz dual-core
Running on a Linux RTOS

Integrated multi-axis motion controller and amplifiers

Intelligent Amplifier Power Brick LV/AC

Integrated

A highly integrated package combining both the controller, amplifier and I/O

Convenient

Minimizes and simplifies your hardware and wiring in one system solution

Packaged

Integrated design allows for reduced cabinet space in a small, convenient package



Power Brick LV

4/8-axis
12-65 VDC (80 V option)



Power Brick AC

4/6/8-axis
240 VAC

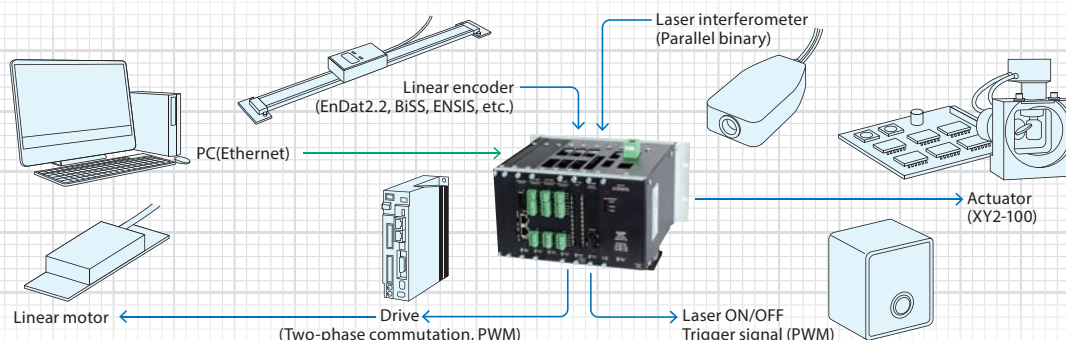

Note: Consult your Omron representative for details.

System configuration using Power UMAC: Laser marking machine



PMAC Series family

Specifications



Type		Compact Controller (CK3E)	Modular Rack System (Power UMAC)
Model		CK3E-1□10	3-4112A□U-□□□0-B00000 3-4241BEU-□□□-B00000
Appearance			
Motion control	Max. no. of controlled axes	8, 16, 32	256
	Motion control period	250 μs or more	16.6 μs or more
	Control method	Issuing control commands using EtherCAT communications	Available output accessories Analog (single-phase ±10 V) Pulse (pulse/direction) Two-phase analog (120° phase difference, ±10 V) Three-phase direct PWM
Interface	Ethernet port	●	●
	EtherCAT port	●	(Optional board)
	MACRO port	—	(Optional board)
	Analog I/O	—	(Optional board)
	Digital I/O	—	(Optional board)
	Feedback	—	Available feedback accessories ABZ phase Sine wave Parallel binary Serial encoders
Memory	RAM	1 GB	1 GB, 2 GB
	Flash	1 GB	1 GB, 4 GB, 8 GB, 16 GB
	Storage	—	—
Windows OS		—	—
Manufacturer		OMRON Corporation	Delta Tau Data Systems, Inc

Software

Name	Application
Power PMAC IDE	Computer software to be used in configuring the controller, creating user programs, and debugging the programs.
EC-Engineer	Computer software to be used in configuring and monitoring the EtherCAT network by using the controller as the EtherCAT master. Bundled with Power PMAC IDE.
Power PMAC NC	Power PMAC NC SDK Computer software to be used in controlling machine tools and other CNC machines with the controller and customizing HMI screens. Extension source codes used for customization are included.
	Power PMAC NC Runtime Computer software to be used in controlling machine tools and other CNC machines with the controller. Use this software when you do not customize the HMI screen.
Power PMAC Development Kit (PDK)	A collection of .Net Components and functions to be used in creating a .Net-based application program (HMI) that communicates to the controller.

Accessories for modular rack system (Power UMAC)

Digital I/O board		
ACC-65E	24 inputs/24 outputs, self-protected (overcurrent etc.) 12-24 VDC/PNP type/isolated Terminal block	48 outputs, self-protected (overcurrent etc.) 12-24 VDC/PNP type/isolated Terminal block
	Option D-Sub 15 pin (female)	ACC-67E
ACC-14E	48-bit input/output board 5 VDC	Option D-Sub 15 pin (female)
	48 inputs, sourcing, self-protected (overvoltage by Zener diode) 12-24 VDC/isolated Terminal block	ACC-68E
ACC-66E	Option D-Sub 15 pin (female)	Option D-Sub 15 pin (female)

		Intelligent Amplifier (Power Brick LV/AC)	
		Low voltage type (LV)	High voltage type (AC)
		PBL□	PBA□
			
		4, 8	4, 6, 8
		16.6 μs or more	
		Built-in motor amplifiers	Built-in motor amplifiers
		●	
		● (Option)	
		● (Option)	
		● (Option)	
		● (Option)	
		Available feedback options ABZ phase Sine wave Parallel binary Serial encoders	
		1 GB, 2 GB	
		1 GB, 4 GB, 8 GB	
		—	
		—	
		Delta Tau Data Systems, Inc	

Analog I/O board	Special field bus communication board	Axis interface board	
ACC-59E3	ACC-72EX	ACC-24E3	2 or 4-axis digital amplifier (PWM) interface TB connector or DB-15 connector
		ACC-24E3A	2 or 4-axis analog amplifier (±10 V) interface TB connector or DB-15 connector
		ACC-24E3 Mezzanine Board	Digital feedback
			Analog feedback
		Special encoder feedback	
		ACC-51E	2-axis 4096x high-resolution analog encoder interpolator board
		ACC-84E	UMAC universal serial encoder interface
MACRO board			
		ACC-5E3	For Power Series
Power supply			
		ACC-E1	115/230 VAC input UMAC power supply
		ACC-F1	24 VDC input UMAC power supply

Windows and Visual Studio are either registered trademarks or trademarks of Microsoft Corporation in the United States and/or other countries.
EtherCAT® is registered trademark and patented technology, licensed by Beckhoff Automation GmbH, Germany.
Other company names and product names in this document are the trademarks or registered trademarks of their respective companies.
The product photographs and figures that are used in this catalog may vary somewhat from the actual products.
Microsoft product screen shot(s) reprinted with permission from Microsoft Corporation.
PMAC is an abbreviation for Programmable Multi Axis Controller.

Note: Do not use this document to operate the Unit.

OMRON Corporation Industrial Automation Company

Kyoto, JAPAN

Contact : www.ia.omron.com

Regional Headquarters

OMRON EUROPE B.V.

Wegalaan 67-69, 2132 JD Hoofddorp
The Netherlands
Tel: (31) 2356-81-300 Fax: (31) 2356-81-388

OMRON ASIA PACIFIC PTE. LTD.

438B Alexandra Road, #08-01/02 Alexandra
Technopark, Singapore 119968
Tel: (65) 6835-3011 Fax: (65) 6835-3011

OMRON ELECTRONICS LLC

2895 Greenspoint Parkway, Suite 200
Hoffman Estates, IL 60169 U.S.A.
Tel: (1) 847-843-7900 Fax: (1) 847-843-7787

OMRON (CHINA) CO., LTD.

Room 2211, Bank of China Tower,
200 Yin Cheng Zhong Road,
PuDong New Area, Shanghai, 200120, China
Tel: (86) 21-6023-0333 Fax: (86) 21-5037-2388

Authorized Distributor:

©OMRON Corporation 2017-2024 All Rights Reserved.
In the interest of product improvement,
specifications are subject to change without notice.

CSM_2_6

Cat. No. R192-E1-06 1024 (0318)