

GigE Vision

Monochrome / Color CMOS PoE Camera

STC-MBA503POE (5M / Monochrome)

STC-MCA503POE (5M / Color)

Product Specifications and User's Guide

OMRON SENTECH CO., LTD.

Table of Contents

1	Product Precautions	8
2	Warranty.....	8
3	Software Licensing	9
3.1	LWIP TCP/IP Licensing	9
4	Overview	10
4.1	Features	10
4.2	Product Name Naming Method	10
5	Specifications.....	11
5.1	Electronic Specifications.....	11
5.2	Spectral Sensitivity Characteristics	13
5.2.1	STC-MBA503POE.....	13
5.2.2	STC-MCA503POE (without IR Cut Filter).....	13
5.2.1	IR Cut Filter (STC-MCA503POE).....	14
5.3	Mechanical Specifications.....	14
5.4	Environmental Specifications	15
6	Connector Specifications	16
6.1	RJ45 Connector.....	16
6.2	Power and Control Signal Connector.....	17
6.2.1	Opto-isolated input.....	20
6.2.2	Opto-isolated output.....	20
6.2.3	Open Collector GPIO	21
6.2.4	Input and Output Signal Timing (Hardware Trigger).....	22
6.2.5	Input and Output Signal Timing (Software Trigger).....	23
6.2.6	External Hardware Trigger Input Delay.....	24
6.2.6.1	External Trigger Signal Delay (Positive polarity trigger signal).....	24
6.2.6.2	External Trigger Signal Delay (Negative polarity trigger signal)	24
6.2.6.3	Measured External Trigger Signal Delay through Opt-Isolated Port (Line 0).....	25
6.2.6.4	Measured External Trigger Signal Delay through Open Collector GPIO Port (Line 2)	26

7	Dimensions	27
7.1	STC-MBA503POE	27
7.2	STC-MCA503POE	28
8	Sensor Information	29
8.1	Pixel Transferring Image.....	29
9	Camera Operational Modes	30
9.1	Normal Mode (Rolling shutter).....	30
9.2	Pulse width trigger mode.....	31
9.2.1	Timing (when using rolling shutter)	31
9.2.2	Exposure Timing with Positive Polarity Trigger Signal.....	32
9.2.3	Exposure Timing with Negative Polarity Trigger Signal.....	33
9.3	Edge Preset Trigger Mode	34
9.3.1	Timing (When using rolling shutter).....	34
9.3.2	Exposure Timing with Positive Polarity Trigger Signal.....	35
9.3.3	Exposure Timing with the Negative Polarity Trigger signal.....	35
9.4	Edge Preset Trigger Mode (Trigger input while image is out)	36
9.4.1	Timing.....	36
10	Camera Functions	37
10.1	Save and load the camera settings.....	37
10.1.1	Saving Camera Settings.....	37
10.1.2	Loading Camera Settings.....	38
10.1.3	Loading Camera Settings when Camera Power is on	38
10.1.4	Camera Settings Initialization	38
10.2	Frame rate	39
10.3	Gain	39
10.3.1	Analog Gain	39
10.3.2	Digital Gain.....	39
10.4	Exposure Time.....	40
10.5	Black Level.....	40
10.6	ALC (Auto Light Control)	41

10.6.1	ALC control method	42
10.6.2	AGC (Auto Gain Control).....	43
10.6.3	Auto shutter	44
10.6.4	ALC settings procedure	44
10.7	White balance (Only available for color camera).....	45
10.7.1	White balance control methods.....	45
10.7.2	White balance control method selection.....	45
10.7.3	White balance calculate region setting	46
10.8	Gamma correction.....	47
10.9	ROI (Region of Interest)	47
10.10	Pixel Format.....	48
10.11	Binning.....	49
10.12	Decimation	50
10.13	Trigger	51
10.13.1	Trigger signal processing procedure	51
10.14	Image Flip.....	52
10.15	LUT Control.....	52
10.16	Defective pixel correction.....	53
10.17	Counter And Timer Control	54
10.18	Event Control.....	55
10.19	Chunk Control	56
10.20	Action Control	56
10.21	IEEE1588	57
11	GenICam command.....	59
11.1	DeviceControl	59
11.2	ImageFormatControl	61
11.3	AcquisitionControl	62
11.4	AnalogControl	63

11.5	LUTControl.....	64
11.6	DigitalIOControl.....	65
11.7	LogicBlockControl	65
11.8	SoftwareSignalControl.....	65
11.9	CounterAndTimerControl	66
11.10	EventControl.....	67
11.11	UserSetControl	67
11.12	ChunkDataControl.....	68
11.13	ActionControl	68
11.14	File AccessControl	69
11.15	TestControl	69
11.16	TransportLayerControl	70
12	Revision History.....	72

Precautions for safe use

Please read carefully this "Precautions for safe use" before use the camera. Then the camera uses correctly with agreeing with below notes.

In this "Precautions for safe use", notes divides into "Warning" and "Caution" to use the camera safety and prevent to harm and damage.

Warning	This shows, assumption for possibility of serious accident leading death or serious injury if ignore this note and camera uses incorrectly.
Caution	This shows, assumption for possibility of bear the damage or physical damage if ignore this note and camera uses incorrectly.

About Graphic symbols



This symbol shows general prohibition.







This symbol shows completion or instruction.

[Environment / condition]









Warning	
	<p>Do not use flammable or explosiveness atmospheres. This will cause of personal injury or fire.</p>
	<p>Do not use for "safety for human body" related usage. This camera is designed for use "do not harm human body immediately" if by any chance the camera has malfunction.</p>
Caution	
	<p>Use and store under specified environmental conditions (Vibration, shock, temperature, humidity) in the specifications for this camera. This will cause of fire or damage the camera.</p>

[Installation and cable wiring]



Warning	
	<p>Do not use with out of power voltage range that is specified in the specifications for this camera. This will cause of fire, electrification or malfunction.</p>
	<p>Do not wrong wiring. This will cause of fire or malfunction.</p>

 Caution	
 The camera housing and 0 V line of camera inside circuit are isolated. There is a risk of short circuit between camera inside circuit and frame ground through other devices. This will cause of malfunction.	 It is necessary to wiring and mounting that is specified in the specifications for this camera. This will cause of fire or malfunction.
 It is necessary to wiring with turn off the camera. This will cause of electrification or malfunction.	 It is necessary to mounting the camera without stress for the cable. This will case of electrification or fire.

[Usage instruction]

 Warning	
 Do not touch the terminal and PCB board While turn on the camera. This will cause of electrification or accident caused by malfunction.	 Do not put combustibles near the camera. This will cause of fire.
 Do not use without usage that is specified in the specifications for this camera. This will cause of personal injury or malfunction.	 Do not push metals including screw driver into radiation holes. This will cause of electrification or malfunction.
 Do not touch the camera housing while or after using the camera. There is a risk of get burned.	
 Caution	
 Do not push contamination into opening of the camera. This will cause of electrification or malfunction.	 Do not block the radiation holes. This will cause of fire due to increase the camera inside temperature.

[Maintenance]

 Caution	
 Do not disassemble or repair the camera. This will cause of fire, electrification or malfunction.	 It is turn off the camera when maintaining or inspecting the camera. This will cause of electrification.

[Disposal]

 Caution	
 It is necessary to dispose as industrial waste.	

1 Product Precautions

- Do not give shock to the camera.
- Do not haul or damage the camera cable.
- Do not wrap the camera with any material while using the camera. This will cause the internal camera temperature to increase.
- When the camera moving or using the place that temperature difference is extreme, countermeasure for dew condensation (heat removal / cold removal) is necessary.
- While the camera is not using, keep the lens cap on the camera to prevent dust or contamination from getting in the sensor or filter and scratching or damaging it.
Do not keep the camera under the following conditions.
 - In wet, moist, high humidity or dusty place
 - Under direct sunlight
 - In extreme high or low temperature place
 - Near an object that releases a strong magnetic or electric field
 - Place with strong vibrations
- Apply the power that satisfies the specified in specifications for the camera.
- The defective pixels may appear due to the sensor characteristics.
- Use below recommend materials (or equivalent materials) to clean the surface of glass.
 - Air dust: Non Freon air duster (NAKABAYASHI Co., LTD.)
 - Alcohol: Propan-2-ol (SAN'EI KAKO Co., LTD.)
 - Non-woven: nikowipe clean room (NKB)
- Use a soft cloth to clean the camera.

2 Warranty

■ Warranty period

One year after delivery (However, the camera had malfunction with camera uses correctly)

In below case for a fee even within warranty period.

- The malfunction caused by incorrect usage, incorrect modify or repair.
- The malfunction caused by external shock including the camera dropping after delivery the camera.
- The malfunction caused by fire, earthquake, flood disaster, thunderbolt struck, other natural disaster or wrong voltage.

■ Warranty coverage

Exchange or repair the malfunction camera if the malfunction is occurred by our responsibility.

“Warranty” mean is warranty for the delivered camera itself. Please accept the induction damage by the camera malfunction is not included.

3 Software Licensing

3.1 LWIP TCP/IP Licensing

The software in this camera includes LWIP TCP/IP implementation.
The copyright information is

Copyright (c) 2001-2004 Swedish Institute of Computer Science.
All rights reserved.

Redistribution and use in source and binary forms, with or without modification, are permitted provided that the following conditions are met:

1. Redistributions of source code must retain the above copyright notice, this list of conditions and the following disclaimer.
2. Redistributions in binary form must reproduce the above copyright notice, this list of conditions and the following disclaimer in the documentation and/or other materials provided with the distribution.
3. The name of the author may not be used to endorse or promote products derived from this software without specific prior written permission.

THIS SOFTWARE IS PROVIDED BY THE AUTHOR "AS IS AND ANY EXPRESS OR IMPLIED WARRANTIES, INCLUDING, BUT NOT LIMITED TO, THE IMPLIED WARRANTIES OF MERCHANTABILITY AND FITNESS FOR A PARTICULAR PURPOSE ARE DISCLAIMED. IN NO EVENT SHALL THE AUTHOR BE LIABLE FOR ANY DIRECT, INDIRECT, INCIDENTAL, SPECIAL, EXEMPLARY, OR CONSEQUENTIAL DAMAGES (INCLUDING, BUT NOT LIMITED TO, PROCUREMENT OF SUBSTITUTE GOODS OR SERVICES; LOSS OF USE, DATA, OR PROFITS; OR BUSINESS INTERRUPTION) HOWEVER CAUSED AND ON ANY THEORY OF LIABILITY, WHETHER IN CONTRACT, STRICT LIABILITY, OR TORT (INCLUDING NEGLIGENCE OR OTHERWISE) ARISING IN ANY WAY OUT OF THE USE OF THIS SOFTWARE, EVEN IF ADVISED OF THE POSSIBILITY OF SUCH DAMAGE.

4 Overview

This document describes the specification of the following cameras:

STC-MBA503POE / STC-MCA503POE

4.1 Features

- GigE Interface
- Support PoE (Power over Ethernet)
- Small robust camera housing
- Maximum frame rate (Full resolution): 14 fps @ 5M 8bits
- CMOS (Global Reset Shutter / Rolling Shutter)
- Up to 2,048 Defective Pixel Correction (Default: ON)
- 8bits, 10bits, 12bits output

4.2 Product Name Naming Method

STC-MxA503POE

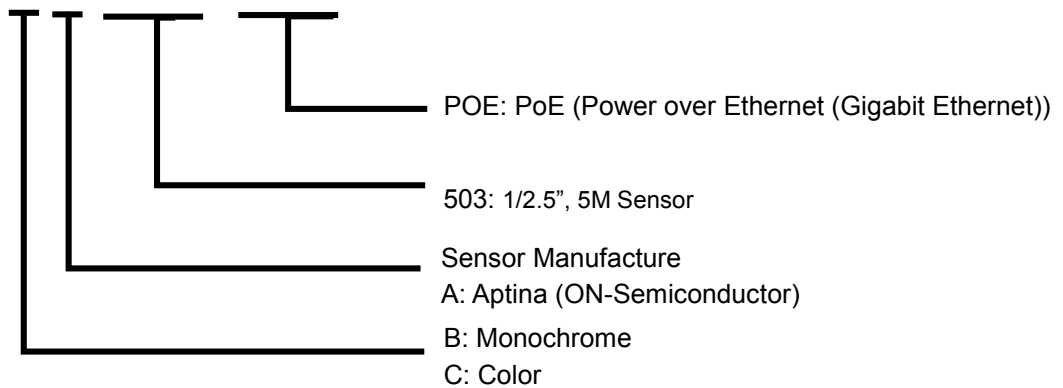

5 Specifications

5.1 Electronic Specifications

Product		STC-MBA503POE	STC-MCA503POE
Image Sensor		1/2.5" 5M Progressive Monochrome CMOS (ON-Semiconductor: MT9P031)	1/2.5" 5M Progressive Color CMOS (ON-Semiconductor: MT9P031)
Shutter Type		Global Rest / Rolling Shutter	
Active Picture Elements		2,592 (H) x 1,944 (V)	
Cell Size		2.2 (H) x 2.2 (V) μm	
Scanning Mode		Full scanning (Full resolution) / ROI	
Frame rate (at full scanning)	Rolling shutter, free run	8bits: 14 fps / 10bits: 10.9 fps / 10bits Packed: 14 fps / 12bits: 10.9 fps / 12bits Packed: 14 fps / RGB8: 7.2 fps Maximum frame rate: 2,499 fps @ 2 lines (8bits)	
	Rolling shutter, free run / Global reset	8bits / 10bits / 10bitsPacked / 12bits / 12bitsPacked / RGB8: 4.7 fps	
ADC bit depth		12bits	
Image Output Format (*1)		Mono8 / Mono10 / Mono10Packed / Mono12 / Mono12Packed	Mono8 / Mono10 / Mono10Packed / Mono12 / Mono12Packed / BayerRG8 / BayerRG10 / BayerRG10Packed / BayerRG12 / BayerRG12Packed / RGB8
Noise Level	8bits output	Less than 3.7 digits (Gain 0 dB)	
	10bits / 10bits Packed output	Less than 14.8 digits (Gain 0 dB)	
	12bits / 12bits Packed output	Less than 59.2 digits (Gain 0 dB)	
Sensitivity (*2)		800 Lux	2,000 Lux
Exposure Time		32 $\mu\text{seconds}$ to 16.777 seconds (Default: 107,488 $\mu\text{seconds}$)	
Gain	Analog Gain	x1 to x7.875 (Default: x1)	
	Digital Gain	x1 to x5 (Default: x1)	
ROI		Horizontal: 8 to 2,592 pixels, Vertical: 2 to 1,944 lines (Default: 2,592 x 1,944) Adjustable steps for size: 8 pixels in horizontal direction and 2 lines in vertical direction Adjustable steps for offset: 8 pixels in horizontal direction and 2 lines in vertical direction	
Gamma		Gamma 0.1 to 4.0 (Default: 1.0)	
Binning		Horizontal: 1/2, 1/4, Off / Vertical: 1/2, 1/4, Off	
Decimation Function		Horizontal: 1/2, 1/3, 1/4, 1/5, 1/6, 1/7, Off / Vertical: 1/2, 1/3, 1/4, 1/5, 1/6, 1/7, Off	
Image Flip		Horizontal / Vertical / Horizontal and vertical / Off	
Defective Pixel Correction		Up to 2,048 points (Default: On)	
Auto Image Control	Auto Exposure	Support (Default: OFF)	
	Auto Gain	Support (Default: OFF)	
	Auto White Balance	N/A	Support
Operational Mode		Edge preset trigger / Pulse width trigger / Free run	
Interface		PoE: IEEE802.3af CLASS2 (1000BASE-T)	
Protocol		GigE Vision 2.1 and GenICam SFNC 2.4, IEEE1588 (PTP)	
I/O		One opto-isolated input, one opto-isolated output and one open collector GPIO (Input or output)	
Power	Input Voltage (*3)	+10.8 to +26.4 Vdc External power (via 6 pin connector) / Power Over Ethernet (IEEE802.3af)	
	Consumption	+12 V / +24 V: 3.0 W, PoE: 3.4 W	

Default: **Bold**

Precautions

(*1) The Bayer color image format changes when selecting flip image function.
Bayer color image format for flip image is off Is listed on this specification.

(*2) The sensitivity is measuring the luminance when white level achieved 100 % in below conditions.

Camera Setting		Environment	
Parameter	Setting	Parameter	Setting
Gain Up	0 dB	Light Source	Light Box (White)
AGC	Off	Color temperature	5,100K
White Balance	Optimum	Lens	
Electrical Shutter	1/30 seconds	F on Lens	F5.6
Black Level	Optimum	Target Luminance	IM-600 (Topcon)
Gamma	Factory Setting		

(*3) The camera operates with external power when power supplying by external power supply and PoE to camera at same time.

5.2 Spectral Sensitivity Characteristics

5.2.1 STC-MBA503POE

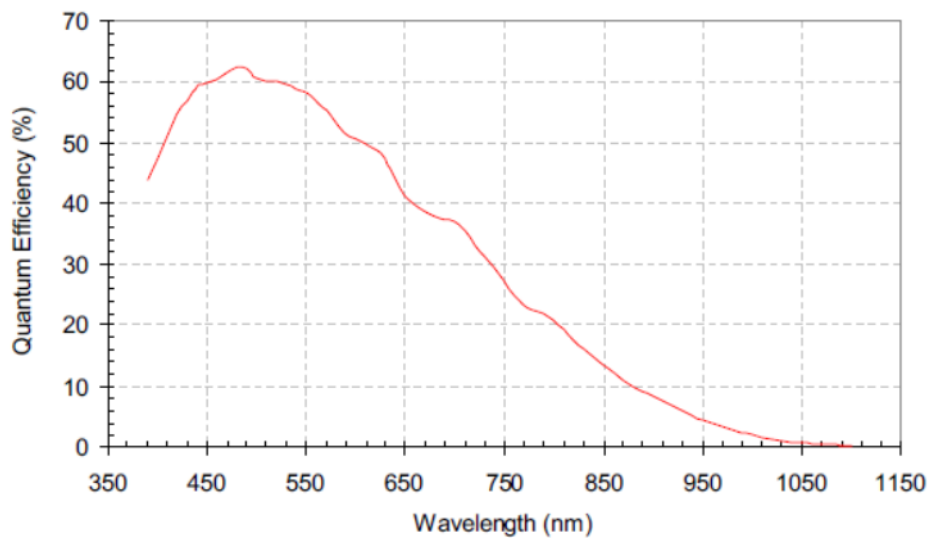

5.2.2 STC-MCA503POE (without IR Cut Filter)

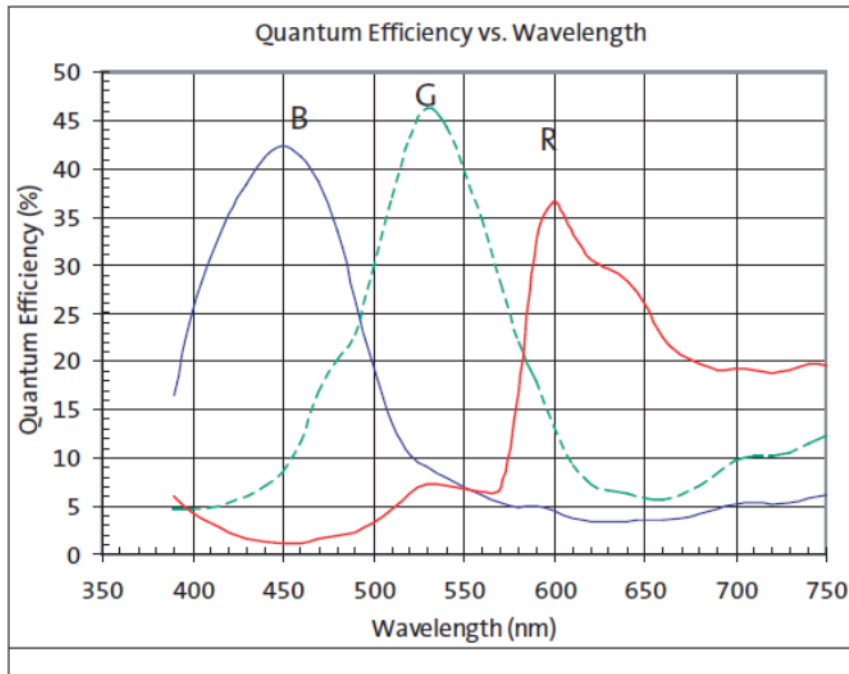

5.2.1 IR Cut Filter (STC-MCA503POE)

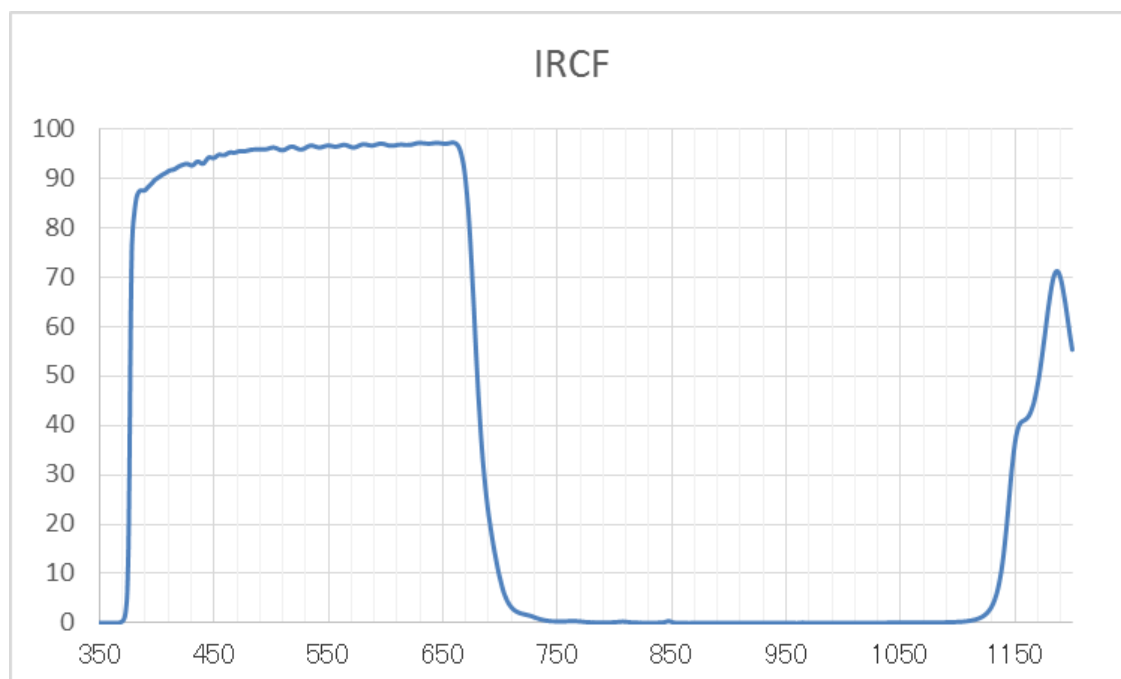

5.3 Mechanical Specifications

Model Number	STC-MBA503POE	STC-MCA503POE
Dimensions	29 (W) x 29 (H) x 53 (D) mm (*1)	
Optical Filter	No Optical Filter	IR Cut Filter
Optical Center Accuracy	Positional accuracy in Horizontal and Vertical directions: +/- 0.3 mm Rotational accuracy of Horizontal and Vertical: +/- 1.5 deg.	
Material	Aluminum Alloy (AC)	
Lens Mount	C mount	
Interface Connectors	Ethernet connector: RJ45 connector Power- I/O connector: HR10A-7R-6PB (Hirose) or equivalent	
Camera Mounting	Six M3 screw holes (Two on top, four on bottom plate)	
Weight	Approximately 62 g	

(*1) Excluding the connectors

5.4 Environmental Specifications

Model Number		STC-MBA503POE	STC-MCA503POE
Operational Temperature / Humidity	Minimum	Environmental Temperature: 0 deg. C, Environmental Humidity: 0 to 85 %RH (No condensation)	
	Maximum	Environmental Temperature: +36 deg. C or Camera housing temperature (top plate) shall not exceed +57 deg. C (*1) Environmental Humidity: 0 to 85 %RH (No condensation)	
Storage Temperature / Humidity		Environmental Temperature: -20 to +70 deg. C, Environmental Humidity: 0 to 85 %RH (No condensation)	
Vibration		20 Hz to 200 Hz to 20 Hz (5 min. / cycle), acceleration 10 G, XYZ 3 directions, 30 min. each	
Shock		Acceleration 38 G, half amplitude 6 ms, XYZ 3 directions, 3 times each	
Standard Compliancy		EMS: EN61000-6-2, EMI: EN55011	
RoHS		RoHS Compliance	

(*1) Please insure the camera is installed with the appropriate heat dissipation. If camera has a mounted lens and a tripod with an aluminum plate, this could decrease the camera housing temperature for heat dissipation. When the internal temperature sensor on the camera shows less than 66 deg. C, the camera housing temperature (top plate) will be less than 57 deg. C.

Taking these steps will maintain the heat rating of the electronic components of the camera.

Upper side of camera

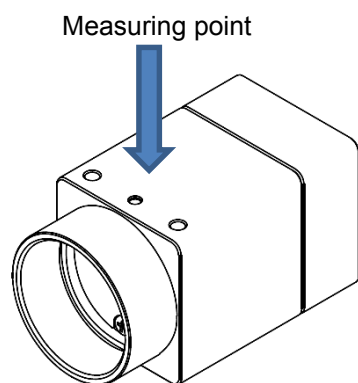

6 Connector Specifications

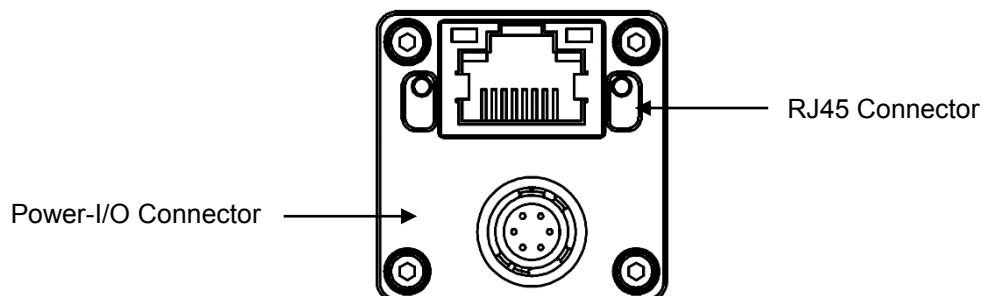

6.1 RJ45 Connector

This product is PoE compliant.

Please supply power (+10.8 to +26.4 Vdc) through the power-I/O connector when using non-PoE-compliant NIC.

Pin Assignment

Pin No.	Signal Name
1	TA+
2	TA-
3	TB+
4	TC+
5	TC-
6	TB-
7	TD+
8	TD-

LED

Green LED	Yellow LED	Status
Green Light ON	Yellow Light OFF	Power ON (1GB NIC)
Green Light OFF	Yellow Light OFF	Power ON (100MB NIC)
Green Light ON	Yellow Light Blinking	1 GB Transferring
Green Light OFF	Yellow Light Blinking	100 MB Transferring

Yellow LED Green LED

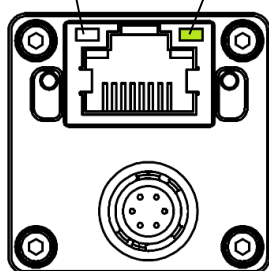

Camera is powered-on

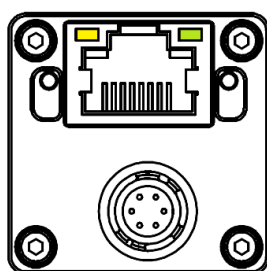

Green light: ON
Yellow light: Blinking
1 GB Transferring

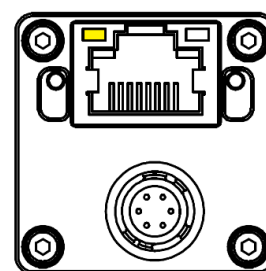

Green light: OFF
Yellow light: Blinking
100 MB Transferring

Please use a 1GB supported NIC, Network Switcher and Ethernet cable.

Check the setting of NIC and Network Switcher being used is "1GB transferring".

6.2 Power and Control Signal Connector

HR10A-7R-6PB (Hirose) or equivalent

This connector is for the power supply and input / output signals.

The power from this connector is priority power for camera when power supplies through this connector and PoE at same time.

Please use HR10A-7P-6S (Hirose) or equivalent for cable.

Pin assignment

Pin No.	Signal Name	IN / OUT	Voltage
1	POWER IN	IN	+10.8 to +26.4 Vdc
2	Opto-isolated in (Line0)	IN	Low: Smaller than +1.0 V High: +3.0 to +26.4 V * Potential difference between TRG_in and Opt. Isolated Common
3	Open Collector GPIO (Line2)	IN / OUT	+3.0 to +26.4 V / Open Collector
4	Opto-isolated out (Line1)	OUT	Open Collector
5	Opto-isolated Common	IN	
6	GND	IN	0 V

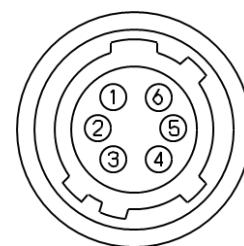

Configuration of Line2 (Pin No.3) and Line1 (Pin No.4)

Output signal can be assign by GenICam command.

GenICam
1) Frame Trigger Wait (Default for all output)
2) Frame Trigger Internal
3) Exposure Active
4) Acquisition Trigger Wait
5) Acquisition Trigger Internal
6) Sensor Read Out
7) Debounced Line 0
8) Debounced Line 2
9) User Output 1
10) User Output 2
11) Timer 0 Active
12) Software Signal 0
13) Software Signal 1
14) Logic Block 0
15) Pulse Per Second
16) Flash Window

- 1) Frame Trigger Wait
The condition of camera operation with trigger signal can be check.
“LOW” state of signal is out between “start exposing” to “image out”.
- 2) Frame Trigger Internal
The input trigger signal with the trigger delay (camera internal process delay).
- 3) Exposure Active
While camera exposing, “HIGH” state of signal is out. The signal state will be “LOW” after finish exposing.
- 4) Acquisition Trigger Wait
While image transferring from camera to PC, “Low” state of signal is out. The signal state will be “High” after finish image transferring.
- 5) Acquisition Trigger Internal
The image transferring starts signal is out.
- 6) Sensor Read Out
FVAL (Frame valid, HIGH state) signal is out.
- 7) Debounced Line0
Debounced Line0 signal is out.
- 8) Debounced Line2
Debounced Line2 signal is out.
- 9) User Output 1 (User Output signal through Line 1)
Selected “HIGH” or “LOW” state of signal is out.
- 10) User Output 2 (User Output signal through Line 2)
Selected “HIGH” or “LOW” state of signal is out.
- 11) Timer 0 Active
Selected signal at “Timer Counter” is out.
When signal synchronizing with “Exposure Active” signal, signal can use for strobe control.
- 12) Software Signal 0
Selected signal for “Software Signal 0” at “Software Signal Control” is out.
- 13) Software Signal 1
Selected signal for “Software Signal 1” at “Software Signal Control” is out.
- 14) Logic Block 0
“Logic Block 0” signal is out.
- 15) Pulse Per Second
“Pulse / second” signal (50% Duty, 1 Hz interval) is out.

16) Flash Window

The external light source control signal is out.

This signal can be used to set active time of light source for rolling shutter to acquire acceptable image.

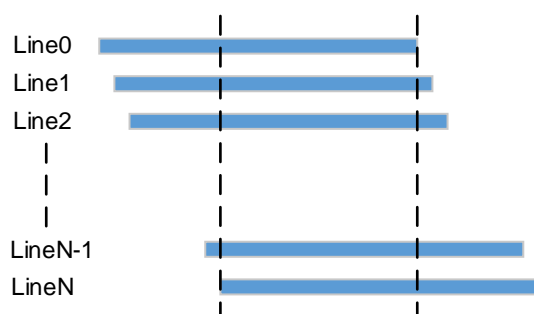

Rolling shutter

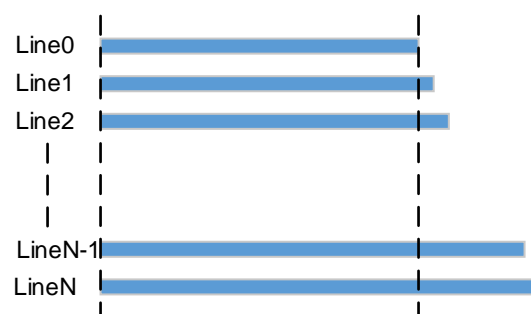

Global Reset shutter

6.2.1 Opto-isolated input

The camera has current limiting circuit on camera. The current limiting resistor does not necessary.

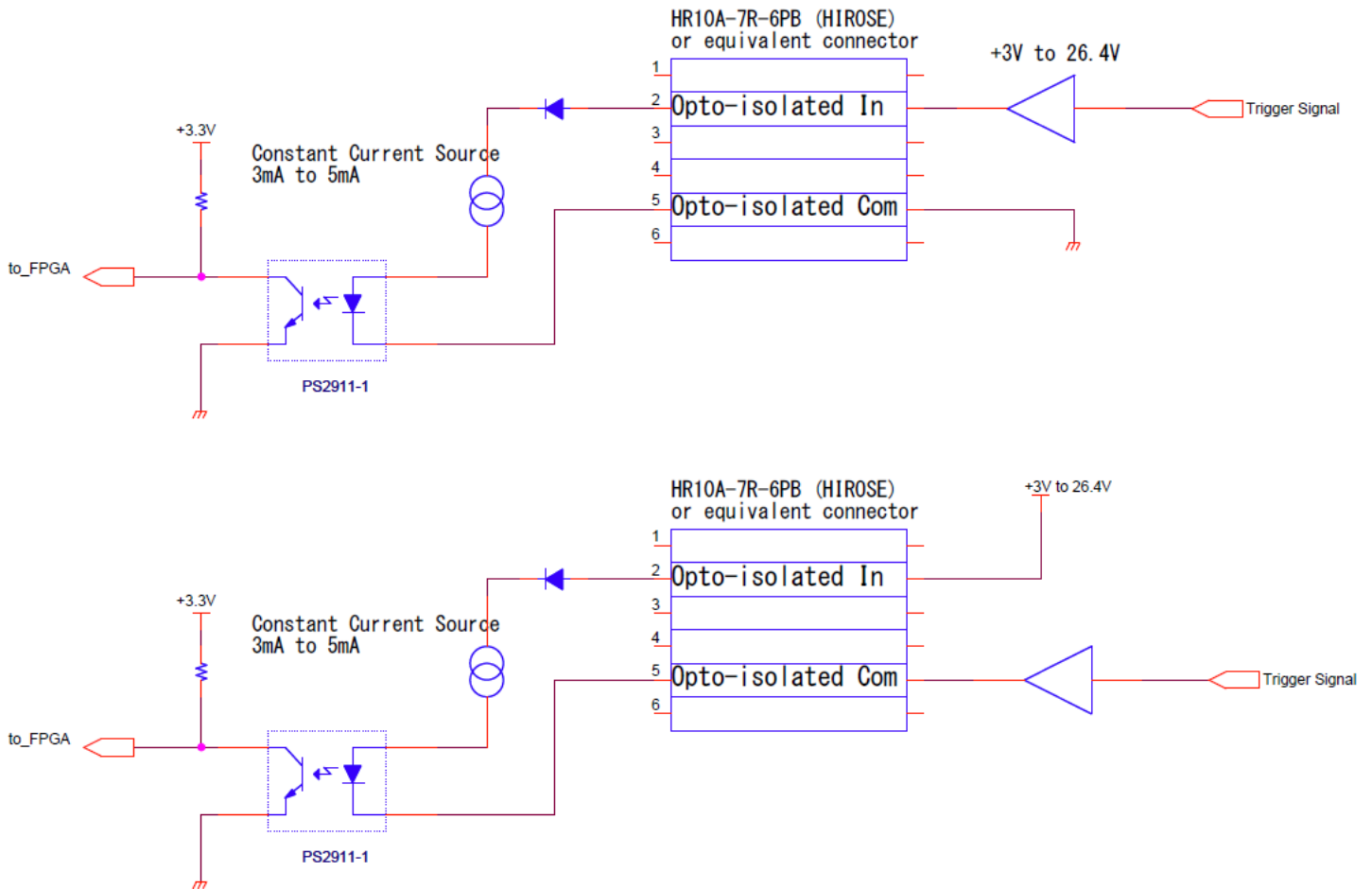

6.2.2 Opto-isolated output

It is necessary to have current limiting resistor at outside of camera, to keep less than 50 mA.

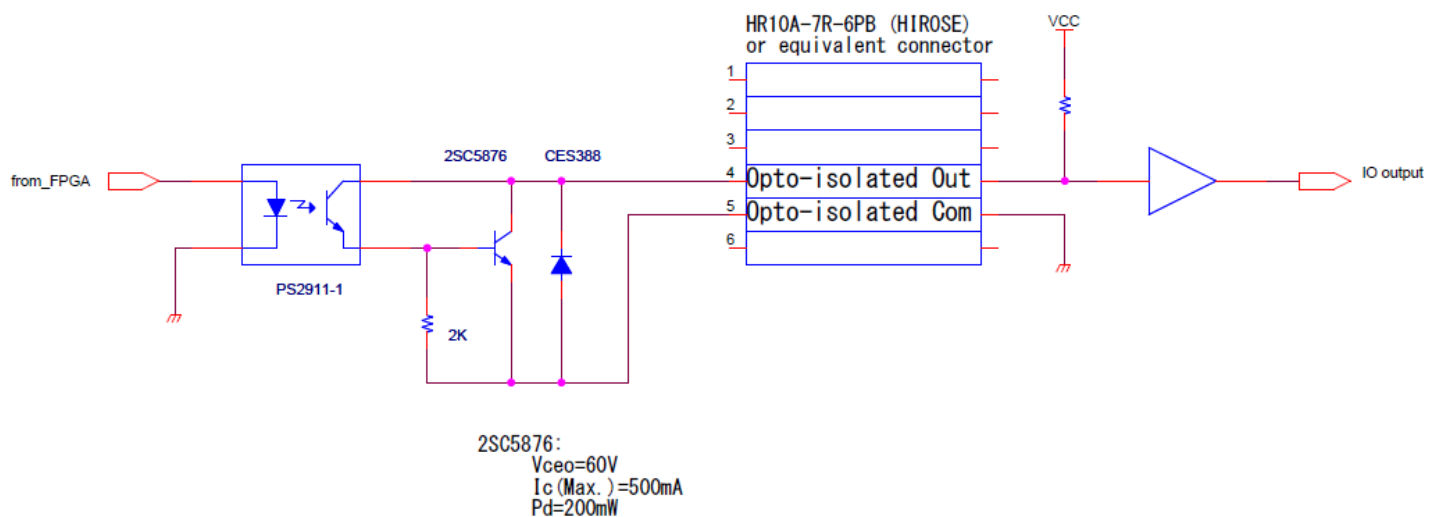

6.2.3 Open Collector GPIO

This GPIO can be used for input or output.

When using as output, it is necessary to have current limiting resistor at outside of camera, to keep current less than 50 mA.

When using as input, current limiting resistor does not necessary. However, camera does not have current limiting circuit on camera. The camera inside circuit may get damage if accidentally uses as output without current limiting resistor. For safety, please add current limiting resistor even use as input.

a) Open Collector GPIO uses as output

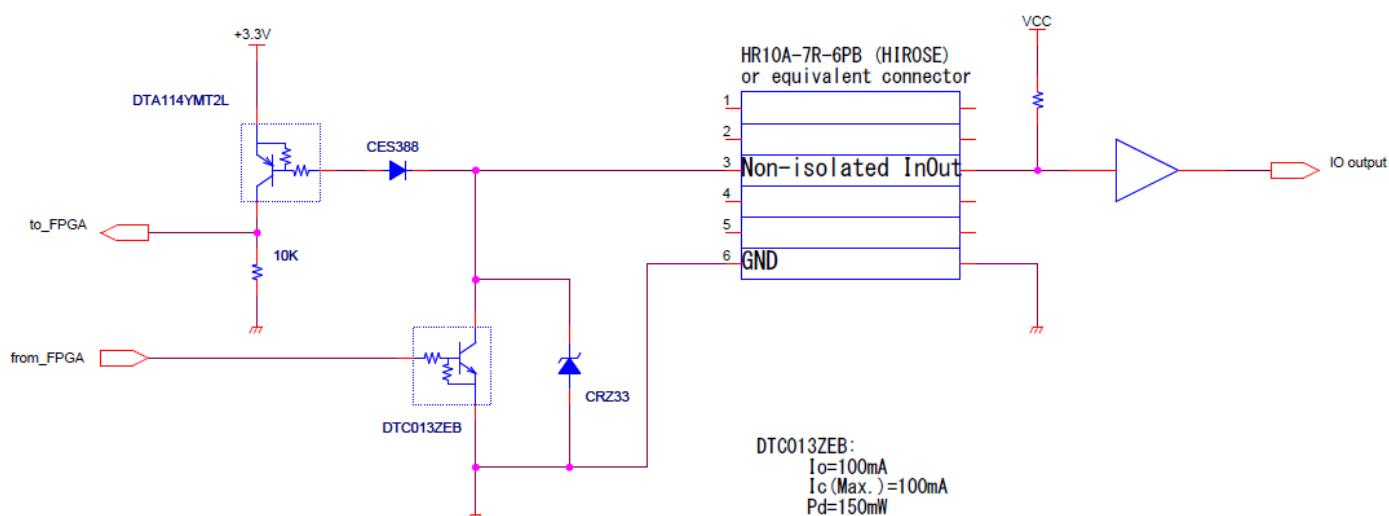

b) Open Collector GPIO uses as input

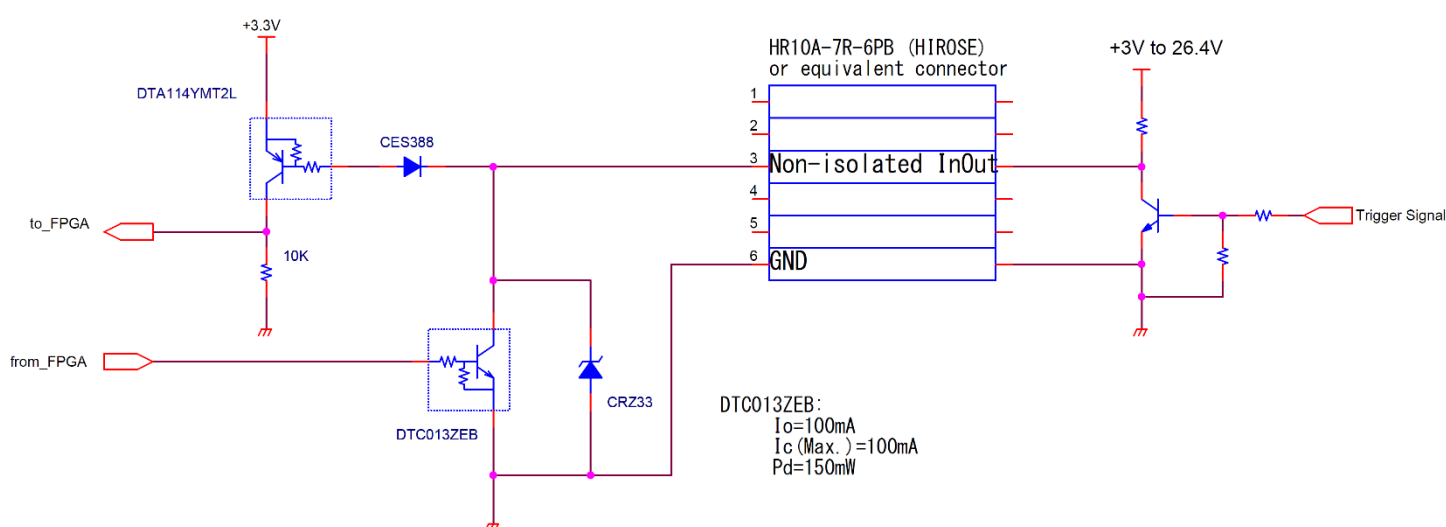

6.2.4 Input and Output Signal Timing (Hardware Trigger)

Case of “External Hardware Trigger”, “Timed Exposure Mode” and “Positive Edge Trigger”

Camera internal processing

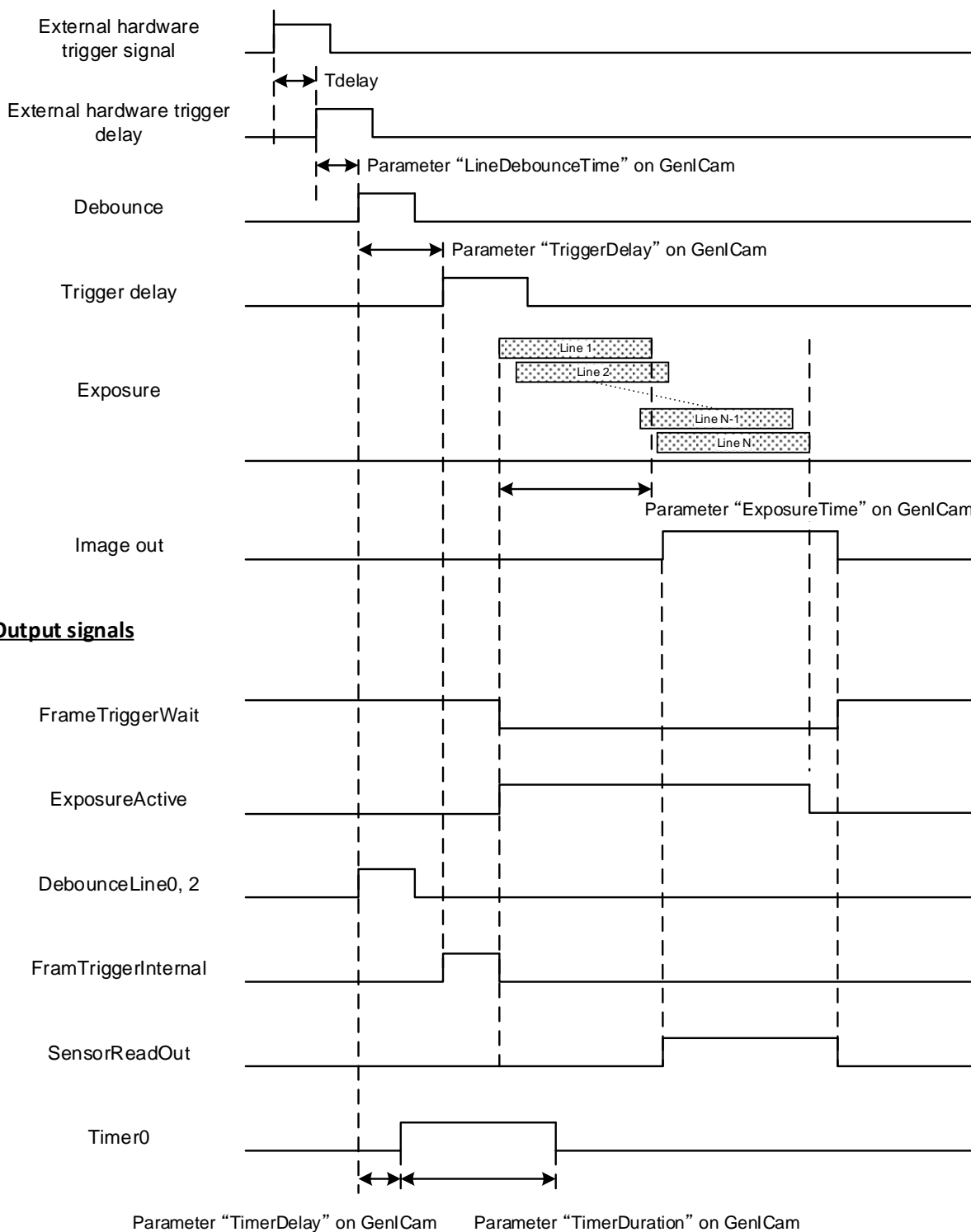

(*1) Please refer to "5.2.6 External Hardware Trigger Input Delay" for more details about "External hardware trigger delay"

6.2.5 Input and Output Signal Timing (Software Trigger)

Case of "Software Trigger", "Timed Exposure Mode" and "Positive Edge Trigger"

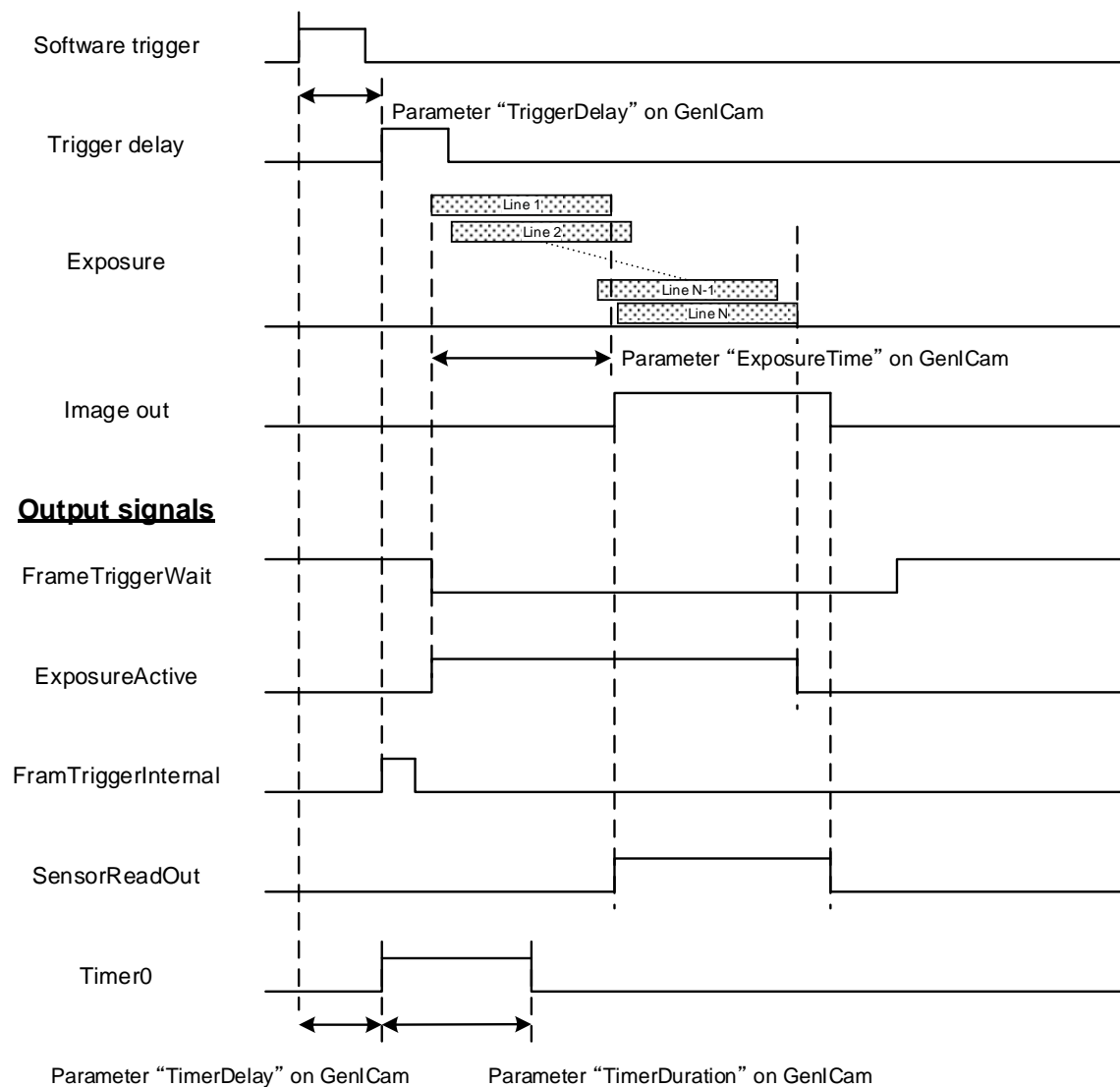
Camera Internal processing

6.2.6 External Hardware Trigger Input Delay

The input trigger signal has some delay inside camera by photo coupler or transistor.
Please refer example measurement of delay in below.

6.2.6.1 External Trigger Signal Delay (Positive polarity trigger signal)

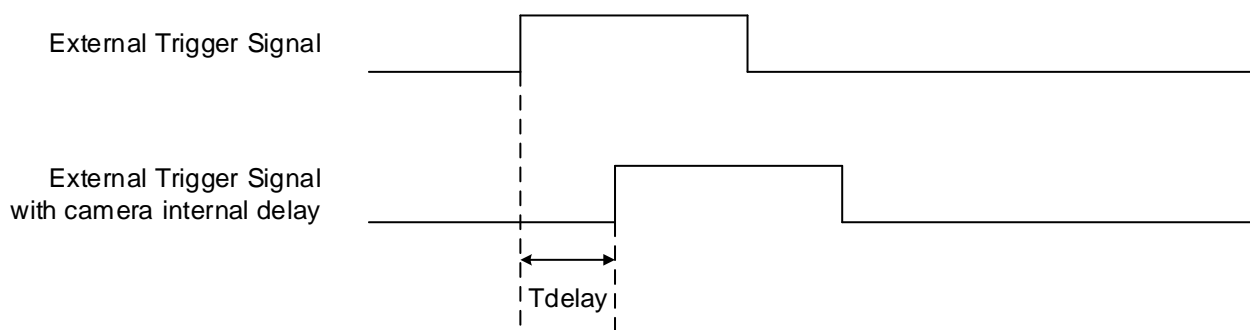

6.2.6.2 External Trigger Signal Delay (Negative polarity trigger signal)

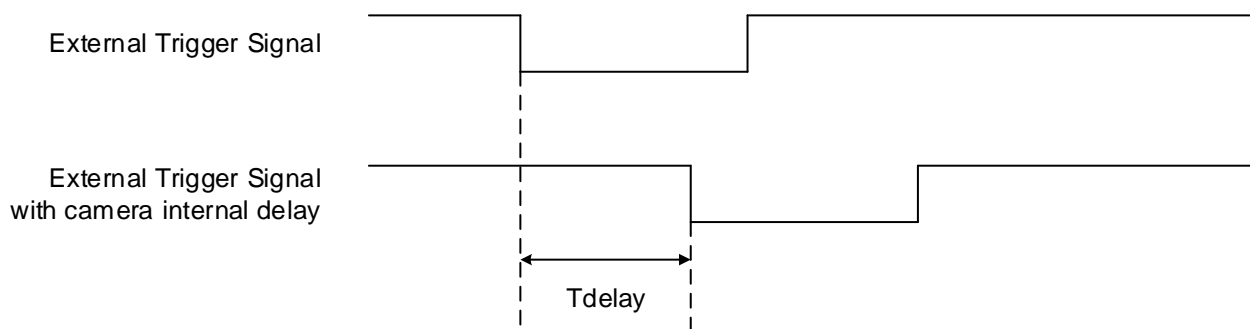

6.2.6.3 Measured External Trigger Signal Delay through Opt-Isolated Port (Line 0)

Measurement circuit

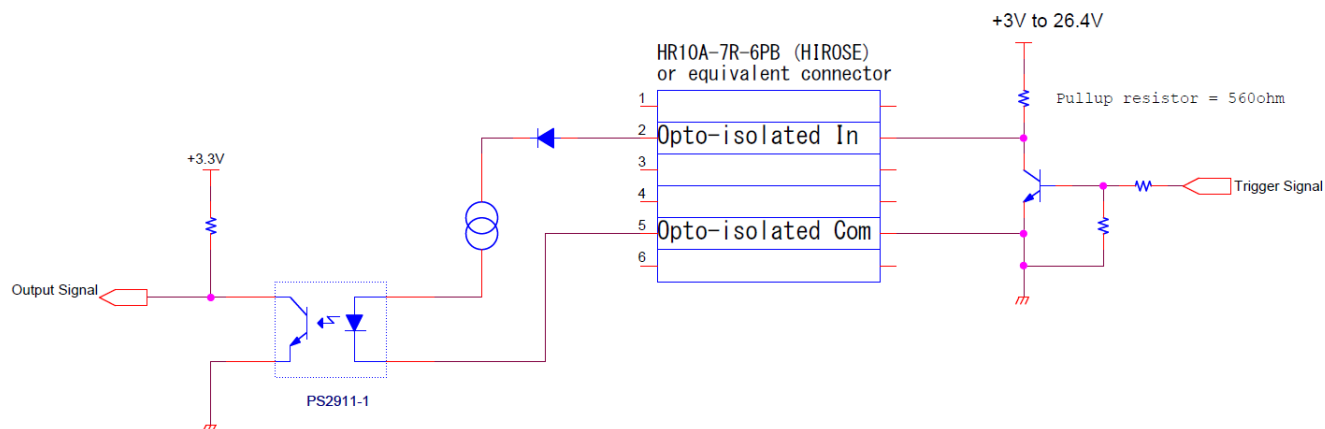

Positive polarity trigger signal

Pull-up voltage	Tdelay	Minimum active pulse duration
+3.3 V	8.2 μ seconds	6 μ seconds
+12 V	4.6 μ seconds	3 μ seconds
+24 V	4.4 μ seconds	2 μ seconds

Negative polarity trigger signal

Pull-up voltage	Tdelay	Minimum active pulse duration
+3.3 V	47 μ seconds	6 μ seconds
+12 V	53.2 μ seconds	3 μ seconds
+24 V	53.2 μ seconds	2 μ seconds

Note. Please use this measured delay as reference. The delay time may fluctuate depending on photo coupler variation, pull-up voltage and pull-up resistor.

6.2.6.4 Measured External Trigger Signal Delay through Open Collector GPIO Port (Line 2)

Measurement circuit

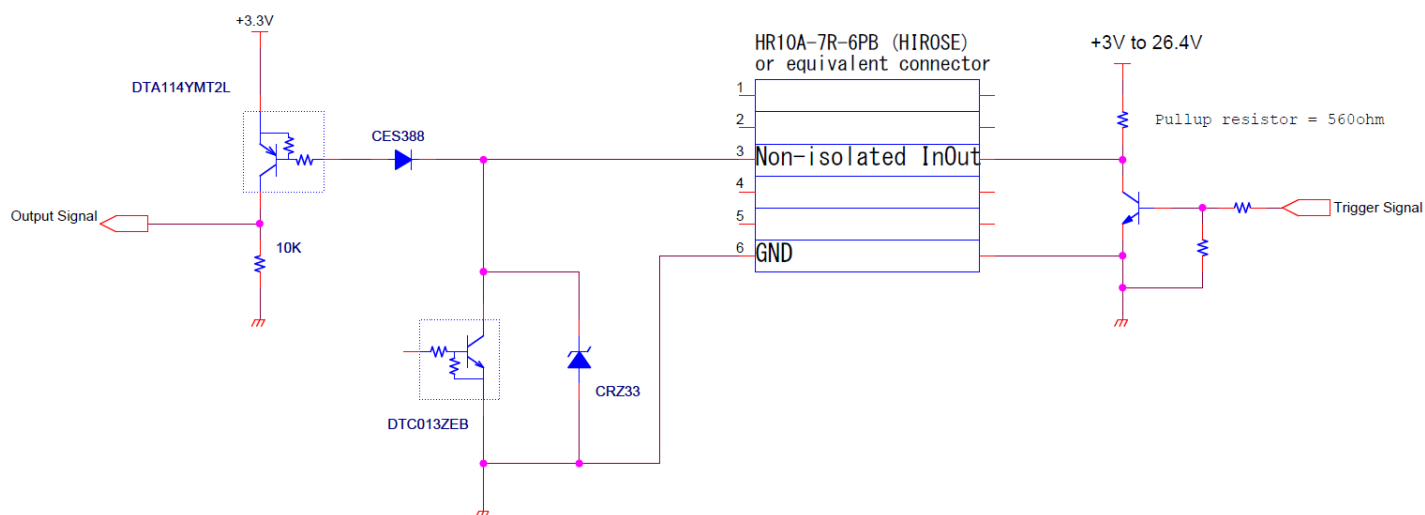

Positive polarity trigger signal

Pull-up voltage	Tdelay	Minimum active pulse duration
+3.3 V	3.9 μ seconds	6 μ seconds
+12 V	3.8 μ seconds	3 μ seconds
+24 V	2.2 μ seconds	2 μ seconds

Negative polarity trigger signal

Pull-up voltage	Tdelay	Minimum active pulse duration
+3.3 V	0.6 μ seconds	6 μ seconds
+12 V	0.8 μ seconds	3 μ seconds
+24 V	0.8 μ seconds	2 μ seconds

Note. Please use this measured delay as reference. The delay time may fluctuate depending on transistor variation, pull-up voltage and pull-up resistor.

7 Dimensions

7.1 STC-MBA503POE

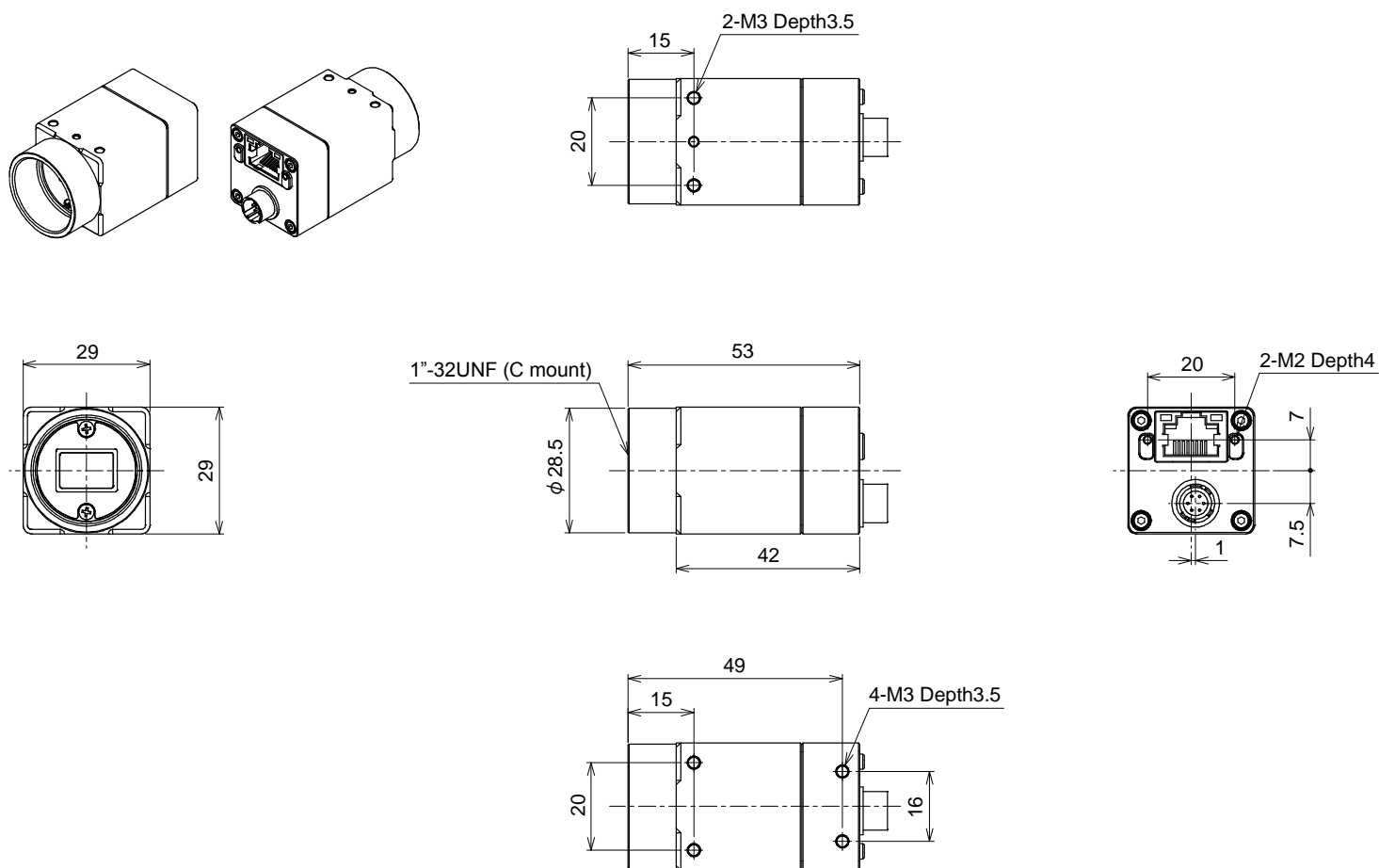

Unit: mm

7.2 STC-MCA503POE

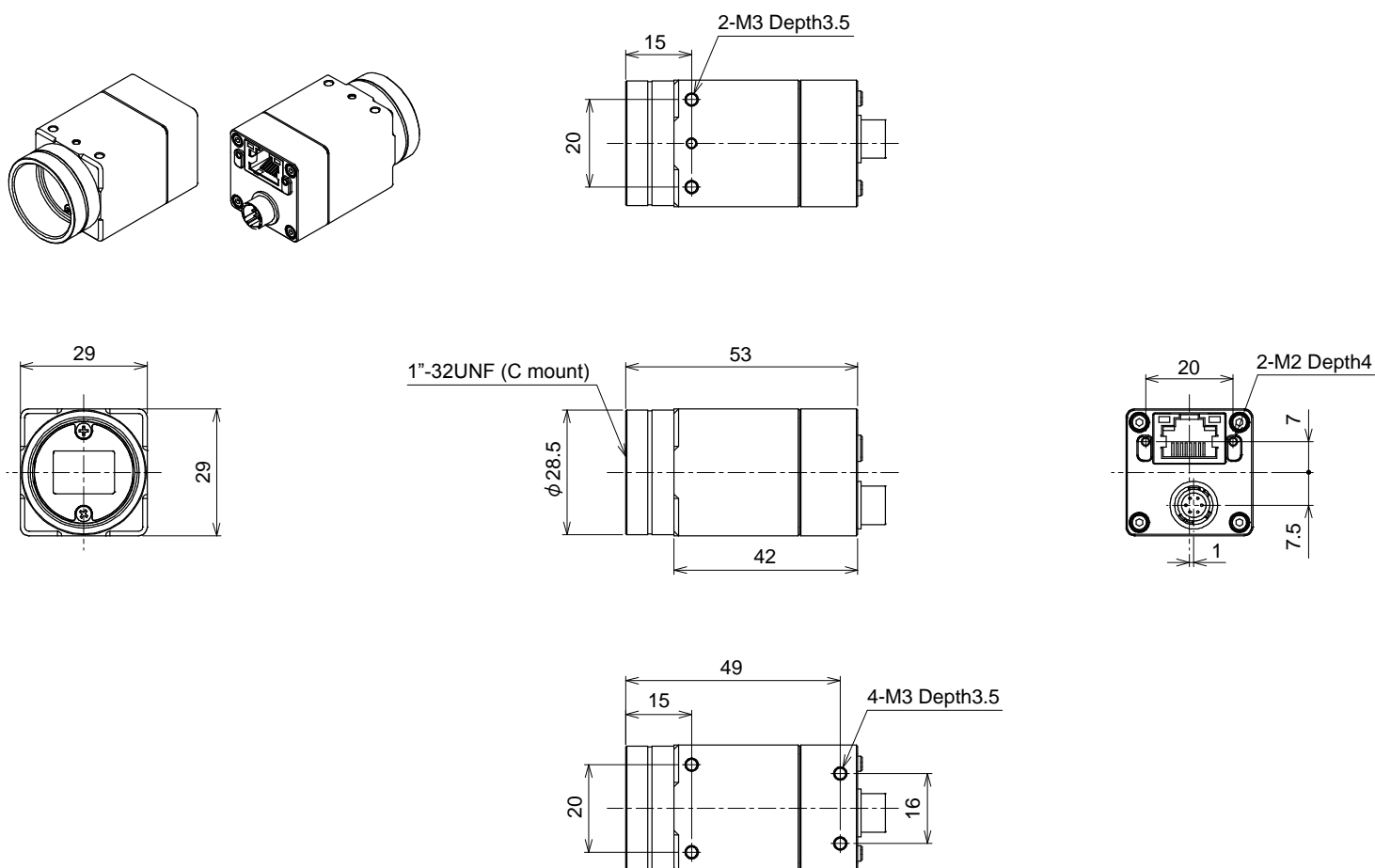

Unit: mm

8 Sensor Information

8.1 Pixel Transferring Image

STC-MBA503POE (Monochrome)

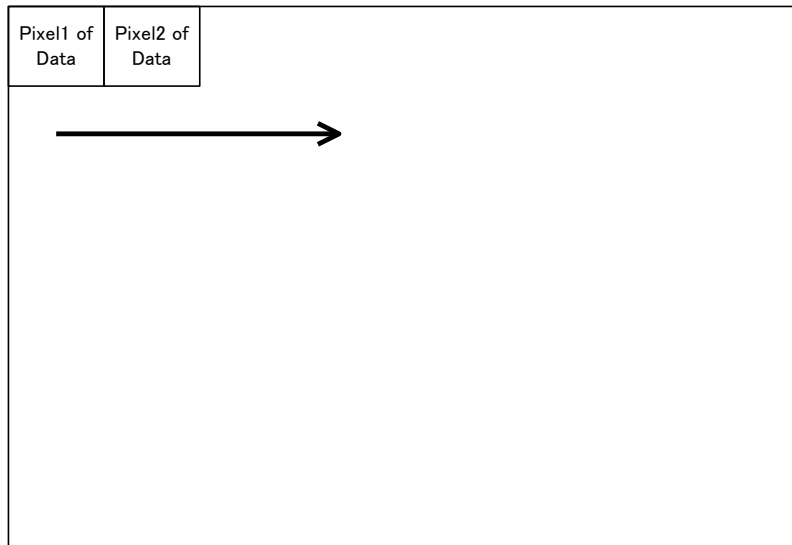

Pixel (m) of Data: mth pixel being transferred

STC-MCA503POE (Color)

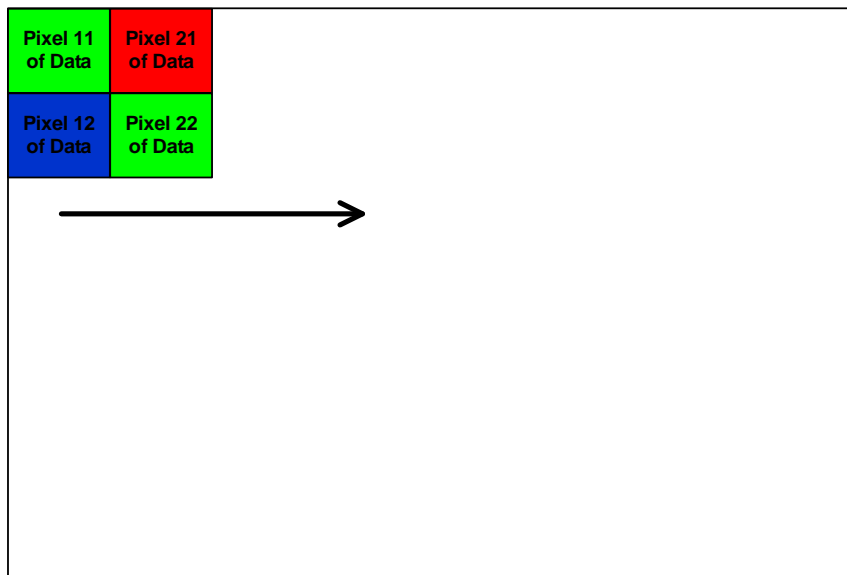

Pixel (m, n) of Data: mth pixel of nth line being transferred

9 Camera Operational Modes

9.1 Normal Mode (Rolling shutter)

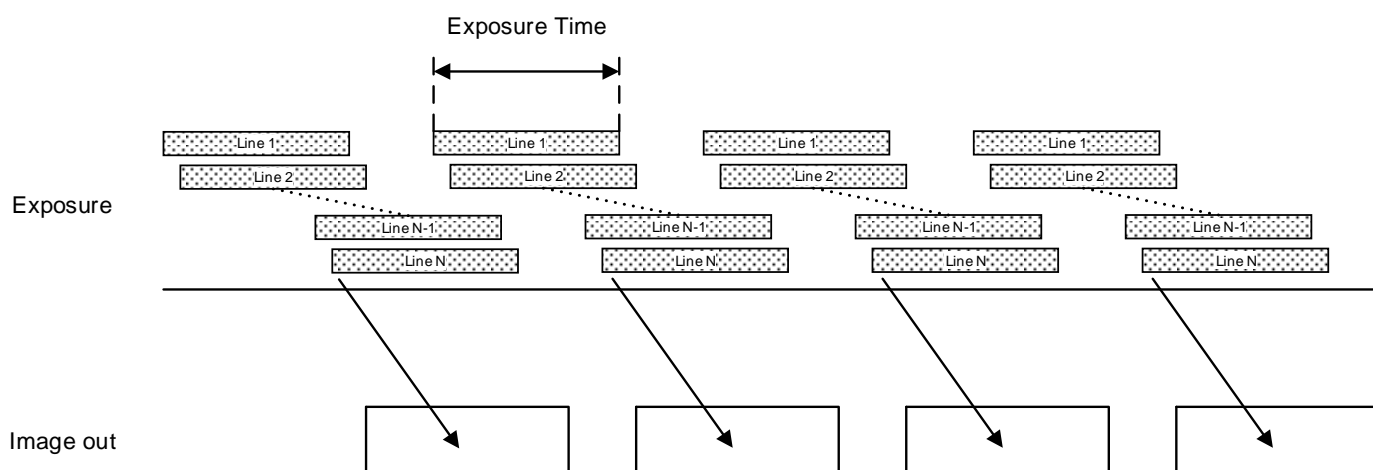

* The exposure time for each line is same.

9.2 Pulse width trigger mode

In this trigger mode with positive polarity, the expose starts at rising edge of trigger signal and stops at falling edge of trigger signal. The expose period is high states of trigger signal.

In this trigger mode with negative polarity, the expose starts at falling edge of trigger signal and stops at rising edge of trigger signal. The expose period is low states of trigger signal.

9.2.1 Timing (when using rolling shutter)

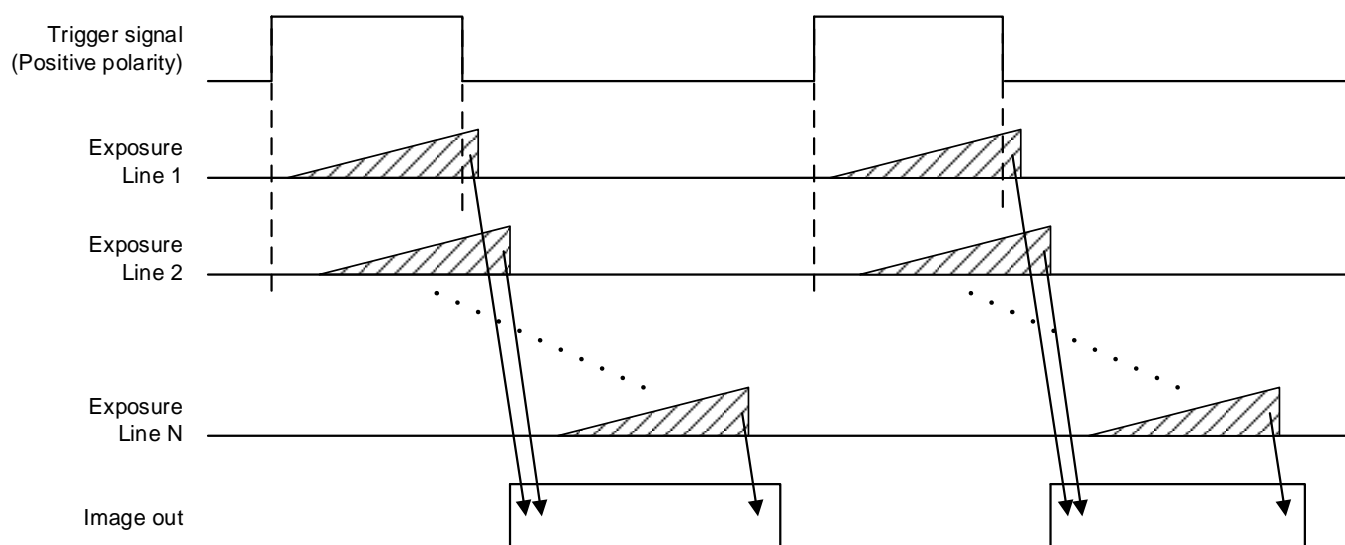

Note: The exposure time is active pulse duration of trigger signal.
Please refers "Exposure Timing" for more details.

9.2.2 Exposure Timing with Positive Polarity Trigger Signal

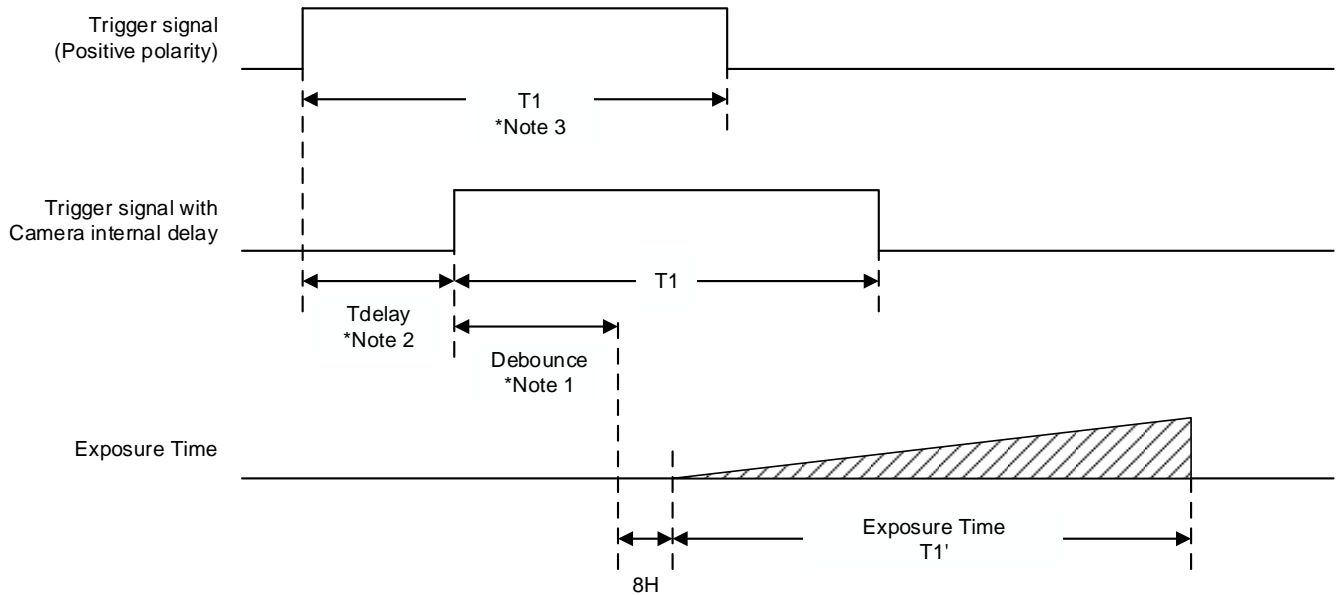

Note 1: The trigger signal will be removed by filtering if active pulse width of input trigger signal is less than “Line Debounce Time” setting time. Please input trigger signal has more than “Line Debounce Time” time active pulse width trigger signal.

Note 2: Please refers “5.2.6 External Hardware Trigger Input Delay” for more details about “External hardware trigger delay”.

Note 3: Please refers “5.2.6 External Hardware Trigger Input Delay” for shortest active pulse duration of trigger signal.

9.2.3 Exposure Timing with Negative Polarity Trigger Signal

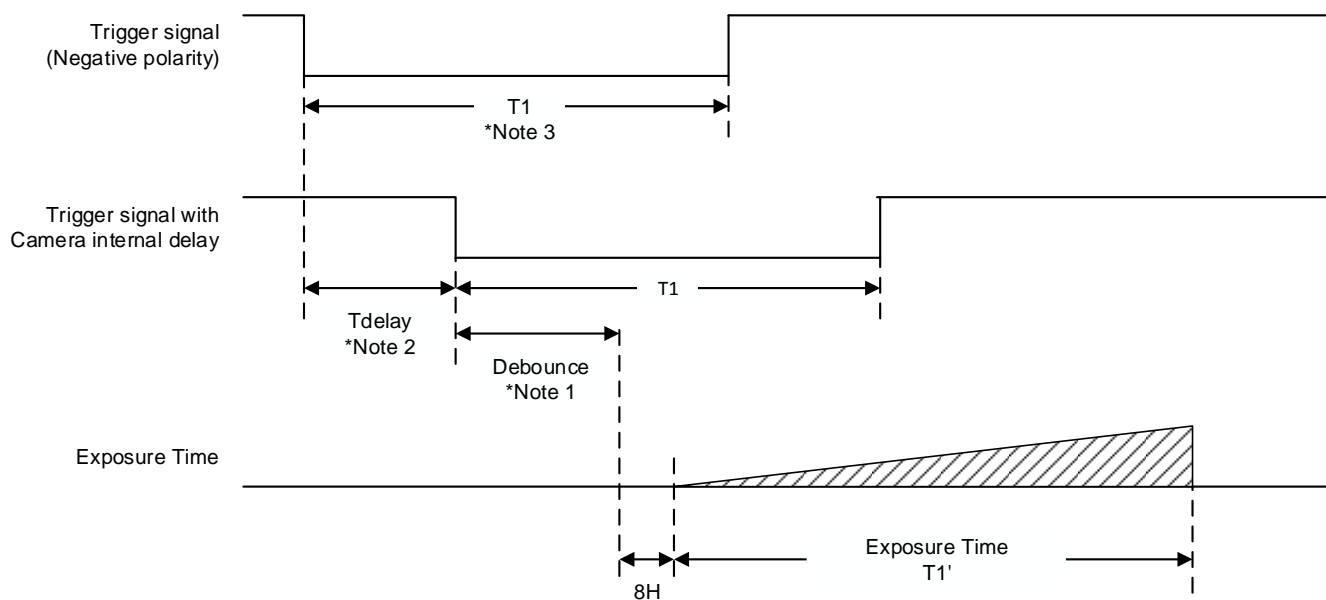

Note 1: The trigger signal will be removed by filtering if active pulse width of input trigger signal is less than “Line Debounce Time” setting time. Please input trigger signal has more than “Line Debounce Time” time active pulse width trigger signal.

Note 2: Please refers “5.2.6 External Hardware Trigger Input Delay” for more details about “External hardware trigger delay”.

Note 3: Please refers “5.2.6 External Hardware Trigger Input Delay” for shortest active pulse duration of trigger signal.

9.3 Edge Preset Trigger Mode

In this trigger mode with positive polarity, the expose starts at rising edge of trigger signal. The exposure duration time is based on preset exposure setting stored by camera setting communication.

In this trigger mode with negative polarity, the expose starts at falling edge of trigger signal. The exposure duration time is based on preset exposure setting stored by camera setting communication.

9.3.1 Timing (When using rolling shutter)

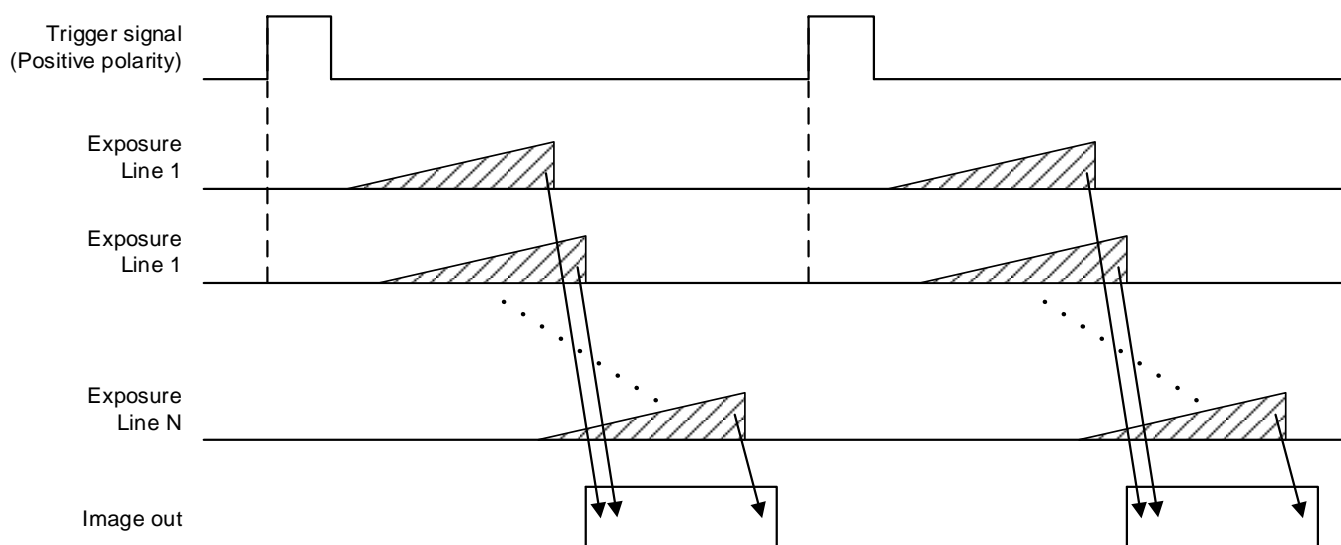

Note: The exposure time is "Exposure Time" on GenICam setting.

9.3.2 Exposure Timing with Positive Polarity Trigger Signal

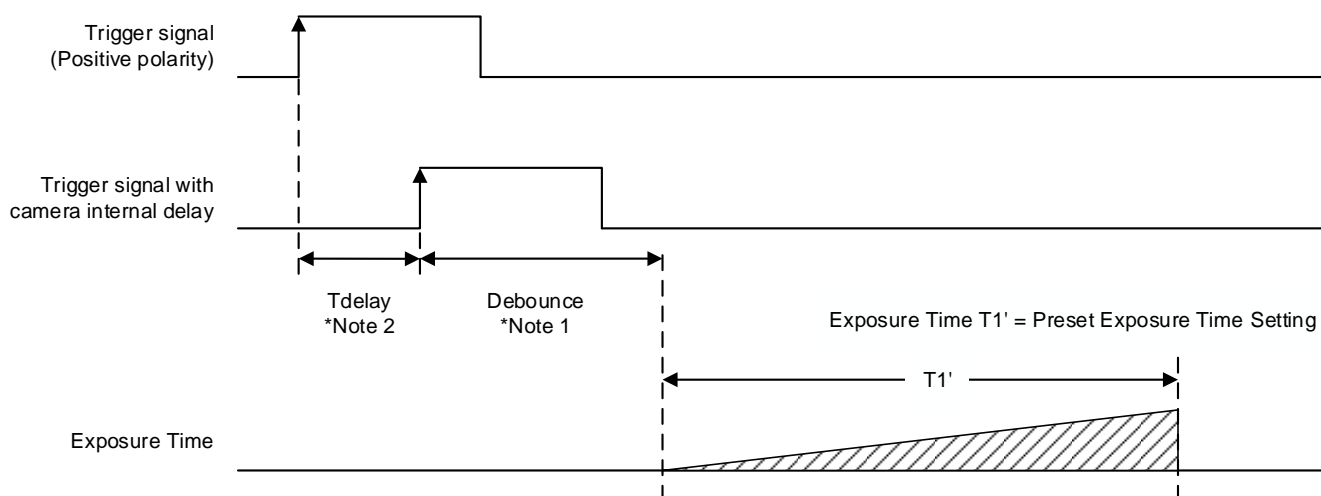

Note 1: The trigger signal will be removed by filtering if active pulse width of input trigger signal is less than “Line Debounce Time” setting time. Please input trigger signal has more than “Line Debounce Time” time active pulse width trigger signal.

Note 2: Please refers “5.2.6 External Hardware Trigger Input Delay” for more details about “External hardware trigger delay”.

9.3.3 Exposure Timing with the Negative Polarity Trigger signal

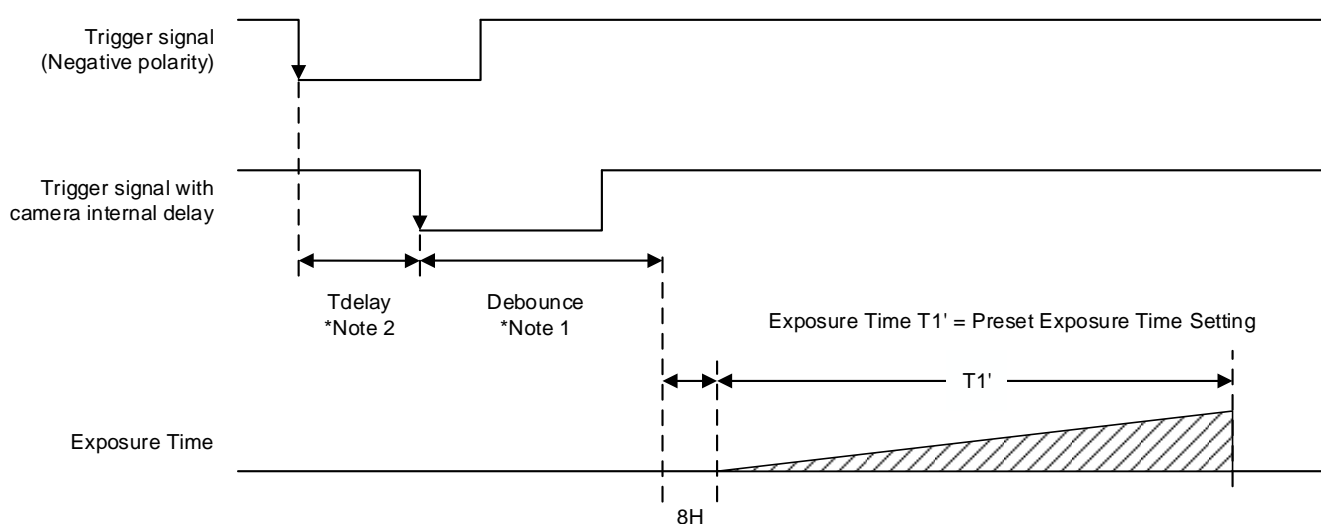

Note 1: The trigger signal will be removed by filtering if active pulse width of input trigger signal is less than “Line Debounce Time” setting time. Please input trigger signal has more than “Line Debounce Time” time active pulse width trigger signal.

Note 2: Please refers “5.2.6 External Hardware Trigger Input Delay” for more details about “External hardware trigger delay”.

9.4 Edge Preset Trigger Mode (Trigger input while image is out)

In this trigger mode with positive polarity, the expose starts at rising edge of trigger signal. The exposure duration time is based on the preset exposure setting stored by camera setting communication.

In this trigger mode with negative polarity, the expose starts at falling edge of trigger signal. The exposure duration time is based on the preset exposure setting stored by camera setting communication.

However, if the trigger signal input while exposing with previous trigger signal or output image, trigger signal is disregard.

9.4.1 Timing

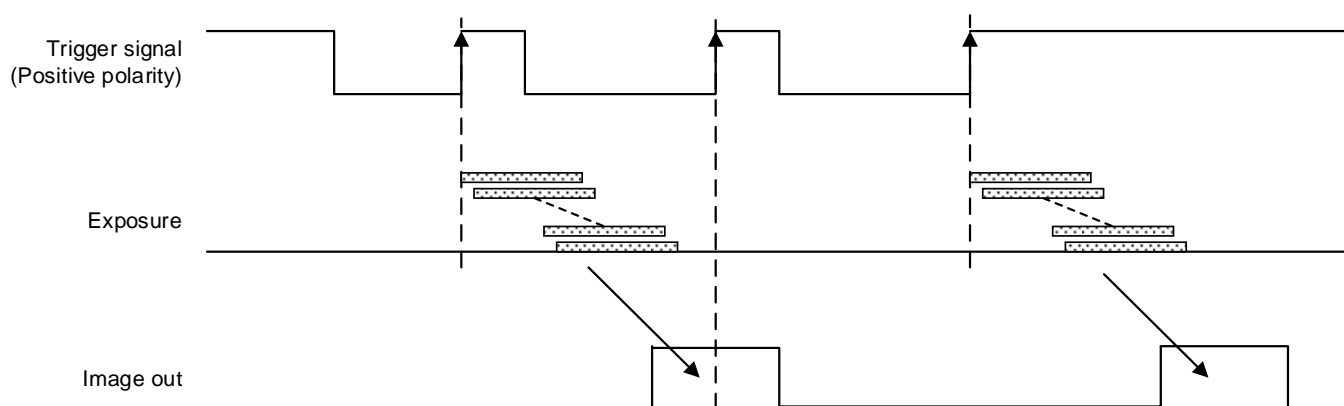

Note: The exposure time is "Exposure Time" on GenICam setting.

10 Camera Functions

10.1 Save and load the camera settings

The camera has the camera setting save function, and camera setting including factory default loads function.

The camera has below two type of camera settings.

Default: The factory default settings (This setting cannot change)

User Set X: Over writeable camera settings (X: 0 to 7)

These camera settings load from ROM to register in RAM on camera, and camera settings at register in RAM on camera save to ROM.

The camera settings saving and loading are controllable with Parameters (“User Set Selector”, “User Set Default Selector”), and commands (“User Set Load”, “User Set Save”) in “User Set Control” category of GenICam.

The details of the parameters and the functions are in the table below:

GenICam Parameters

UserSetSelector	IEnumeration Type	Select “Default” or ”User Set X” “User Set Load” or “User Set Save” process for selected settings.
UserSetLoad	ICommand Type	The camera settings load from ROM to register in RAM.
UserSetSave	ICommand Type	The camera settings at register in RAM save to ROM.
UserSetDefaultSelector	IEnumeration Type	Select which settings (“Default” or “User Set X”) load automatically when camera power is on. This selection saves automatically.

10.1.1 Saving Camera Settings

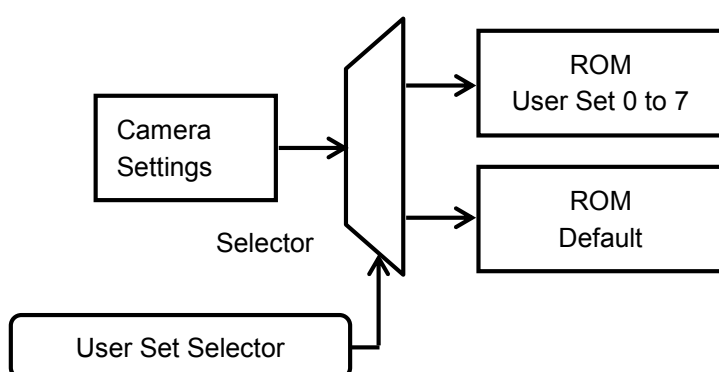

When executing “User Set Save”, camera settings at the register in RAM are saved to the ROM that is selected at “User Set Selector”.

Caution:

“User Set Save” CANNOT execute when “Default” was selected at “User Set Selector”

Setting Procedure

1. Selects “User Set X” at “User Set Selector”
2. Execute “User Set Save”

10.1.2 Loading Camera Settings

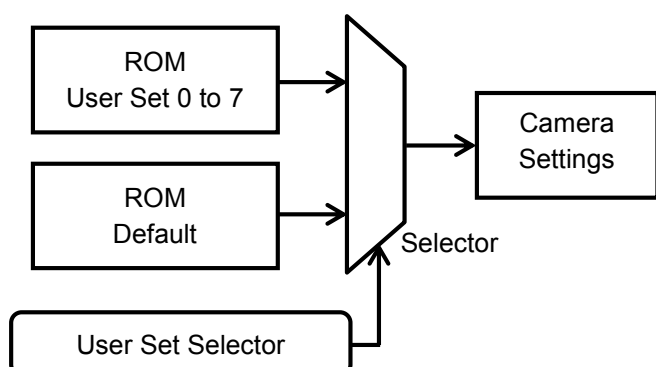

When executing “User Set Load”, camera settings load from selected ROM that was selected at “User Set Selector” to register at RAM.

Setting Procedure

1. Select “User Set X” (or Default) at “User Set Selector”
2. Execute “User Set Load”

10.1.3 Loading Camera Settings when Camera Power is on

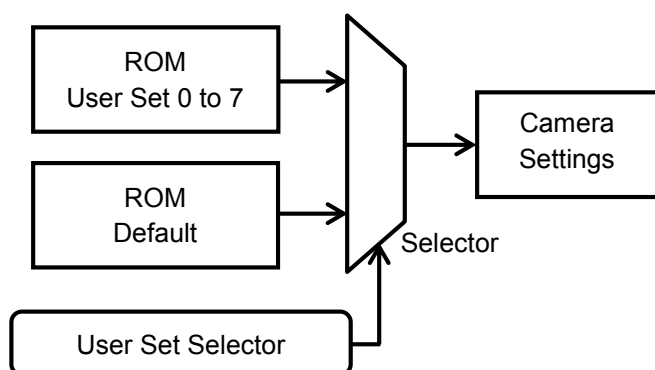

When the camera power is on, camera settings load from selected ROM that was selected at “User Set Default” to register at RAM.

Setting Procedure

1. Set “User Set X” or “Default” at “User Set Default”

10.1.4 Camera Settings Initialization

Please follow the procedure in below for camera settings put back to factory default settings.

Setting Procedure

1. Selects “Default” at “User Set Selector”.
2. Executes “User Set Load”.
3. Select “User Set X” at “User Set Selector”.
4. Executes “User Set Save”.

10.2 Frame rate

This parameter sets the frame rate (fps) of output image from camera.

GenICam Parameters

AcquisitionFrameRate	IFloat Type	Sets frame rate in Hz unit (*1) Range is changed with exposure time setting Default: 14.076502
----------------------	-------------	--

(*1) The approximate value of set value, sets to camera and display it.

10.3 Gain

The gain has Analog Gain, Digital Gain.

10.3.1 Analog Gain

This parameter sets analog gain.

Selects "Analog ALL" at "Gain Selector", sets gain at "Gain".

GenICam Parameters

GainSelector	IEnumeration Type	Selects control gain Analog All: Analog Gain
Gain	IFloat Type	Analog Gain Range: 0 to 55 Default: 0

Analog Gain Formula

$$\text{Gain (x times)} = 1 + (\text{"Analog Gain"} / 8)$$

10.3.2 Digital Gain

This parameter sets digital gain.

Selects "Digital ALL" at "Gain Selector", sets gain at "Gain".

GenICam Parameters

GainSelector	IEnumeration Type	Selects control gain Digital All: Digital Gain
DigitalGain	IFloat Type	Digital Gain Range: 0 to 511 Default: 0

Digital Gain Formula

$$\text{Gain (x times)} = 1 + (\text{"Digital Gain"} / 128)$$

10.4 Exposure Time

This parameter sets variable exposure time.

The control method is selectable from

Manual exposure control, which uses preset exposure time.

Auto exposure control, which is maintain exposure time with brightness of target.

GenICam Parameters

ExposureMode	IEnumeration Type	Exposure control selection Selection: "Off" and "Timed" Off: Exposure time is "1 / Frame rate" Timed: Exposure time is "Exposure Time"
ExposureTime [ExposureTime Selector]	IFloat Type	Exposure time (in μ second) (*1) Range: 31.940000 to 16,777,200.420000 Default: 70,744.920000
ExposureAuto	IEnumeration Type	Auto exposure ON / OFF selection (*2)

(*1) The approximate value of set value, sets to camera and display it.

(*2) Please sets range of auto exposure control with "Exposure Auto Limit Min" and "Exposure Auto Limit Max" when using auto exposure control.

10.5 Black Level

This parameter sets the black level (clamp level for black signal).

Sets the black level at "Black Level".

The lower limit of signal is clamped at this setting level. The signal does not lower than this.

GenICam Parameters

BlackLevel	IFloat Type	Black Level Range: 12bits output: 0 to 4,095 10bits output: 0 to 1,023 8bits output: 0 to 255 Default: 0
------------	-------------	---

10.6 ALC (Auto Light Control)

ALC function has two control methods, which is AGC (Auto Gain Control) and auto shutter. The AGC and auto shutter can be set individually.

The camera parameters are adjusted to brightness of image is maintained with target brightness automatically with ALC function.

AGC or auto shutter have to set “On” to activate ALC function.

GenICam Parameters (for AGC and auto shutter)

AutoLuminanceTarget	Integer Type	Target brightness Range: 0 to 255 Default: 128
AutoLuminanceRegion Selector	Enumeration Type	ALC weight region to set area, position and weight Selection: Region 0 to Region 8
AutoLuminanceWidth	Integer Type	Width for selected ALC weight region Range: 4 to 2,592 Default: 842 for all regions
AutoLuminanceHeight	Integer Type	Height for selected ALC weight region Range: 2 to 1,944 Default: 624 for all regions
AutoLuminance OffsetX	Integer Type	Horizontal offset for selected ALC weight region Range: 0 to 2,588 Default: 32 (Region 0, 3 and 6), 874 (Region 1, 4 and 7), 1,717 (Region 2, 5 and 8)
AutoLuminance OffsetY	Integer Type	Vertical offset for selected ALC weight region Range: 0 to 1,942 Default: 36 (Region 0 to 2), 660 (Region 3 to 5), 1,284 (Region 6 to 8)
AutoLuminanceWeight	Integer Type	Weight Range: 0 to 15 Default: 1 * Sets 10 on Region 4 only Sets the weight for each weight area.
AutoLuminancePeak	Integer Type	Importance ratio for the brightness peak at ALC control. Range: 0 to 255 Default: 0

Target Brightness Formula (Auto Luminance Target)

12bits output: Target Brightness (Gradient) = "Auto Luminance Target" × 16

10bits output: Target Brightness (Gradient) = "Auto Luminance Target" × 4

8bits output: Target Brightness (Gradient) = "Auto Luminance Target"

About the importance ratio for brightness peak at ALC control (Auto Luminance Peak)

When setting 0, Average: 100 %, Peak: 0 %. The ALC control with brightness average.

When setting 255, Average: 0 %, Peak: 100 %. The ALC control with brightness peak.

When setting 128, Average: 50 %, Peak: 50 %.

10.6.1 ALC control method

The ALC control with weight region 0 to 8.

The weight area setting parameters are in below:

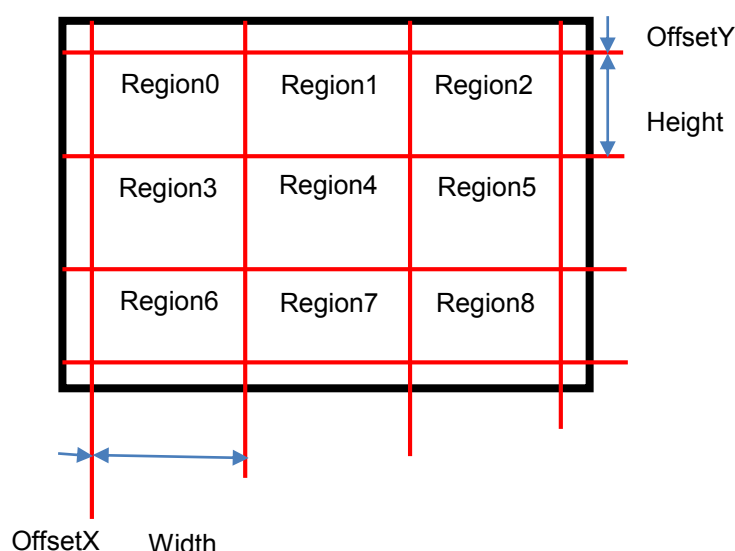

The brightness average and peak calculate for each weight area.

The target brightness comparison value calculates with "Auto Luminance Peak", the brightness average and peak then compare with target brightness to define necessary brightness control (to dark or to bright). The brightness of image maintains to "Auto Luminance Target" with AGC and auto shutter functions.

If AGC and auto shutter are ON for ALC control, auto shutter function maintains brightness first. The AGC function maintains brightness if brightness cannot maintain to "Auto Luminance Target" with auto shutter.

10.6.2 AGC (Auto Gain Control)

The brightness of image maintains to keep target brightness with gain automatically.

If the brightness of image is darker than target brightness, gain increases up to "Gain Auto Limit Max".

If the brightness of image is brighter than target brightness, gain decreases.

GenICam Parameters

GainSelector	IEnumeration Type	Adjustable gain selection Selected gain can be adjusting by Gain[GainSelector]. Please select "Analog All" when AGC is turned on. Selection: "Analog All" (analog gain) and "Digital All" (digital gain) Default: "Analog All"
Gain[GainSelector]	IFloat Type	Gain Selected gain at "Gain Selector" is adjusting Analog gain: Range: 0 to 55 Default: 0 Digital gain: Range: 0 to 511 Default: 0 Analog gain cannot adjustable when AGC is turned on.
GainAuto [GainSelector]	IEnumeration Type	AGC ON / OFF selection Selection: "ON" (Continuous) and "OFF" (Off) Default: OFF
GainAutoLimitMin [GainSelector]	IFloat Type	Minimum analog gain for AGC Range: 0 to 55 Default: 0 This cannot be set greater than "Gain Auto Limit Max"
GainAutoLimitMax [GainSelector]	IFloat Type	Maximum analog gain for AGC Range: 0 to 55 Default: 55 This cannot be set smaller than "Gain Auto Limit Min"

10.6.3 Auto shutter

The brightness of image maintains to keep target brightness with shutter automatically.

If the brightness of image is darker than target brightness, exposure time extends up to “Exposure Auto Limit Max”.

If the brightness of image is brighter than target brightness, exposure time becomes shorter up to “Exposure Auto Limit Min”.

GenICam Parameters

ExposureAuto	IEnumeration Type	Auto shutter ON / OFF selection Selection: “ON” (Continuous), “OFF” (Off) Default: “OFF”
ExposureAutoLimitMin	IFloat Type	Minimum exposure time (in μ second) for auto shutter Range: 32 to 16,777,000 Default: 32
ExposureAutoLimitMax	IFloat Type	Maximum exposure time (in μ second) for auto shutter Range: 213 to 16,777,200 Default: 70,744

10.6.4 ALC settings procedure

ALC Settings Procedure

1. Sets “Auto Luminance Width”, “Auto Luminance Height”, “Auto Luminance Offset X”, “Auto Luminance Offset Y” and “Auto Luminance Weight” for “Auto Luminance Region 0 to 8”.
2. Sets “Continuous” for “Gain Auto” when using AGC function.
3. Sets “Gain Auto Limit Min” and “Gain Auto Limit Max” when using AGC function.
4. Sets “Continuous” for “Exposure Auto” when using auto shutter function.
5. Sets “Exposure Auto Limit Min” and “Exposure Auto Limit Max” when using auto shutter function.
6. Sets “Auto Luminance Target”.

10.7 White balance (Only available for color camera)

The color compensates with gain adjustment each color.

The gain for each color has to adjust each color has same brightness when taking flat white target.

The white balance control methods are listed in below:

OFF

Auto white balance

Push to set white balance

Preset 0 to 2

10.7.1 White balance control methods

GenICam Parameters

BalanceRatioSelector	IEnumeration Type	White balance control target color selection Selection: "Red", "Green" and "Blue"
BalanceRatio	IFloat Type	Color gain setting for color selects at "Balance Ratio Selector" Range: 0 to 255
BalanceWhiteAuto	IEnumeration Type	White balance control method selection. Selection: "Off", "Once", "Continuous", "Preset 0", "Preset 1" and "Preset 2" Default: "Off"

10.7.2 White balance control method selection

OFF

The white balance with "Balance Ratio" setting for Red, Green and Blue.

If the white balance process is not necessary, please sets 0 for "Balance Ratio" for all colors.

White balance "OFF" setting procedure

1. Sets "Off" at "Balance White Auto".

Auto white balance

The optimized white balance gain calculates each frame for auto white balance.

Auto white balance setting procedure

1. Sets "Continuous" at "Balance White Auto".

Push to set white balance

The white balance gain adjusts once after select this white balance then set to "Balance Ratio" for all colors.

Sets "OFF" at "Balance White Auto" automatically after sets "Balance Ratio" for all colors.

Push to set white balance setting procedure

1. Sets the flat white target then acquires image.
2. Sets "Once" at "Balance White Auto".

Preset white balance 0 to 2

The camera has three preset manual white balances.

Preset white balance setting procedure

1. Selects "Preset 0" to "Preset 2" at "Balance White Auto".
2. Selects adjusting color from Red, Green or Blue at "Balance Ratio Selector".
3. Sets gain for selected adjusting color at "Balance Ratio".

The settings can be save into camera with "User Set Control" function.

10.7.3 White balance calculate region setting

The size and position for white balance gain calculation region are changeable.

GenICam Parameters

BalanceWhiteAuto RegionSelector	IEnumeration Type	White balance gain calculation region selection Selection: Region 0
BalanceWhiteAuto Width	Integer Type	Width (horizontal size, in pixel) for white balance gain calculation region Range: 1 to 2,592 Default: 2,592
BalanceWhiteAuto Height	Integer Type	Height (vertical size, in line) for white balance gain calculation region Range: 1 to 1,944 Default: 1,944
BalanceWhiteAuto XOffset	Integer Type	Horizontal offset (in pixel) for region 0 Range: 0 to 2,591 Default: 0
BalanceWhiteAuto YOffset	Integer Type	Vertical offset (in line) for region 0 Range: 0 to 1,943 Default: 0

The white balance calculation region settings are like below:

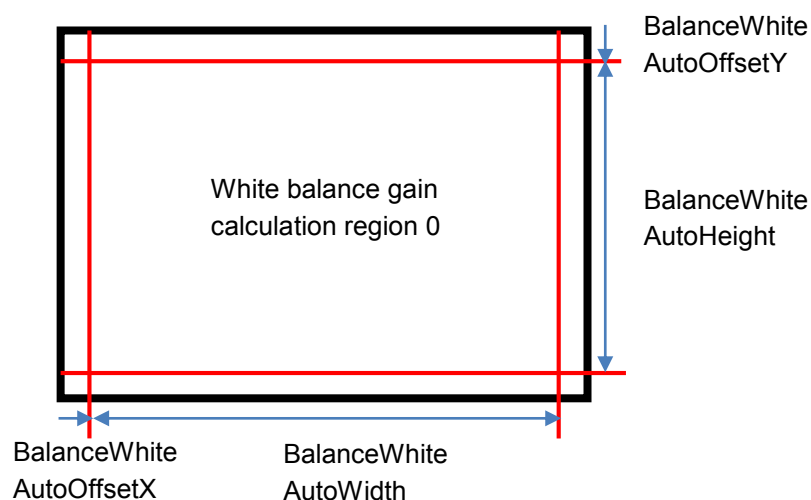

10.8 Gamma correction

The gamma correction is changeable.

GenICam Parameters

Gamma	IFloat Type	Gamma correction Range: 0 to 4.0 Default: 1.0
-------	-------------	---

10.9 ROI (Region of Interest)

The specified region of image can be output from camera with ROI function.

GenICam Parameters

Width	Integer Type	Width (horizontal size) of output image (in pixel) Range: 8 to 2,592 Default: 2,592 Adjustable steps: 8 ("Width" + "Offset X") should not exceeded maximum width.
Height	Integer Type	Height (vertical size) of output image (in line) Range: 2 to 1,944 Default: 1,944 Adjustable steps: 2 ("Height" + "Offset Y") should not exceeded maximum height.
OffsetX	Integer Type	Horizontal offset for output image (in pixel) Range: 0 to 2,584 Default: 0 Adjustable steps: 8
OffsetY	Integer Type	Vertical offset for output image (in line) Range: 0 to 1,942 Default: 0 Adjustable steps: 2

The ROI region settings are below:

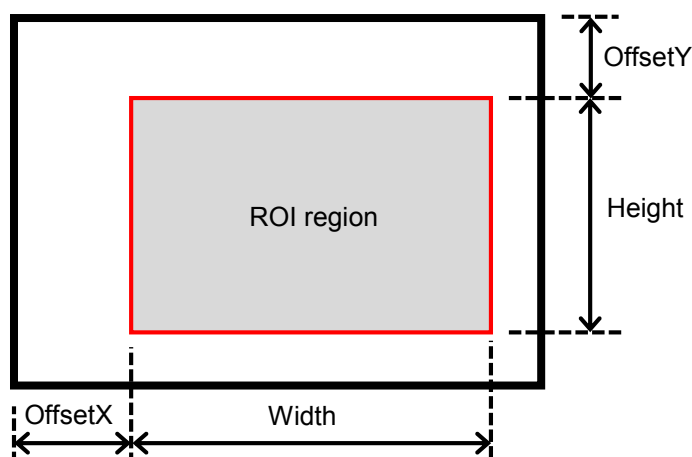

10.10 Pixel Format

The image format from camera can be set on Pixel Format.

GenICam Parameters

PixelFormat	IEnumeration Type	Pixel Format
-------------	-------------------	--------------

The following chart shows the available Pixel Formats on camera:

Output Bits	Pixel Format		
	Monochrome Camera STC-MBA503POE	Color Camera STC-MCA503POE	
8bits	Mono8	Mono8	BayerGR8
10bits	Mono10	Mono10	BayerGR10
10bits Packed	Mono10Packed	Mono10Packed	BayerGR10Packed
12bits	Mono12	Mono12	BayerGR12
12bits Packed	Mono12Packed	Mono12Packed	BayerGR12Packed
8bits x 3	N/A	RGB8	

Each format specified on GenICam PFNC (Pixel Format Naming Convention).

10.11 Binning

Binning is added (sum) adjacent pixels into one pixel.

The pixel data inside of red square add or average as one pixel.

The sensitivity is increasing when added adjacent pixels.

The noise is reducing when averaged adjacent pixels.

Only average is available for horizontal binning

<STC-MBA503POE>

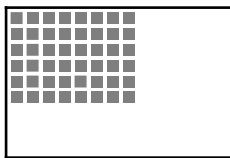

Binning X (1), Y (1)

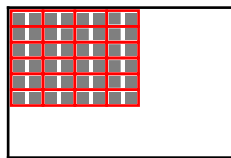

Binning X (2), Y (1)

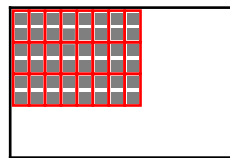

Binning X (1), Y (2)

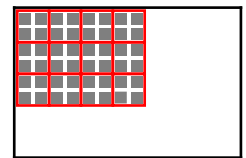

Binning X (2), Y (2)

<STC-MCA503POE>

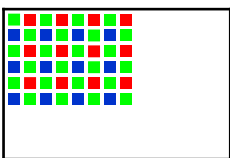

Binning X (1), Y (1)

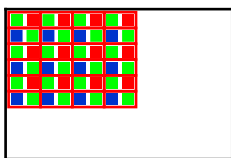

Binning X (2), Y (1)

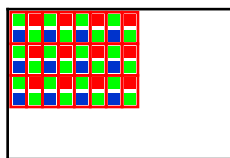

Binning X (1), Y (2)

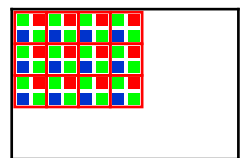

Binning X (2), Y (2)

GenICam Parameters

BinningHorizontal Mode	IEnumerationType	Sets Binning mode for horizontal binning Selection: Sum, Average Default: Average
BinningHorizontal	Integer Type	Sets binning on horizontal direction 1: Binning Off (Default) 2: x2 Binning 4: x4 Binning
BinningVertical	Integer Type	Sets binning on vertical direction 1: Binning Off (Default) 2: x2 Binning 4: x4 Binning

(*1) Decimation is update automatically when selecting x2 or x4 binning.

(*2) It is necessary to change exposure time (to shorten exposure time), to increase frame rate when using Binning.

10.12 Decimation

When using Decimation mode, the decimated image can be output.

The images below show decimated pixels (red squares) where they are output.

<STC-MBA503POE>

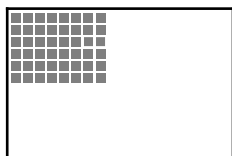

Decimation X (1), Y (1)

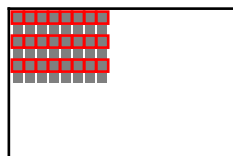

Decimation X (1), Y (2)

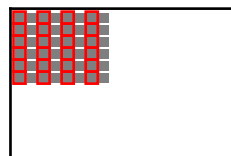

Decimation X (2), Y (1)

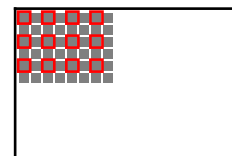

Decimation X (2), Y (2)

<STC-MCA503POE>

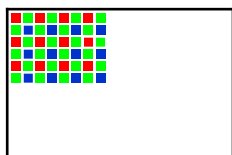

Decimation X (1), Y (1)



Decimation X (1), Y (2)

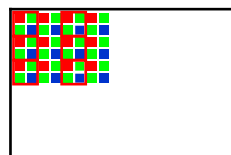

Decimation X (2), Y (1)

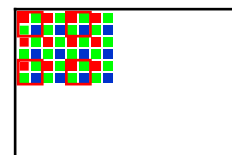

Decimation X (2), Y (2)

GenICam Parameters

DecimationHorizontal	Integer Type	Sets decimation on horizontal direction 1: Disable Decimation (Default) 2: Decimates one of two pixels 3: Decimates two of three pixels 4: Decimates three of four pixels 5: Decimates four of five pixels 6: Decimates five of six pixels 7: Decimates six of seven pixels
DecimationVertical	Integer Type	Sets decimation on vertical direction 1: Disable Decimation (Default) 2: Decimates one of two pixels 3: Decimates two of three pixels 4: Decimates three of four pixels 5: Decimates four of five pixels 6: Decimates five of six pixels 7: Decimates six of seven pixels

(*1) Decimation is update automatically when selecting x2 or x4 binning.

(*2) It is necessary to change exposure time (to shorten exposure time), to increase frame rate when using Decimation.

10.13 Trigger

The trigger type (trigger source) is selectable at "Trigger Source" under "Acquisition Control".
The trigger type (trigger source) is listed in below table.

Software	Software trigger generates by "Trigger Software"
Software Signal 0	Software trigger generates by "Software Signal Control"
Software Signal 1	Software trigger generates by "Software Signal Control"
Action 0	Action command trigger
Line 0	Hardware trigger through "Line 0"
Line 2	Hardware trigger through "Line 2"
Logic Block 0	Trigger generates by "Logic Block Control" Please refers "Trigger signal processing procedure" for more details

10.13.1 Trigger signal processing procedure

The camera internal process for external hardware trigger signal or software trigger signal input is below:

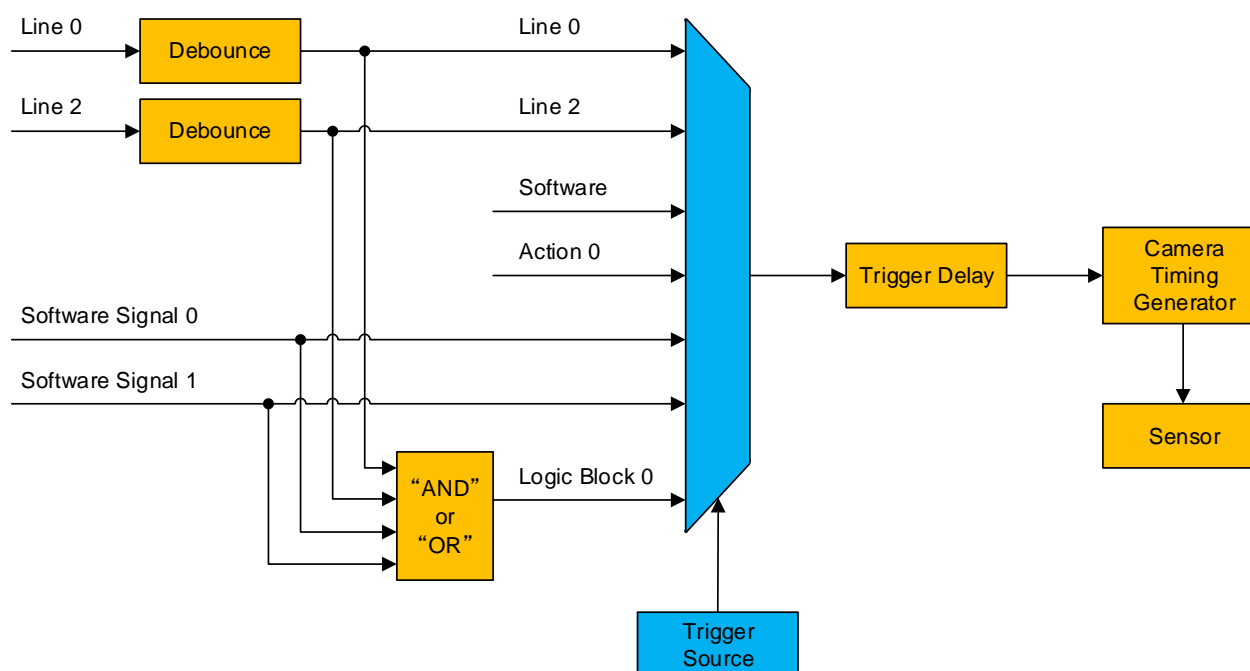

The trigger signal is selectable by GenICam commands.

Trigger Source: select trigger type

10.14 Image Flip

The horizontal flip image can be selected by "Reverse X".
The vertical flip image can be selected by "Reverse Y".

GenICam Parameters

ReverseX	IBoolean Type	Horizontal flip image ON / OFF selection Selection: "False" (Horizontal flip is Off), "True" (Horizontal flip is On) Default: "False" (Horizontal flip is Off)
ReverseY	IBoolean Type	Vertical flip image ON / OFF selection Selection: "False" (Vertical flip is Off), "True" (Vertical flip is On) Default: "False" (Vertical flip is Off)

10.15 LUT Control

The output signal assigned table for input signal.

GenICam Parameters

LUT Selector	IEnumeration Type	Control LUT selection (Luminance is only selectable) Default: Luminance
LUT Enabled	IBoolean Type	LUT ON / OFF selection
LUT Index	IInteger Type	Index for LUT Range: 0 to 4,095
LUT Value	IInteger Type	The output value for input value that specifies by index Range: 0 to 4,095

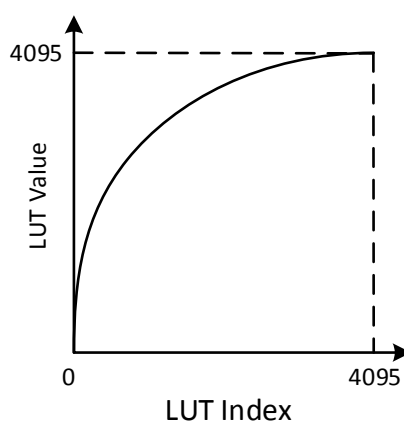

e.g. LUT usage (low brightness level enhancement)

10.16 Defective pixel correction

The selected position of defective pixel is correcting with adjacent pixel information.

The selected position of defective pixel of color camera is correcting with adjacent same color of pixel information.

GenICam Parameters

PixelCorrectionAll	IBoolean Type	Defective pixel correction ON / OFF selection Selection: "True" (On), "False" (Off) Default: "True"
PixelCorrection Enabled	IBoolean Type	Defective pixel correction ON / OFF selection for selected index Selection: "True" (On), "False" (Off) Default: "False" (Off)
PixelCorrection Index	IInteger Type	Index for process defective pixel correction Range: 0 to 2,047 Default: 0
PixelCorrectionX	IInteger Type	Horizontal position for selected index for process defective pixel correction Range: 0 to 2,591 Default: 0
PixelCorrectionY	IInteger Type	Vertical position for selected index for process defective pixel correction Range: 0 to 1,943 Default: 0

10.17 Counter And Timer Control

Controls “Timer” and “Counter”.

A) Timer Control

GenICam Parameters

TimerSelector	IEnumeration Type	Fixed as “Timer 0”
TimerDelay	IFloat Type	Delay for “Timer 0 active” signal (in μ second) Range: 0 to 16,777,215 Default: 0
TimerDuration	IFloat Type	Duration of “Timer 0 active” signal (in μ second) Range: 1 to 16,777,215 Default: 1
TimerTrigger Source	IEnumeration Type	Reference signal selection to generate “Timer 0 active” signal Default: “Off”
TimerTrigger Activation	IEnumeration Type	Polarity of reference signal to generate “Timer 0 active” signal Default: “Rising Edge”
TimerValue	IFloat Type	Returns value for “Timer 0 active” signal

When the timing of “Timer 0 active” signal is adjusting to active signal of Exposure, “Timer 0” can be used as strobe control signal.

B) Counter Control

GenICam Parameters

CounterSelector	IEnumeration Type	Counter selection Default: “Counter 0”
CounterEvent Source	IEnumeration Type	Counter event source selection
CounterReset Source	IEnumeration Type	Reference signal selection to reset counter
CounterReset Activation	IEnumeration Type	Polarity of reference signal to reset counter
CounterReset	ICommand Type	Rest switch “Activate as switch when selecting “Software” at “Counter Reset Source”
CounterValue	IInteger Type	Returns number of counter

10.18 Event Control

The camera internal signal can be output as specified event information, like “exposure end”, to PC used by GVCP (GigE Vision Control Protocol).

e.g. Event control
Notified “Exposure End”

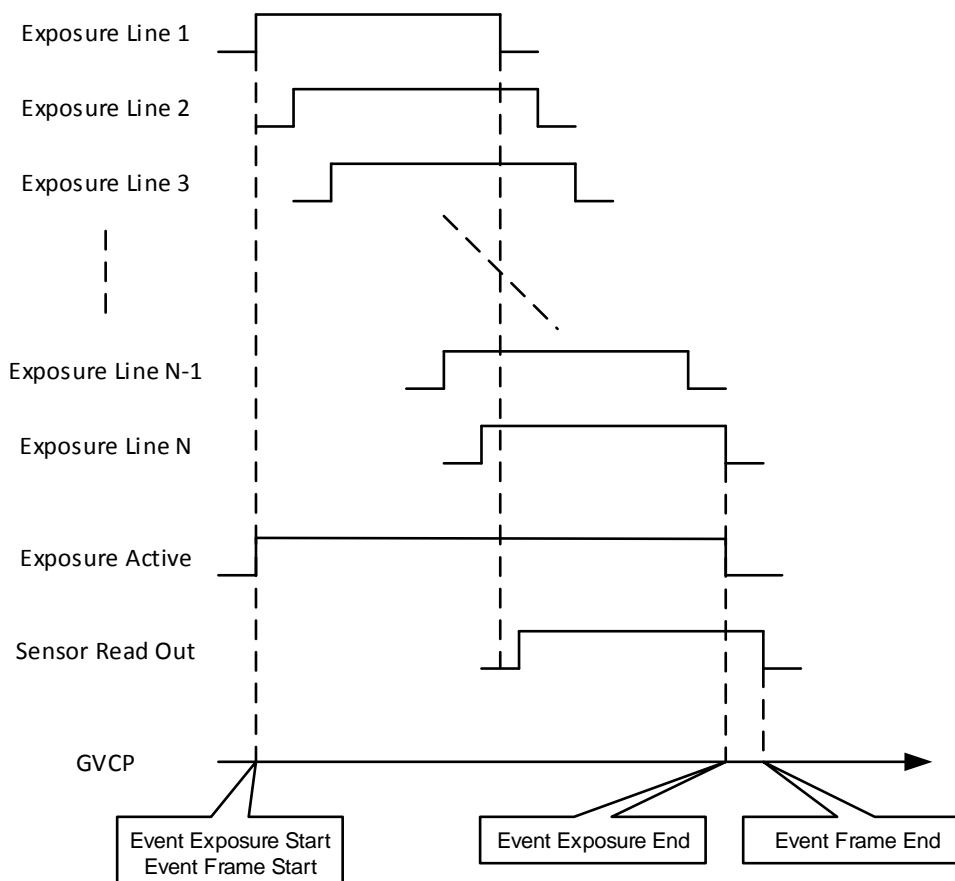

GenICam Parameters

Event Selector	IEnumeration Type	Event notification selection Selection: “Action Late”, “Frame Trigger”, “Exposure Start”, “Exposure End”, “Frame Start”, “Frame End”, “Block Discard”, “Line 0 Input Rising Edge”, “Line 0 Input Falling Edge”, “Line 2 Input Rising Edge” and “Line 2 Input Falling Edge”
Event Notification	IEnumeration Type	Event notification ON / OFF selection On: Enable event notification Off: Disable event notification

10.19 Chunk Control

This function is attached additional image information to image data.

For example, the exposure time and gain information do not include in image data itself. However, Chunk data transfers these parameters when image was acquiring.

GenICam Parameters

ChunkModeActive	IBoolean Type	Chunk control ON / OFF selection Default: "False" (Off)
ChunkSelector	IEnumeration Type	Transfer Chunk data selection Selection: "Image", "Gain", "Exposure Time", "Black Level", "Line Status All", "Device Temperature", "Timer Value" and "Counter Value"
ChunkEnable	IBoolean Type	Enable Chunk data that was selected at "Chunk Selector" Selection: "True" (Enable Chunk data) and "False" (Disable Chunk data)

10.20 Action Control

The multiple cameras control by one action signal.

GenICam Parameters

ActionQueueSize	IInteger Type	Size of scheduled action command queue
ActionDeviceKey	IInteger Type	Control identifier of camera
ActionSelector	IInteger Type	Action command application selection Fixed as "0"
ActionGroupKey	IInteger Type	Action command applies camera * The camera executes action command when group key of action command and group key of camera is matched.
ActionGroupMask	IInteger Type	Select camera to apply action command Logical AND of Group Mask of camera and Group Mask of action command is 1 for any bit of 32bits, camera executes action command.

10.21 IEEE1588

Precision Time Protocol (PTP) is implemented on camera, is synchronized to “Master Clock” in same network automatically.

The camera supports IEEE 1588-2008 of PTP Version 2. The accuracy of time (Timestamp) synchronized is different based on network system configuration.

1) BMC (Best Master Clock) function

BMC function is implemented on camera. The most accurate clock in same network is defined as “Master Clock” then time (Timestamp) synchronizes. If there are more than two devices has most accurate clock in same network, clock of smallest MAC address device is defined as “Master Clock”.

2) E2E (End-to-End) Transparent Clock

The camera supports E2E method. Time difference is correcting by blow algorithm

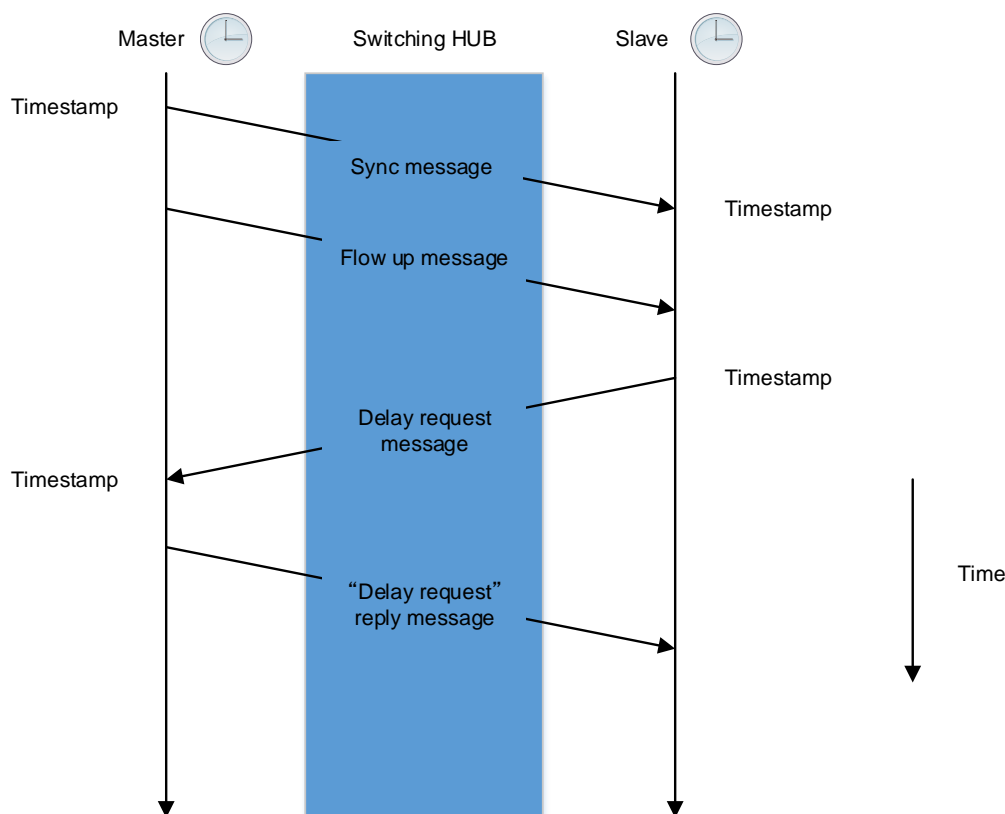

The master device and slave device exchange message included Timestamp.

Defined delay between master device and slave device by comparing these messages.

If time difference between master device and slave device is occurred, adjust internal clock of slave device to synchronize to master device.

Synchronize clock regularly to correcting time drift.

3) How to use PTP

Selects "True" at GevIEEE1588 then synchronize camera time to "Master Clock" (synchronize time is different depending on system). The camera is ready for action command after synchronize to "Master Clock".

4) Synchronized exposure for trigger mode

When action command generating, action command is broadcasting to each camera and camera starts exposing.

Synchronized exposure does not secure if action command does NOT include Timestamp. If action command includes Timestamp, action command will be scheduled automatically and each camera start exposing at same time.

Action Control setting is required when action command generating.

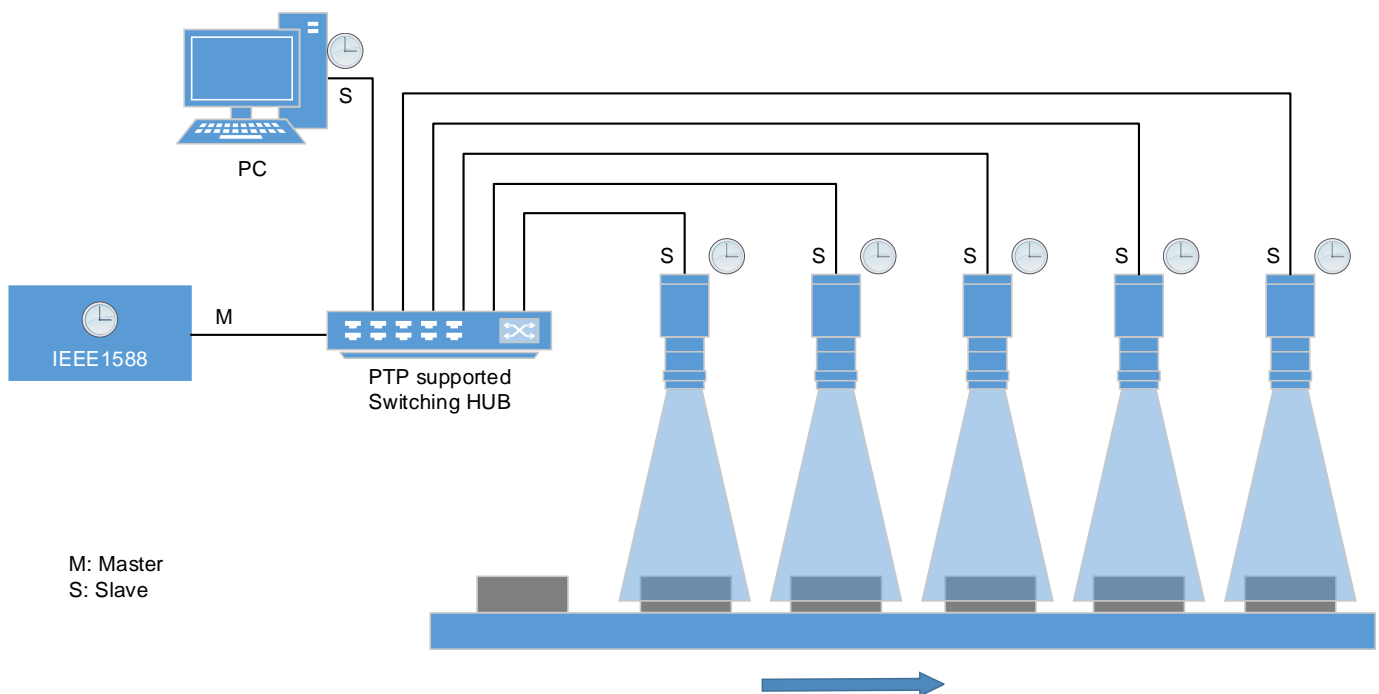

M: Master
S: Slave

e.g. PTP configuration

11 GenICam command

11.1 DeviceControl

Name	Description
DeviceType	Returns the device type.
DeviceScanType	Scan type of the sensor of the device.
DeviceVendorName	Name of the manufacturer of the device.
DeviceModelName	Model of the device.
DeviceFamilyName	Identifier of the product family of the device.
DeviceManufacturerInfo	Manufacturer information about the device.
DeviceVersion	Version of the device.
DeviceHardwareVersion	Version of the hardware in the device.
DeviceFirmwareVersion	Version of the firmware in the device.
DeviceSerialNumber	Device's serial number.
DeviceUserID	User-programmable device identifier.
DeviceSFNCVersionMajor	Major version of the Standard Features Naming Convention that was used to create the device's GenICam XML.
DeviceSFNCVersionMinor	Minor version of the Standard Features Naming Convention that was used to create the device's GenICam XML.
DeviceSFNCVersionSubMinor	Sub minor version of Standard Features Naming Convention that was used to create the device's GenICam XML.
DeviceManifestXMLMajorVersion	Indicates the major version number of the GenICam XML file of the selected manifest entry.
DeviceManifestXMLMinorVersion	Indicates the minor version number of the GenICam XML file of the selected manifest entry.
DeviceManifestXMLSubMinorVersion	Indicates the sub minor version number of the GenICam XML file of the selected manifest entry.
DeviceManifestSchemaMajorVersion	Indicates the major version number of the schema file of the selected manifest entry.
DeviceManifestSchemaMinorVersion	Indicates the minor version number of the schema file of the selected manifest entry.
DeviceTLType	Transport Layer type of the device.
DeviceTLVersionMajor	Major version of the Transport Layer of the device.
DeviceTLVersionMinor	Minor version of the Transport Layer of the device.
DeviceTLVersionSubMinor	Sub minor version of the Transport Layer of the device.
DeviceMaxThroughput	Maximum bandwidth of the data that can be streamed out of the device.
DeviceLinkSelector	Selects which Link of the device to control.
DeviceLinkSpeed [DeviceLinkSelector]	Indicates the speed of transmission negotiated on the specified Link.

Name	Description
DeviceLinkHeartbeatTimeout [DeviceLinkSelector]	Controls the current heartbeat timeout of the specific Link.
DeviceLinkCommandTimeout [DeviceLinkSelector]	Indicates the command timeout of the specified Link.
DeviceStreamChannelCount	Indicates the number of streaming channels supported by the device.
DeviceStreamChannelSelector	Selects the stream channel to control.
DeviceStreamChannelType [DeviceStreamChannelSelector]	Reports the type of the stream channel.
DeviceStreamChannelEndianness [DeviceStreamChannelSelector]	Endianness of multi-byte pixel data for this stream.
DeviceEventChannelCount	Indicates the number of event channels supported by the device.
DeviceCharacterSet	Character set used by the strings of the device's bootstrap registers.
DeviceReset	Resets the device to its power up state.
DeviceRegistersStreamingStart	Prepare the device for registers streaming without checking for consistency.
DeviceRegistersStreamingEnd	Announce the end of registers streaming.
DeviceRegistersEndianness	Endianness of the registers of the device.
DeviceTemperatureSelector	Selects the location within the device, where the temperature will be measured.
DeviceTemperature [DeviceTemperatureSelector]	Device temperature in degrees Celsius (C).
TimestampReset	Resets the current value of the device timestamp counter.
TimestampLatch	Latches the current timestamp counter into Timestamp Latch Value.
TimestampLatchValue	Returns the latched value of the timestamp counter.
DeviceUserMemory	Read / Write the user data from / to the non-volatile memory.

11.2 ImageFormatControl

Name	Description
SensorWidth	Effective width of the sensor in pixels.
SensorHeight	Effective height of the sensor in pixels.
SensorShutterMode	Sets the shutter mode of the device.
WidthMax	Maximum width of the image (in pixels).
HeightMax	Maximum height of the image (in pixels).
BinningSelector	Selects which binning engine is controlled by the Binning Horizontal and Binning Vertical features.
BinningHorizontalMode [BinningSelector]	Sets the mode to use to combine horizontal photo-sensitive cells together when Binning Horizontal is used.
BinningHorizontal [BinningSelector]	Number of horizontal photo-sensitive cells to combine together.
BinningVertical [BinningSelector]	Number of vertical photo-sensitive cells to combine together.
DecimationHorizontal	Horizontal sub-sampling of the image.
DecimationVertical	Vertical sub-sampling of the image.
RegionSelector	Selects the Region of interest to control.
RegionMode [RegionSelector]	Controls if the selected Region of interest is active and streaming.
Width [RegionSelector]	Width of the image provided by the device (in pixels).
Height [RegionSelector]	Height of the image provided by the device (in pixels).
OffsetX [RegionSelector]	Horizontal offset from the origin to the region of interest (in pixels).
OffsetY [RegionSelector]	Vertical offset from the origin to the region of interest (in pixels).
PixelFormat	Format of the pixels provided by the device.
PixelSize	Total size in bits of a pixel of the image.
PixelColorFilter	Type of color filter that is applied to the image.
ReverseY	Flip vertically the image sent by the device.
TestPatternGeneratorSelector	Selects which test pattern generator is controlled by the Test Pattern feature.
TestPattern [TestPatternGeneratorSelector]	Selects the type of test pattern that is generated by the device as image source.
TestPatternInputValue [TestPatternGeneratorSelector]	Test Pattern Input Value

11.3 AcquisitionControl

Name	Description
AcquisitionMode	Sets the acquisition mode of the device.
AcquisitionStart	Starts the Acquisition of the device.
AcquisitionStop	Stops the Acquisition of the device at the end of the current Frame.
AcquisitionFrameCount	Number of frames to acquire in Multi Frame Acquisition mode.
AcquisitionFrameRate	Controls the acquisition rate (in Hertz) at which the frames are captured.
TriggerSelector	Selects the type of trigger to configure.
TriggerMode [TriggerSelector]	Controls if the selected trigger is active.
TriggerSoftware [TriggerSelector]	Generates an internal trigger.
TriggerSource [TriggerSelector]	Specifies the internal signal or physical input Line to use as the trigger source.
TriggerActivation [TriggerSelector]	Specifies the activation mode of the trigger.
TriggerDelay [TriggerSelector]	Specifies the delay in microseconds (us) to apply after the trigger reception before activating it.
ExposureMode	Sets the operation mode of the Exposure.
ExposureTimeSelector	Selects which exposure time is controlled by the Exposure Time feature.
ExposureTime [ExposureTimeSelector]	Sets the Exposure time when Exposure Mode is Timed and Exposure Auto is Off.
ExposureAuto	Sets the automatic exposure mode when Exposure Mode is Timed.
ExposureAutoLimitMin	Determine the lower limit of exposure time when Exposure Auto is set to Continuous.
ExposureAutoLimitMax	Determine the upper limit of exposure time when Exposure Auto is set to Continuous.

11.4 AnalogControl

Name	Description
GainSelector	Selects which Gain is controlled by the various Gain features.
Gain [GainSelector]	Controls the selected gain as an absolute physical value.
GainAuto [GainSelector]	Sets the automatic gain control (AGC) mode.
GainAutoLimitMin [GainSelector]	Determine the lower limit of gain when Gain Auto is set to Continuous.
GainAutoLimitMax [GainSelector]	Determine the upper limit of gain when Gain Auto is set to Continuous.
AutoLuminanceTarget	Target brightness for auto luminance control.
AutoLuminanceRegionSelector	Select the area for auto luminance control.
AutoLuminanceWidth [AutoLuminanceRegionSelector]	Determine width of targeted region for auto luminance control.
AutoLuminanceHeight [AutoLuminanceRegionSelector]	Determine height of targeted region for auto luminance control.
AutoLuminanceOffsetX [AutoLuminanceRegionSelector]	Determine X offset of targeted region for auto luminance control.
AutoLuminanceOffsetY [AutoLuminanceRegionSelector]	Determine Y offset of targeted region for auto luminance control.
AutoLuminanceWeight [AutoLuminanceRegionSelector]	Weight of the area determined by Auto Luminance Region Selector for auto luminance control.
AutoLuminancePeak	Ratio of peak and average for auto luminance control.
BlackLevelSelector	Selects which Black Level is controlled by the various Black Level features.
BlackLevel [BlackLevelSelector]	Controls the analog black level as an absolute physical value.
DigitalGainOffsetMode	Digital Gain Offset Mode is enabled.
BalanceRatioSelector	Selects which Balance ratio to control. (STC-MCA503POE)
BalanceRatio [BalanceRatioSelector]	Controls ratio of the selected color component to a reference color component. (STC-MCA503POE)
BalanceWhiteAuto	Controls the mode for automatic white balancing between the color channels. (STC-MCA503POE)
BalanceWhiteAutoRegionSelector	Select the area for auto white balance. (STC-MCA503POE)
BalanceWhiteAutoWidth [BalanceWhiteAutoRegionSelector]	Determine width of targeted region for auto white balance. (STC-MCA503POE)
BalanceWhiteAutoHeight [BalanceWhiteAutoRegionSelector]	Determine height of targeted region for auto white balance. (STC-MCA503POE)
BalanceWhiteAutoOffsetX [BalanceWhiteAuto RegionSelector]	Determine X offset of targeted region for auto white balance. (STC-MCA503POE)
BalanceWhiteAutoOffsetY [BalanceWhiteAutoRegionSelector]	Determine Y offset of targeted region for auto white balance. (STC-MCA503POE)
Gamma	Controls the gamma correction of pixel intensity.

11.5 LUTControl

Name	Description
LUTSelector	Selects which LUT to control.
LUTEnable [LUTSelector]	Activates the selected LUT.
LUTIndex [LUTSelector]	Control the index (offset) of the coefficient to access in the selected LUT.
LUTValue [LUTSelector] [LUTIndex]	Returns the Value at entry LUT Index of the LUT selected by LUT Selector.
LUTValueAll [LUTSelector]	Accesses all the LUT coefficients in a single access without using individual LUT Index.
PixelCorrectionAllEnabled	Enable pixel correction for all pixels.
PixelCorrectionIndex	Determine index of targeted pixel for pixel correction.
PixelCorrectionEnabled [PixelCorrectionIndex]	Determine if targeted pixel is enabled for pixel correction.
PixelCorrectionX [PixelCorrectionIndex]	Determine x-coordinate of targeted pixel for pixel correction.
PixelCorrectionY [PixelCorrectionIndex]	Determine y-coordinate of targeted pixel for pixel correction.

11.6 DigitalIOControl

Name	Description
LineSelector	Selects the physical line (or pin) of the external device connector or the virtual line of the Transport Layer to configure.
LineMode [LineSelector]	Controls if the physical Line is used to Input or Output a signal.
LineFormat [LineSelector]	Controls the current electrical format of the selected physical input or output Line.
LineSource [LineSelector]	Selects which internal acquisition or I/O source signal to output on the selected Line.
LineInverter [LineSelector]	Controls the inversion of the signal of the selected input or output Line.
LineDebounceTime [LineSelector]	Sets the value of the input line debouncer time.
LineStatus [LineSelector]	Returns the current status of the selected input or output Line.
LineStatusAll	Returns the current status of all available Line signals at time of polling in a single bitfield.
UseOutputSelector	Selects which bit of the User Output register will be set by User Output Value.
UseOutputValue [UseOutputSelector]	Sets the value of the bit selected by User Output Selector.

11.7 LogicBlockControl

Name	Description
LogicBlockSelector	Specifies the Logic Block to configure.
LogicBlockFunction [LogicBlockSelector]	Selects the combinational logic Function of the Logic Block to configure.
LogicBlockInputNumber [LogicBlockSelector]	Specifies the number of active signal inputs of the Logic Block.
LogicBlockInputSelector [LogicBlockSelector]	Selects the Logic Block's input to configure.
LogicBlockInputSource [LogicBlockSelector] [LogicBlockInputSelector]	Selects the source signal for the input into the Logic Block.
LogicBlockInputInverter [LogicBlockSelector] [LogicBlockInputSelector]	Selects if the selected Logic Block Input source signal is inverted.

11.8 SoftwareSignalControl

Name	Description
SoftwareSignalSelector	Selects which Software Signal features to control.
SoftwareSignalPulse [SoftwareSignalSelector]	Generates a pulse signal that can be used as a software trigger.

11.9 CounterAndTimerControl

Name	Description
CounterSelector	Selects which Counter to configure.
CounterEventSource [CounterSelector]	Select the events that will be the source to increment the Counter.
CounterResetSource [CounterSelector]	Selects the signals that will be the source to reset the Counter.
CounterResetActivation [CounterSelector]	Selects the Activation mode of the Counter Reset Source signal.
CounterReset [CounterSelector]	Does a software reset of the selected Counter and starts it.
CounterValue [CounterSelector]	Reads or writes the current value of the selected Counter.
TimerSelector	Selects which Timer to configure.
TimerDuration [TimerSelector]	Sets the duration (in microseconds) of the Timer pulse.
TimerDelay [TimerSelector]	Sets the duration (in microseconds) of the delay to apply at the reception of a trigger before starting the Timer.
TimerTriggerSource [TimerSelector]	Selects the source of the trigger to start the Timer.
TimerTriggerActivation [TimerSelector]	Selects the activation mode of the trigger to start the Timer.
TimerValue [TimerSelector]	Reads or writes the current value (in microseconds) of the selected Timer.

11.10 EventControl

Name	Description
EventSelector	Selects which Event to signal to the host application.
EventNotification [EventSelector]	Activate or deactivate the notification to the host application of the occurrence of the selected Event.
EventTestData	Category that contains all the data features related to the Event Test generated using the Test Event Generate command.
EventExposureStartData	Category that contains all the data features related to the Exposure Start Event.
EventExposureEndData	Category that contains all the data features related to the Exposure End Event.
EventFrameTriggerData	Category that contains all the data features related to the Frame Trigger Event.
EventFrameStartData	Category that contains all the data features related to the Frame Start Event.
EventFrameEndData	Category that contains all the data features related to the Frame End Event.
EventLine0RisingEdgeData	Category that contains all the data features related to the Line0 Rising Edge Event.
EventLine0FallingEdgeData	Category that contains all the data features related to the Line0 Falling Edge Event.
EventLine2RisingEdgeData	Category that contains all the data features related to the Line2 Rising Edge Event.
EventLine2FallingEdgeData	Category that contains all the data features related to the Line2 Falling Edge Event.
EventBlockDiscardData	Category that contains all the data features related to the Block Discard Event.
EventActionLateData	Category that contains all the data features related to the Action Late Event.

11.11 UserSetControl

Name	Description
UserSetSelector	Selects the feature User Set to load, save or configure.
UserSetLoad [UserSetSelector]	Loads the User Set specified by User Set Selector to the device and makes it active.
UserSetSave [UserSetSelector]	Save the User Set specified by User Set Selector to the non-volatile memory of the device.
UserSetDefault	Selects the feature User Set to load and make active by default when the device is reset.

11.12 ChunkDataControl

Name	Description
ChunkModeActive	Activates the inclusion of Chunk data in the payload of the image.
ChunkSelector	Selects which Chunk to enable or control.
ChunkEnable [ChunkSelector]	Enables the inclusion of the selected Chunk data in the payload of the image.
ChunkCounterSelector	Selects which counter to retrieve data from.
ChunkCounterValue [ChunkCounterSelector]	Returns the value of the selected Chunk counter.
ChunkGainSelector	Selects which Gain to return.
ChunkGain [ChunkGainSelector]	Returns the gain used to capture the image.
ChunkExposureTimeSelector	Selects which Exposure Time to return.
ChunkExposureTime [ChunkExposureTimeSelector]	Returns the exposure time used to capture the image.
ChunkBlackLevelSelector	Selects which Black Level to return.
ChunkBlackLevel [ChunkBlackLevelSelector]	Returns the black level used to capture the image included in the payload.
ChunkLineStatusAll	Returns the status of all the I/O lines at the time of the Frame Start internal event.
ChunkTimerSelector	Selects which timer to retrieve data from.
ChunkTimerValue [ChunkTimerSelector]	Returns the value of the selected Timer.
ChunkDeviceTemperature	Indicates the value of the temperature when the image was acquired.

11.13 ActionControl

Name	Description
ActionDeviceKey	Provides the device key that allows the device to check the validity of action commands.
ActionQueueSize	Indicates the size of the scheduled action commands queue.
ActionSelector	Selects to which Action Signal further Action settings apply.
ActionGroupMask [ActionSelector]	Provides the mask that the device will use to validate the action on reception of the action protocol message.
ActionGroupKey [ActionSelector]	Provides the key that the device will use to validate the action on reception of the action protocol message.

11.14 File AccessControl

Name	Description
FileSelector	Selects the target file in the device.
FileOperationSelector [FileSelector]	Selects the target operation for the selected file in the device.
FileOperationExecute [FileSelector] [FileOperationSelector]	Executes the operation selected by File Operation Selector on the selected file.
FileOpenMode [FileSelector]	Selects the access mode in which a file is opened in the device.
FileAccessBuffer	Defines the intermediate access buffer that allows the exchange of data between the device file storage and the application.
FileAccessOffset [FileSelector] [FileOperationSelector]	Controls the Offset of the mapping between the device file storage and the File Access Buffer.
FileAccessLength [FileSelector] [FileOperationSelector]	Controls the Length of the mapping between the device file storage and the File Access Buffer
FileOperationStatus [FileSelector] [FileOperationSelector]	Represents the file operation execution status.
FileOperationResult [FileSelector] [FileOperationSelector]	Represents the file operation result.
FileSize [FileSelector]	Represents the size of the selected file in bytes.

11.15 TestControl

Name	Description
TestPendingAck	Tests the device's pending acknowledge feature.
TestEventGenerate	Generates a Test Event.

11.16 TransportLayerControl

Name	Description
PayloadSize	Provides the number of bytes transferred for each image or chunk on the stream channel.
PtpEnable	Enable the Precision Time Protocol (PTP).
PtpClockAccuracy	Indicate the expected accuracy of the device PTP clock when it is the grandmaster, or in the event it becomes the grandmaster.
PtpDataSetLatch	Latches the current values from the device's PTP clock data set.
PtpStatus	Returns the latched state of the PTP clock.
PtpOffsetFromMaster	The latched offset from the PTP master clock in nanoseconds.
PtpClockID	The latched clock ID of the PTP device. PTP Parent Clock ID.
PtpParentClockID	The latched parent clock ID of the PTP device. The parent clock ID is the clock ID of the current master clock.
PtpGrandmasterClockID	The latched grandmaster clock ID of the PTP device. The grandmaster clock ID is the clock ID of the current grandmaster clock.
GevSupportedOptionSelector	Selects the GEV option to interrogate for existing support.
GevSupportedOption [GevSupportedOptionSelector]	Returns if the selected GEV option is supported.
GevInterfaceSelector	Selects which logical link to control.
GevMACAddress [GevInterfaceSelector]	MAC address of the logical link.
GevCurrentIPConfigurationLLA [GevInterfaceSelector]	Controls whether the Link Local Address IP configuration scheme is activated on the given logical link.
GevCurrentIPConfigurationDHCP [GevInterfaceSelector]	Controls whether the DHCP IP configuration scheme is activated on the given logical link.
GevCurrentIPConfigurationPersistentIP [GevInterfaceSelector]	Controls whether the Persistent IP configuration scheme is activated on the given logical link.
GevCurrentIPAddress [GevInterfaceSelector]	Reports the IP address for the given logical link.
GevCurrentSubnetMask [GevInterfaceSelector]	Reports the subnet mask of the given logical link.
GevCurrentDefaultGateway [GevInterfaceSelector]	Reports the default gateway IP address to be used on the given logical link.
GevIPConfigurationStatus [GevInterfaceSelector]	Reports the current IP configuration status.
GevPersistentIPAddress [GevInterfaceSelector]	Controls the Persistent IP address for this logical link.
GevPersistentSubnetMask [GevInterfaceSelector]	Controls the Persistent subnet mask associated with the Persistent IP address on this logical link.
GevPersistentDefaultGateway [GevInterfaceSelector]	Controls the persistent default gateway for this logical link.
GevGVCPExtendedStatusCodesSelector	Selects the GigE Vision version to control extended status codes for.

Name	Description
GevGVCPExtendedStatusCodes [GevGVCPExtendedStatusCodesSelector]	Enables the generation of extended status codes.
GevGVCPPendingAck	Enables the generation of PENDING_ACK.
GevPrimaryApplicationSwitchoverKey	Controls the key to use to authenticate primary application switchover requests.
GevGVCPExpendedIDMode	Enables the extended IDs mode.
GevCCP	Controls the device access privilege of an application.
GevPrimaryApplicationSocket	Returns the UDP source port of the primary application.
GevPrimaryApplicationIPAddress	Returns the address of the primary application.
GevMCPHostPort	Controls the port to which the device must send messages.
GevMCDA	Controls the destination IP address for the message channel.
GevMCTT	Provides the transmission timeout value in milliseconds.
GevMCRC	Controls the number of retransmissions allowed when a message channel message times out.
GevMCSP	This feature indicates the source port for the message channel.
GevStreamChannelSelector	Selects the stream channel to control.
GevSCPInterfaceIndex [GevStreamChannelSelector]	Index of the logical link to use.
GevSCPHostPort [GevStreamChannelSelector]	Controls the port of the selected channel to which a GVSP transmitter must send data stream or the port from which a GVSP receiver may receive data stream.
GevSCPSFireTestPacket [GevStreamChannelSelector]	Sends a test packet.
GevSCPSDoNotFragment [GevStreamChannelSelector]	The state of this feature is copied into the "do not fragment" bit of IP header of each stream packet.
GevSCPSPacketSize [GevStreamChannelSelector]	This GigE Vision specific feature corresponds to DeviceStreamChannelPacketSize and should be kept in sync with it.
GevSCFTD [GevStreamChannelSelector]	Controls the delay (in GEV timestamp counter unit) to insert between each packet for this stream channel.
GevSCPD [GevStreamChannelSelector]	Controls the delay (in GEV timestamp counter unit) to insert between each frame for this stream channel.
GevSCDA [GevStreamChannelSelector]	Controls the destination IP address of the selected stream channel to which a GVSP transmitter must send data stream or the destination IP address from which a GVSP receiver may receive data stream.
GevSCSP [GevStreamChannelSelector]	Indicates the source port of the stream channel.

12 Revision History

Rev	Date	Changes	Note
00	2019/05/31	● New Document	
01	2019/06/07	● Revised Added "LWIP TCP/IP Licensing" information	
02	2019/09/25	● Revised Change the resistance value of the Opto-isolated output circuit in the camera	

Note: Product specifications would be changed without notification.

GigE Vision is trademark of AIA.

GenICam is trademark of EMVA.

Other company names and product names in this document are trademarks of their respective owners.

OMRON SENTECH CO., LTD.

19F, Ebina Prime Tower
9-50, Chuo 2 chome
Ebina-city, Kanagawa
243-0432 Japan
TEL 81-46-236-6660 FAX 81-46-236-6661
URL <http://www.sentech.co.jp/>