

## Enterprise Manager 2100

### User's Guide



## Copyright Notice

---

The information contained herein is the property of Omron Adept Technologies, Inc., and shall not be reproduced in whole or in part without prior written approval of Omron Adept Technologies, Inc. The information herein is subject to change without notice and should not be construed as a commitment by Omron Adept Technologies, Inc. The documentation is periodically reviewed and revised.

Omron Adept Technologies, Inc., assumes no responsibility for any errors or omissions in the documentation. Critical evaluation of the documentation by the user is welcomed. Your comments assist us in preparation of future documentation. Please submit your comments to: [tech-pubs@adept.com](mailto:tech-pubs@adept.com).

Copyright © 2018 by Omron Adept Technologies, Inc. All rights reserved.

Any trademarks from other companies used in this publication  
are the property of those respective companies.

Created in the United States of America

# Table of Contents

---

|  |           |
|--|-----------|
| <b>Chapter 1: Introduction to the Enterprise Manager 2100</b> .....  | <b>7</b>  |
| 1.1 Description of the Enterprise Manager 2100 .....                 | 7         |
| 1.2 Number of AIVs Supported by an Enterprise Manager 2100 .....     | 9         |
| The Workspace Map .....  | 9         |
| Robot Jobs .....   | 10        |
| Communications Network .....   | 10        |
| 1.3 Hardware Supplied with the Enterprise Manager 2100 .....         | 10        |
| Optional Equipment .....   | 11        |
| Equipment Not Provided with an Enterprise Manager 2100 .....         | 11        |
| 1.4 Features of the Enterprise Manager 2100 .....                    | 11        |
| 1.5 Software Supplied with the Enterprise Manager 2100 Systems ..... | 12        |
| SetNetGo Operating System 4.9.x .....                                | 12        |
| Mobile Robot Software Suite Version 4.9.x .....                      | 12        |
| MobilePlanner in Fully Licensed Mode .....                           | 13        |
| MobilePlanner in Operator Mode .....                                 | 13        |
| ARAM .....   | 13        |
| ARAMCentral .....  | 13        |
| ARCL Protocol .....  | 14        |
| Mobile Adept Robot Controller (MARC) .....                           | 14        |
| Peripheral Devices .....   | 14        |
| 1.6 Supported Enterprise Manager 2100 Deployments .....              | 14        |
| Enterprise Manager 2100 Autosync Failure Scenarios .....             | 15        |
| 1.7 How to Get Help .....  | 15        |
| Related Manuals .....  | 15        |
| Service and Support .....  | 16        |
| <b>Chapter 2: Safety</b> .....                                       | <b>17</b> |
| 2.1 Alert Levels .....   | 17        |
| Alert Icons .....  | 18        |
| Special Information .....  | 18        |
| 2.2 Safety Precautions for the Enterprise Manager 2100 .....         | 19        |
| General Hazards .....  | 19        |
| Additional Safety Information .....                                  | 20        |
| 2.3 Disposal .....   | 20        |
| <b>Chapter 3: Installation</b> .....                                 | <b>21</b> |
| 3.1 Prepare Your Site for the Enterprise Manager 2100 .....          | 21        |
| Site Rack Requirements .....   | 21        |

|   |           |
|---|-----------|
| Site Electrical Power Requirements .....                              | 22        |
| Electrical Wiring .....   | 22        |
| Site Networking Requirements .....                                    | 23        |
| Local Area Network (LAN) Requirements .....                           | 23        |
| Wireless Network Requirements .....                                   | 23        |
| 3.2 Transport and Storage of the Enterprise Manager 2100 .....        | 23        |
| 3.3 Unpack the Shipment .....   | 24        |
| Before You Unpack the Enterprise Manager 2100 .....                   | 24        |
| Unpack the Enterprise Manager 2100 Shipping Carton .....              | 24        |
| 3.4 Sliding Rail Kit for Rack Mounting .....                          | 25        |
| Components in the Sliding Rail Kit .....                              | 27        |
| Tools Required to Install the Sliding Rail Kit .....                  | 27        |
| Determine the Sliding Rail Kit Installation Location and Method ..... | 29        |
| Remove the Sliding Rail from the Track .....                          | 29        |
| Attach the Sliding Rail to the Chassis .....                          | 29        |
| Attach the Adjustable Brackets to the Track .....                     | 30        |
| Determine the Mounting Method for the Sliding Rail Kit .....          | 31        |
| Attach the Track to the Rack Posts .....                              | 31        |
| Adjust the Track to Span the Rack Posts .....                         | 31        |
| Attach the Track to the Rack Posts .....                              | 32        |
| Insert the Appliance Into the Track .....                             | 33        |
| 3.5 Connect Power to the Enterprise Manager 2100 .....                | 33        |
| 3.6 Plan for Disaster Tolerance .....                                 | 34        |
| 3.7 Installing a Secondary Appliance .....                            | 34        |
| <b>Chapter 4: Connectors and Indicators .....</b>                     | <b>37</b> |
| 4.1 Overview of the Enterprise Manager 2100 .....                     | 37        |
| 4.2 Rear Panel Connectors and Features .....                          | 38        |
| 4.3 Enterprise Manager 2100 Status Display Panel .....                | 39        |
| Autosync Status .....   | 39        |
| 4.4 Connect the Enterprise Manager 2100 to a Network .....            | 40        |
| Logical Ports and Protocols Used by the Enterprise Manager 2100 ..... | 42        |
| Logical Ports and Protocols Used by a Single AIV .....                | 43        |
| <b>Chapter 5: Configuration .....</b>                                 | <b>45</b> |
| 5.1 Enterprise Manager 2100 Configuration Overview .....              | 45        |
| Ethernet Connections .....  | 45        |
| Configuration Tasks Overview .....                                    | 46        |
| 5.2 Set the IP Address on a Client PC's Network Adapter .....         | 47        |
| 5.3 Connect Your PC to SetNetGo on the Enterprise Manager 2100 .....  | 47        |
| Connect to SetNetGo and Configure Access and Security .....           | 47        |
| Enable Fleet Account Access .....                                     | 48        |
| Access SetNetGo from Mobile Planner .....                             | 48        |

|                                   |   |           |
|-----------------------------------|---|-----------|
| 5.4                               | Configure Management Interface Network Settings .....                     | 49        |
| 5.5                               | Configure the Fleet Interface Network Settings .....                      | 50        |
| 5.6                               | Use NTP to Synchronize Enterprise Manager 2100 Time .....                 | 51        |
| 5.7                               | Enabling the ARCL Server .....  | 52        |
| 5.8                               | Configure Each AIV to Connect to the Enterprise Manager .....             | 52        |
|                                   | AIV Configuration Settings .....  | 52        |
|                                   | Fleet-Level Settings .....  | 53        |
| 5.9                               | Add a Secondary Appliance for AutoSync .....                              | 54        |
| 5.10                              | Configure a Secondary Appliance and Autosync .....                        | 54        |
|                                   | EM2100-Only Autosync – Ethernet Cabling .....                             | 55        |
|                                   | EM2100 and EM1100 Autosync – Ethernet Cabling .....                       | 55        |
|                                   | Tasks in Autosync Setup .....   | 56        |
|                                   | Configure the Primary Appliance .....                                     | 56        |
|                                   | Configure the Secondary Appliance .....                                   | 57        |
| 5.11                              | Customize Each Fleet AIV .....  | 57        |
|                                   | Docking Station Assignment .....  | 57        |
|                                   | Default Mode .....  | 58        |
|                                   | Mixed Mode .....  | 58        |
|                                   | Separate Docking Stations .....   | 58        |
|                                   | Distinct Speech Synthesis Voices .....                                    | 58        |
| 5.12                              | Call Buttons .....  | 59        |
| <b>Chapter 6: Operation .....</b> |   | <b>61</b> |
| 6.1                               | Turn Enterprise Manager 2100 Power ON and OFF .....                       | 61        |
|                                   | Safe Power On .....   | 61        |
|                                   | Soft Shutdown and Power Off .....   | 61        |
|                                   | Hard Shutdown and Power Off .....   | 62        |
|                                   | Power On After a Hard Shutdown .....                                      | 62        |
|                                   | Affect of Power Interruptions on an Enterprise Manager 2100 .....         | 62        |
|                                   | Power Interruptions on a Standalone Enterprise Manager 2100 .....         | 62        |
|                                   | Power Interruptions on an Autosync Enterprise Manager 2100 .....          | 63        |
| 6.2                               | Generate a Workspace Map for Your Fleet .....                             | 64        |
| 6.3                               | Managing Queuing .....  | 64        |
|                                   | Queuing and Job Definitions .....   | 64        |
|                                   | Queuing Examples .....  | 66        |
|                                   | Queuing Parameters .....  | 68        |
|                                   | Manually Clearing (Flushing) the Entire Queue .....                       | 70        |
| 6.4                               | Update the ARAMCentral Software .....                                     | 71        |
|                                   | Restarting ARAMCentral .....  | 71        |
| 6.5                               | Enterprise Manager 2100 Autosync Operation .....                          | 71        |
| 6.6                               | Remove and Replace Enterprise Manager 2100 Appliances from Autosync ..... | 72        |
|                                   | Remove a Primary Appliance from Autosync .....                            | 72        |
|                                   | Remove a Secondary Appliance from Autosync .....                          | 73        |

|  |           |
|--|-----------|
| 6.7 What to do if an EM2100 Primary Appliance Fails .....  | 74        |
| 6.8 What to do if an EM1100 Autosync Appliance Fails ..... | 74        |
| Configure an EM1100 to EM2100 Configuration .....          | 74        |
| 6.9 Troubleshooting .....                                  | 76        |
| Including a debugInfo File with Your Help Request .....    | 77        |
| <b>Chapter 7: Technical Specifications .....</b>           | <b>79</b> |
| 7.1 Processing Specifications .....                        | 79        |
| 7.2 Environmental Specifications .....                     | 79        |
| 7.3 Power Requirements .....                               | 79        |
| 7.4 Physical Characteristics .....                         | 80        |
| 7.5 Connections .....                                      | 81        |
| Front .....  | 81        |
| Rear .....   | 81        |

# Chapter 1: Introduction to the Enterprise Manager 2100

---

This chapter provides a description of the Enterprise Manager 2100. It includes the following topics.

|  |    |
|--|----|
| <a href="#">1.1 Description of the Enterprise Manager 2100</a>                 | 7  |
| <a href="#">1.2 Number of AIVs Supported by an Enterprise Manager 2100</a>     | 9  |
| <a href="#">1.3 Hardware Supplied with the Enterprise Manager 2100</a>         | 10 |
| <a href="#">1.4 Features of the Enterprise Manager 2100</a>                    | 11 |
| <a href="#">1.5 Software Supplied with the Enterprise Manager 2100 Systems</a> | 12 |
| <a href="#">1.6 Supported Enterprise Manager 2100 Deployments</a>              | 14 |
| <a href="#">1.7 How to Get Help</a>  | 15 |

## 1.1 Description of the Enterprise Manager 2100

The Enterprise Manager 2100 is a hardware and software solution that enables you to manage a fleet of Automated Intelligent Vehicles (AIVs, also called *robots* in the software and documentation). The Enterprise Manager appliance uses a *queuing manager* software feature to communicate with AIVs in the fleet. It receives and processes job requests from users, call buttons, and automation equipment. It then assigns jobs to appropriate AIVs in the fleet.

Different groups of AIVs in a fleet might require the same configuration depending on their physical characteristics or task activities. Maintaining identical configurations on each group of AIVs is time-consuming and error-prone. The Enterprise Manager 2100 enables you to manage both map and configuration updates for every AIV in the fleet from a single point of access.

The Enterprise Manager 2100 also coordinates the movement and interaction of up to 100 AIVs in a fleet, to make sure that each AIV knows the location and path of any other AIV that might affect it. This enables AIVs to work efficiently within close range of each other without risk of collision or of interfering with each other's movements and operations.

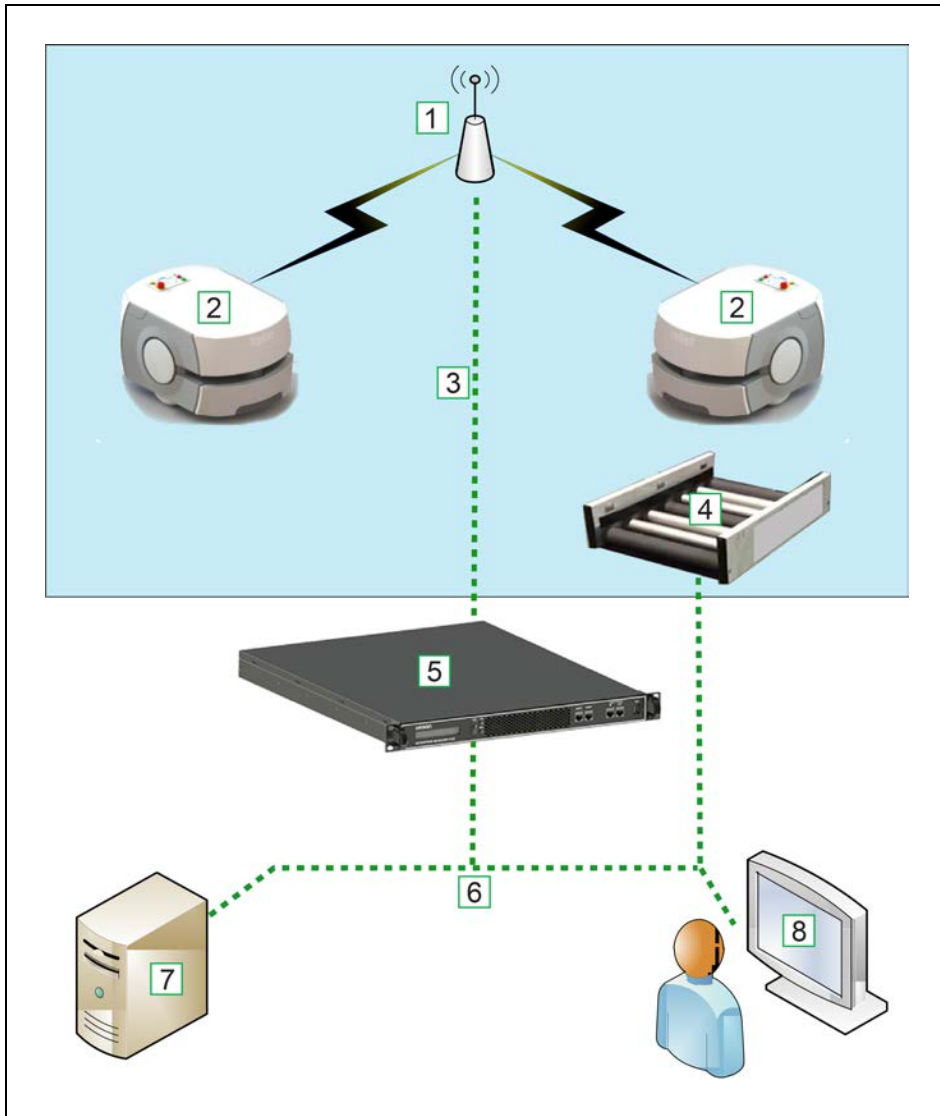

Figure 1-1. Main Components of an Enterprise Manager 2100 Installation

A typical installation is shown in Figure 1-1. The operator’s terminal, automated factory equipment, and WMS or MES systems all communicate directly with the Enterprise Manager 2100.

Table 1-1. Description of the Main Components in an Enterprise Manager 2100 Installation

| Callout | Description  |
|---------|--|
| 1       | 802.11a/b/g WiFi access point.   |
| 2       | AIVs configured to connect to the Enterprise Manager Fleet IP address. |
| 3       | Local Area Network (LAN).  |
| 4       | Automated factory equipment such as a conveyor.                        |
| 5       | Enterprise Manager 2100 running Mobile Robot software components.      |



| Callout  | Description   |
|----------|---|
| <b>6</b> | Connection to the Ethernet port on the Enterprise Manager 2100  |
| <b>7</b> | Operations management and control software such as a warehouse management system (WMS) or manufacturing execution system (MES). |
| <b>8</b> | Operator's terminal, running the MobilePlanner software.  |



Figure 1-2. Enterprise Manager 2100 Appliance

## 1.2 Number of AIVs Supported by an Enterprise Manager 2100

The software license for a single Enterprise Manager 2100 supports an absolute limit of 100 AIVs. The actual number of AIVs that you can manage effectively is subject to practical operational constraints. Each robot consumes computing and communication resources. The more complicated and dynamic the environment, the more resources an individual AIV consumes.

The following considerations apply when planning for the number of AIVs that your appliance can support.

### The Workspace Map

Your Enterprise Manager 2100 can support more AIVs if the characteristics of your workspace map are as follows:

- The map is relatively small and well-defined with adequate physical features to facilitate autonomous navigation. Taking time to refine your map enables your EM2100 to support a larger number of AIVs.
- The area where AIVs operate is static, and workspace map features have greater permanence. If the workspace changes constantly and contains many temporary or moving obstacles (such as fork-lift trucks and people) then your EM2100 can support fewer AIVs.
- There is minimal interaction between AIVs at goals or choke points such as doors and corridors.

Using path planning map features (such as preferred lines) to organize and segregate AIVs can increase the potential number of supported AIVs.

**NOTE:** Certain Mobile Software suite tuning parameters (such as **PlanRes**) might have a negative effect on the number of supported AIVs. Before tuning any configuration parameters discuss your objectives with an Omron representative.

### Robot Jobs

Your Enterprise Manager 2100 can support more AIVs if the job characteristics are as follows:

- AIV job routes are not complicated by many sub-tasks.
- Interaction with a Warehouse Management System (WMS) or Manufacturing Execution System (MES) is relatively simple and automated.
- There is minimal use of payload devices and interaction with automated devices such as conveyors.
- AIVs are not competing for limited resources such as goals or docking stations.
- Jobs use FIFO queuing instead of non-FIFO queuing.

### Communications Network

Your Enterprise Manager 2100 can support more AIVs if the network characteristics are as follows:

- Dedicated, high-speed network with adequate per-robot wireless bandwidth.
- Good access point coverage with few or no low-signal (shadow) locations.
- Network (LAN and Wireless) provides a good quality of service (QoS) to the Enterprise Manager software.

If you have any questions when planning the number of AIVs for an enterprise, contact your local Omron sales office for assistance.

## 1.3 Hardware Supplied with the Enterprise Manager 2100

The Enterprise Manager 2100 is a *computing appliance* with a processor capable of running the Mobile Robot Software Suite. It has the ability to connect to, communicate with, and control the AIV fleet and its operation.

The Enterprise Manager appliance includes:

- Intel® Xeon® CPU
- 32 GB RAM
- 4 TB of storage
- Enterprise Manager license (installed internally)
- All of the connectors listed in Connectors and Indicators on page 37
- Rack-mount rails for a four-post data center rack
- Power cable set, including cables for use in various locales world-wide

## Optional Equipment

You can add a Secondary Enterprise Manager appliance, to provide redundancy for the Primary appliance.

After you install a Secondary appliance, configure it to auto-synchronize with the Primary to enable faster recovery of your AIV fleet operations should the Primary appliance fail for any reason. The Secondary appliance contains a copy of the fleet data, including current jobs and maps.

## Equipment Not Provided with an Enterprise Manager 2100

You must provide the following:

- A consistent power supply. Omron Adept Technologies, Inc. recommends that you use an uninterruptible power supply (UPS). Contact your local Omron support for more information.
- Network infrastructure necessary for communication and optionally for redundant network communication when you use an optional Secondary appliance.
- Omron Adept Technologies, Inc. Automated Intelligent Vehicles (AIVs), also known as mobile robots.
- Client computer - Compatible Windows PC clients to run MobilePlanner for remote access to the appliance and AIVs. Each MobilePlanner instance requires a license key for full operation.

## 1.4 Features of the Enterprise Manager 2100

Key features of the Enterprise Manager 2100 and the Mobile Robot Software Suite, running on the Enterprise Manager appliance are:

- Provides the ability to manage the configuration settings for an entire fleet of AIVs.

Each AIV obtains configuration data from the Enterprise Manager appliance, saving you time and making configuration updates more reliable.

- Optimizes traffic flow

The Enterprise Manager appliance shares each AIV's position and movement with other AIVs in its vicinity. This enables each AIV to make dynamic route adjustments to avoid potential conflicts.

- Provides Queuing Manager functionality.

The Enterprise Manager appliance receives job requests from call buttons and factory equipment management systems (WMS or MES), makes decisions about which job an AIV receives, and provides real-time job status updates to connected automation equipment.

- Economical use of wireless network bandwidth.

Each AIV exchanges information only with the Enterprise Manager appliance, rather than communicating with every individual AIV.

- Serves as a proxy for AIV status data, such as location, battery, and job.

This reduces the consumption of wireless bandwidth and enables all AIVs in a fleet to connect to one central point. You can monitor all AIVs from a single application.

- Low maintenance

The Enterprise Manager 2100 functions as an appliance, not a server. It runs reliably with little human intervention and minimal maintenance by IT staff. It is dedicated only to the task of robot fleet management and is unaffected by other services. If something happens to the appliance, you can replace it, recreate the configuration on the replacement appliance and the replacement operates identically.

You can optionally configure an additional (redundant) Secondary appliance for faster recovery if the Primary appliance fails for any reason. See *Add a Secondary Appliance for AutoSync* on page 54.

## 1.5 Software Supplied with the Enterprise Manager 2100 Systems

Your Enterprise Manager 2100 shipment includes a USB drive containing software and documentation. Before you install the hardware, install the software on a client Windows PC so that you have access to the product documentation and Release Notes.

### SetNetGo Operating System 4.9.x

SetNetGo runs on each AIV and Enterprise Manager appliance. It is the host operating system (OS) in which fleet AIV software applications (ARAM and ARAMCentral) run.

You can use a Web browser to connect directly to SetNetGo on any AIV or Enterprise Manager 2100. This direct connection enables you to do configuration tasks through SetNetGo without using the MobilePlanner user interface, which requires a license.

You use SetNetGo to configure the Ethernet settings for the platform, upgrading software, and performing systems diagnostics, such as retrieving log files. You can access SetNetGo when connected via the maintenance and management Ethernet ports, or via wireless Ethernet if enabled.

There are several ways to access SetNetGo:

- A direct Ethernet connection (Cat-V cable) between your PC client and the dedicated IP address of the maintenance Ethernet port on the device (Enterprise Manager 2100 or AIV.)
- A Web browser over the network, using the SetNetGo Web user interface. After you configure the network, you access the interface through the assigned IP address of the device on which SetNetGo runs.
- The SetNetGo interface that is integrated into the licensed MobilePlanner software.

### Mobile Robot Software Suite Version 4.9.x

The Mobile Robot Software Suite includes all of the software used for Omron Adept AIV's and the Enterprise Manager appliance, with the exception of the SetNetGo OS, which is supplied as a separate software package.

## MobilePlanner in Fully Licensed Mode

MobilePlanner runs on the Windows client PC. You use its graphical user interface to operate, manage, and monitor your fleet of AIVs. You can also access SetNetGo directly from the MobilePlanner GUI.

For your AIVs to perform autonomous mobile activities, you must make a map of its operating space, and configure its operating parameters. After you generate a map for a workspace where AIVs operate, you can share it between multiple AIVs in one fleet.

Use MobilePlanner to make the map and to perform this configuration. MobilePlanner software requires at least one license for each fleet of AIVs.

## MobilePlanner in Operator Mode

Use MobilePlanner in Operator Mode to monitor one or more AIV's activities and have them perform mobile tasks in the mapped space. When you start MobilePlanner without its license dongle, it defaults to this mode. Refer to the separate *Mobile Robot Software Suite User's Guide* for details.

## ARAM

The Advanced Robotics Automation Management software (ARAM) runs on the AIV. It operates ranging sensors such as the safety scanning laser and sonar, and performs all the high-level, autonomous robotics functions, including obstacle avoidance, path planning, localization and navigation, then sends motion commands to the MARC firmware. ARAM also controls the battery and indicators, and manages digital and analog I/O, which, along with the AIV battery power, provide for integration of application-specific sensors and effectors (user-supplied).

ARAM manages wired and wireless Ethernet communications with offboard software, for external monitoring, development, and systems coordination, including coordination of a fleet of AIVs through the Enterprise Manager 2100 system. It also manages integration with other systems, as well as external monitoring, setup, and control with the MobilePlanner application.

## ARAMCentral

ARAMCentral is the software that manages the AIV fleet and runs on the Enterprise Manager appliance. This software and the appliance combined are referred to as the Enterprise Manager 2100.

The ARAMCentral software distributes and manages the following resources and data for all Fleet AIVs:

- The shared workspace map.
- The shared configuration.
- Traffic control. This includes multi-AIV avoidance, destination, standby, and dock control.
- Queuing of jobs.
- Remote I/O, if you are using it this feature.

### ARCL Protocol

The Advanced Robotics Command Language (ARCL) is a simple, text-based command and response server for integrating an AIV (or fleet of AIVs) with an external automation system. ARCL is similar to a command-line interface (CLI) or a scripting function.

ARCL enables you to operate and monitor the AIV, its accessories, and its payload devices over the network, whether or not you use MobilePlanner.

### Mobile Adept Robot Controller (MARC)

At the lowest level, a microcontroller running MARC firmware handles the details of platform mobility, including maintaining the platform's drive speed and heading, as well as acquiring sensor readings, such as from the encoders and gyroscope, and managing the platform's emergency stop systems, bumper, and joystick. The MARC firmware computes and reports the platform's odometry (X, Y, and heading) and a variety of other low-level operating conditions to ARAM.

### Peripheral Devices

- **Touchscreen Support**—The Mobile Software suite includes support software for the optional AIV touchscreen user interface device.
- **Call/Door Box Support**—Call/Door Boxes are devices that you can use to summon an AIV remotely. These devices contain one software component on the boxes and while the other persists on either the Enterprise Manager 2100 or on single AIV, (when there is no Enterprise Manager 2100).

## 1.6 Supported Enterprise Manager 2100 Deployments

This section provides an overview of potential deployment scenarios so that you can plan your EM2100 deployment. Later sections describe the detailed configuration steps.

The Enterprise Manager 2100 (EM2100) is a replacement upgrade for the Enterprise Manager 1100, (EM1100) which is end-of-life. The EM2100 remains backward compatible with the EM1100 for mixed-model Autosync configurations. However, to support mixed model Autosync, you must:

- Modify the Ethernet cabling.
- Install SetNetGo 4.9.X and Mobile Robot Software Suite 4.x on both the EM1100 Secondary appliance and the EM2100 Primary appliance.
- Always configure the EM1100 as the Secondary appliance. The default (shipped) configuration for an EM2100 is as a Primary appliance.

This release supports the following deployment scenarios:

- **New Standalone EM2100**—Install and configure a new EM2100 standalone appliance.
- **New EM2100 Autosync Pair**—Install and configure two new EM2100 appliances, one as the Primary appliance and the other as the Secondary (back up) appliance.
- **Convert a Standalone EM1100 to Autosync**—Add a new EM2100 as a Primary appliance and convert the existing standalone EM1100 to a Secondary appliance.
- **Replace a Failed Primary Autosync EM1100**—Remove the failed EM1100 Primary

appliance and add a new EM2100 as a Primary appliance.

- **Replace a Failed Secondary Autosync EM1100**—Remove the failed EM1100 Secondary appliance and add a new EM2100 as the Primary appliance. Convert the EM1100 to a Secondary appliance.

## Enterprise Manager 2100 Autosync Failure Scenarios

You can replace a failed EM2100 standalone appliance only with the same model.

If an appliance fails after you configure an EM2100 autosync pair, you replace the failed EM2100 with a new EM2100 as follows:

- **Replace a Failed Primary Autosync EM2100**—Remove the failed EM2100 Primary appliance and add a new EM2100 as a Primary appliance. (The default shipped operating mode). Generate an SSL key to upload to the Secondary.
- **Replace a Failed Secondary Autosync EM2100**—Remove the failed EM1100 Secondary appliance and add a new EM2100 as the Primary. Configure the replacement EM2100 as a Secondary appliance and upload the SSL key from the Primary.

## 1.7 How to Get Help

To obtain support assistance with your software or hardware, see the Omron Adept Technologies, Inc. information on the website at: <http://www.ia.omron.com>.

### Related Manuals

This manual describes the installation and startup of an Enterprise Manager appliance running the Mobile Robot Software Suite. There are additional manuals that describe how to program your fleet, reconfigure installed components, and to add other optional or related components.

The following manuals provide information about safety, related products, advanced configurations and system specifications.

Table 1-2. Related Manuals

| Manual Title  | Description   |
|---|---|
| <i>Mobile Robot LD Safety Guide</i>                       | Describes AIV safety aspects.   |
| <i>Advanced Robotics Command Language Reference Guide</i> | Describes the Advanced Robotics Command Language (ARCL), which is a simple, text-based server from which you can control Omron Adept Technologies, Inc. AIVs. |
| <i>Mobile Robot Software Suite User's Guide</i>           | Describes the software for AIVs and the Enterprise Manager 2100.  |
| <i>LD Platform OEM User's Guide</i>                       | Describes the operation and maintenance of the AIV.   |
| <i>LD Platform Cart Transporter User's Guide</i>          | Describes the operation and maintenance of the Car Transporter AIV.   |
| <i>LD Platform Peripherals Guide</i>                      | Describes various peripherals available for use with AIVs.  |

## **Service and Support**

If, after reading this manual, you are having problems with your Enterprise Manager appliance, contact your local Omron support.



# Chapter 2: Safety

This chapter provides information about product safety. It includes the following topics.

|  |    |
|--|----|
| <a href="#">2.1 Alert Levels</a> .....                                       | 17 |
| <a href="#">2.2 Safety Precautions for the Enterprise Manager 2100</a> ..... | 19 |
| <a href="#">2.3 Disposal</a> .....   | 20 |

## 2.1 Alert Levels

There are three levels of alert notation used in Omron Adept Technologies, Inc. manuals. In descending order of importance, they are:



**DANGER:** Identifies an imminently hazardous situation which, if not avoided, is likely to result in serious injury, and might result in fatality or severe property damage.



**DANGER:** Identifie une situation dangereuse imminente qui, si elle n'est pas évitée, est susceptible d'avoir comme résultat une blessure grave et pourrait provoquer le décès ou des dommages matériels importants.



**WARNING:** Identifies a potentially hazardous situation which, if not avoided, will result in minor or moderate injury, and might result in serious injury, fatality, or significant property damage.



**AVERTISSMANT:** Identifie une situation dangereuse potentielle qui, si elle n'est pas évitée, aura comme résultat une blessure mineure ou modérée et pourrait provoquer une blessure grave, le décès, ou des dommages matériels significatifs.









**CAUTION:** Identifies a potentially hazardous situation which, if not avoided, might result in minor injury, moderate injury, or property damage.



**ATTENTION:** Identifie une situation dangereuse potentielle qui, si elle n'est pas évitée, pourrait avoir comme résultat une blessure mineure ou des dommages matériels.

## Alert Icons

The icon that starts each alert can be used to indicate the type of hazard. These will be used with the appropriate signal word - Danger, Warning, or Caution - to indicate the severity of the hazard. The text following the signal word will specify what the risk is, and how to avoid it.

| Icon  | Meaning  | Icon   | Meaning   |
|---|--|--|---|
|    | This is a generic alert icon. Any specifics on the risk will be in the text following the signal word.<br>Ceci est un symbole générique d'alerte. Toute spécificité concernant le risque sera décrite dans le texte après le mot de signalement. |   | This identifies a hazardous entanglement situation.<br>Ceci identifie une situation dangereuse d'enchevêtrement.  |
|    | This identifies a hazardous electrical situation.<br>Ceci identifie une situation dangereuse électrique.   |   | This identifies a fire risk.<br>Ceci identifie un risque d'incendie.  |
|   | This identifies a hazardous burn-related situation.<br>Ceci identifie une situation dangereuse de brûlure.   |  | This identifies a laser emitter eye damage situation.<br>Ceci identifie une situation dangereuse liée aux lésions oculaires provoquées par un émetteur laser. |
|  | This identifies a hazardous ESD situation.<br>Ceci identifie une situation dangereuse ESD (décharges électrostatiques).  |  |   |

## Special Information

There are several types of notation used to call out special information.

**IMPORTANT:** Information to ensure safe use of the product.

**NOTE:** Information for more effective use of the product.

**Additional Information:** Offers helpful tips, recommendations, and best practices.

**Version Information:** Information on differences in specifications for different versions of hardware or software.

## 2.2 Safety Precautions for the Enterprise Manager 2100

Read the installation and operation instructions before using the appliance.

If you use the supplied rail kit to install the appliance into a 4-post datacenter rack, make sure you read and follow the safety instructions provided with the rack.

### General Hazards



**CAUTION: PERSONAL INJURY RISK.** Do not begin any tasks in this manual that result in activating an AIV (mobile robot) until you have read the important safety information in the Mobile Robot LD Safety Guide and in the AIV's user manuals.



**ATTENTION: RISQUE DE BLESSURES PERSONNELLES.** Ne pas initialiser une tâche dans ce manuel qui ait comme résultat l'activation d'un AIV (robot mobile) avant de lire les renseignements importants de sécurité dans le Guide de Sécurité LD pour Robots Mobiles et dans les manuels d'utilisation AIV.



**CAUTION: PERSONAL INJURY RISK.** Observe all safety precautions when installing the appliance in a computer rack. Two persons might be required to safely lift and install the appliance into a tall rack.



**ATTENTION: RISQUE DE BLESSURES PERSONNELLES.** Respecter toutes les précautions de sécurité lors de l'installation de l'appareil dans un support d'ordinateur. Deux personnes pourraient être nécessaires pour élever et installer l'appareil dans un support haut en toute sécurité.



**WARNING: ELECTROCUTION RISK.** This appliance uses AC power and presents an electrical shock hazard if used improperly. Do not open the enclosure. No user-serviceable parts are included inside.



**AVERTISSMANT: RISQUE D'ÉLECTROCUTION.** Cet appareil utilise du courant CA et présente un risque de choc électrique s'il n'est pas utilisé de manière adéquate. Ne pas ouvrir le boîtier. Aucune pièce interne réparable par l'utilisateur.



**WARNING: ELECTROCUTION RISK.** Failing to properly ground equipment that uses hazardous voltages could lead to injury or death of a person touching the equipment during an electrical fault.



**AVERTISSMANT: RISQUE D'ÉLECTROCUTION.** Ne pas mettre correctement à la terre un équipement utilisant des tensions dangereuses pourrait avoir comme résultat la blessure grave, même le décès d'une personne qui le toucherait pendant une panne électrique.



**WARNING: ELECTROCUTION RISK.** AC power installation must be performed by a skilled and instructed person. Ensure compliance with all local and national safety and electrical codes for the installation and operation of the equipment.



**AVERTISSMANT:** L'installation CA sera effectuée par une personne qualifiée et instruite. Assurer la conformité avec tous les codes de sécurité et électriques locaux et nationaux lors de l'installation et du fonctionnement de l'équipement.

### Additional Safety Information

Contact your local Omron support for other sources of safety information:

## 2.3 Disposal



Dispose of in accordance with applicable regulations.

Customers can contribute to resource conservation and protecting the environment by the proper disposal of WEEE (Waste Electronics and Electrical Equipment). All electrical and electronic products should be disposed of separately from the municipal waste system via designated collection facilities. For information about disposal of your old equipment, contact your local Omron support.

# Chapter 3: Installation

This chapter describes how to physically install the Enterprise Manager appliance hardware. It includes the following topics.

|  |    |
|--|----|
| <a href="#">3.1 Prepare Your Site for the Enterprise Manager 2100</a>    | 21 |
| <a href="#">3.2 Transport and Storage of the Enterprise Manager 2100</a> | 23 |
| <a href="#">3.3 Unpack the Shipment</a>                                  | 24 |
| <a href="#">3.4 Sliding Rail Kit for Rack Mounting</a>                   | 25 |
| <a href="#">3.5 Connect Power to the Enterprise Manager 2100</a>         | 33 |
| <a href="#">3.6 Plan for Disaster Tolerance</a>                          | 34 |
| <a href="#">3.7 Installing a Secondary Appliance</a>                     | 34 |

## 3.1 Prepare Your Site for the Enterprise Manager 2100

Use this information to prepare a site for an Enterprise Manager 2100 installation.



**WARNING: HAZARDOUS ENVIRONMENTS.** Omron Adept Technologies, Inc. does not intend that you use the Enterprise Manager appliance in hazardous environments (explosive gas, water, dust, oil mist). The appliance has an IP rating of IP20 (NEMA Type 1).



**AVERTISSEMENT:** Omron Adept Technologies, Inc. n'a pas conçu l'appareil Enterprise Manager pour être utilisé dans des environnements à risque (gaz explosif, eau, poussière, brouillard huileux). L'appareil a un indice IP20 (NEMA Type 1).

For other technical specifications and requirements, see: Technical Specifications on page 79.

### Site Rack Requirements

Each Enterprise Manager 2100 requires 1U (44.50 mm, 1.75 inches) of space in a standard 19-inch (48.3 cm) 4-post rack datacenter rack, installed as follows:

- The appliance requires a minimum of four support points at the sides, or a rack shelf that provides full support for the chassis enclosure.
- You must secure the appliance to the rack with screws. This prevents anyone from attempting to slide the appliance out of the rack.

**IMPORTANT:** Do not install this appliance in a 2-post rack, or mount it by the chassis bezel brackets (*ears*) alone. If you do not use the supplied rail kit, you use a support shelf or support brackets that takes the full weight of the appliance.

If you use a Secondary appliance, consider installing it in a rack that is remote from the Primary appliance to improve disaster tolerance. See also: Plan for Disaster Tolerance on page 34.



**DANGER: PERSONAL INJURY RISK.** When installing equipment into a rack, read and follow all safety instructions in the rack documentation. Follow the instructions for stabilizing the rack before you begin the installation.



**DANGER: RISQUE DE BLESSURES PERSONNELLES.** Lors de l'installation de l'équipement dans un support, lire et suivre toutes les instructions de sécurité de la documentation du support. Suivre les instructions pour stabiliser le support avant de commencer l'installation.



**WARNING: PERSONAL INJURY RISK.** Installation might require two people to safely lift and install this equipment in a tall rack.



**AVERTISSMANT: RISQUE DE BLESSURES PERSONNELLES.** Deux personnes pourraient être nécessaires pour élever et installer l'appareil dans un support haut en toute sécurité.

## Site Electrical Power Requirements

The appliance requires the power specified in: Power Requirements on page 79. Adhere to the electrical safety information in: Safety on page 17, and make sure that you:

- Ground and bond the rack according to local electrical specifications.
- Complete any necessary electrical work in accordance with local regulations. Electrical installers must be suitably trained and qualified to perform the work.

Omron Adept Technologies, Inc. recommends that you use an uninterruptible power supply (UPS) for the Primary appliance and a separate UPS for an optional Secondary appliance. If you do not use an UPS, and you install two appliances in the same rack, connect each appliance to different power distribution units (PDUs) on separate circuits for power redundancy.

## Electrical Wiring



**DANGER: ELECTROCUTION RISK.** Follow all local safety regulations that determine who can install such equipment, and how to install it. Adhere to all local safety and mechanical regulations governing the installation of rack-mounted computer equipment, including power supply, connectors, grounding and wiring.



**DANGER: RISQUE D'ÉLECTROCUTION.** Respecter toutes les réglementations de sécurité locales qui établissent qui peut installer un tel équipement et la méthode d'installation. Respecter toutes les réglementations locales en matière de sécurité et de mécanique régissant l'installation des équipements informatiques montés sur support, notamment l'alimentation, les connecteurs, la mise à la terre et le câblage.

Your Enterprise Manager 2100 shipment includes approved power cables for several global locales. If it is necessary to manufacture custom power cables to comply with site-specific or equipment-specific wiring, make sure that the cable rating and capacities comply with the specifications in: Power Requirements on page 79.

Chassis grounding occurs at the screws mounting the appliance to the rack through its rail kit. If wired grounding (or bonding) is a requirement for your site, use an appropriate custom cable according to local electrical regulations.

## Site Networking Requirements

### Local Area Network (LAN) Requirements

An Enterprise Manager 2100 running the Mobile Robot Software Suite requires network connections to:

- AIV wireless network
- Operator Terminal(s)
- Factory equipment management systems (WMS or MES)

You require two static IP addresses for the Enterprise Manager appliance and one for each AIV in the fleet. The Management and Fleet networks use these static addresses. Depending on the network infrastructure, you can use a different subnet for each network. This is not an operating requirement, but it will enable you to isolate fleet data traffic from management traffic for enhanced security.

### Wireless Network Requirements.

The Mobile Robot Software Suite User's Guide and the AIV user's guide provides additional information about wireless network requirements and requirements for network access points. Be aware of the specific requirements for wireless network coverage and bandwidth.

Network resource availability can affect Enterprise Manager 2100 performance and the number of AIVs supported. See also: Number of AIVs Supported by an Enterprise Manager 2100 on page 9.

## 3.2 Transport and Storage of the Enterprise Manager 2100

Ship or store the Enterprise Manager 2100 appliance only in its original factory packaging. The packaging prevents damage from typical shipping handling. Protect the package from excessive shock and vibration during shipping or in-house relocation.

For information about the physical characteristics of the appliance, see: Technical Specifications on page 79.

You must ship or store the appliance:

- Within the environmental limits specified in Technical Specifications on page 79 in an area (or vehicle) that is clean, dry, temperature-controlled, with low humidity.
- In accordance with the original package labeling, which describes package orientation and handling requirements.

### 3.3 Unpack the Shipment

Unpack the shipment on a clean, level, electrostatic discharge-safe (ESD-safe) surface that is adjacent to the installation location. Make sure that the workspace is large enough to accommodate both the shipping carton and the unpacked appliance.



**CAUTION: ESD DAMAGE RISK.** Protect the appliance from damage caused by electrostatic discharge (ESD). wear a grounded wrist-strap or shoe strap before you remove the antistatic cover.



**ATTENTION: RISQUE DE DÉCHARGE ÉLECTROSTATIQUE.** Protéger l'appareil contre les dommages provoqués par les décharges électrostatiques (ESD). Portez un bracelet antistatique à la poignée ou à la cheville avant de retirer le couvercle antistatique.

### Before You Unpack the Enterprise Manager 2100

Before you unpack the appliance:

- Orient the carton only as indicated by its labeling (This Way Up).
- Carefully inspect the packaging for evidence of damage during transit. If you find packaging damage, request that the carrier's agent is present when you open the packaging.

As you do the unpacking:

1. Compare the actual items received (not just the packing slip) with your equipment purchase order.
2. Verify that all items are present and that the shipment is correct. Hardware Supplied with the Enterprise Manager 2100 on page 10.
3. Inspect each component for external damage as you unpack it. Contact your local Omron support immediately if you see any damage. See: How to Get Help on page 15.

### Unpack the Enterprise Manager 2100 Shipping Carton

1. Place the shipping carton on a stable, flat surface.
2. Use only a safety box cutter to cut the packing tape. Do not use any other type of knife because you might damage the contents. Open the carton as shown in Figure 3-1.





Figure 3-1. EM2100 Shipping Carton Content

- Verify that the shipping carton contains the items listed in Table 3-1.

Table 3-1. Description of the Shipping Carton Content

| Callout  | Description                        |
|----------|------------------------------------|
| <b>1</b> | Appliance in an anti-static bag.   |
| <b>2</b> | Shock-absorbing corners.           |
| <b>3</b> | Accessories and documentation bag. |
| <b>4</b> | Mounting rail kit.                 |
| N/A      | Power cables (not shown).          |

- Remove the accessories bag [3], the rail kit box [4] and the power cables.
- Carefully lift out the appliance [1] and remove the four shock absorbing [2] corners and then remove the antistatic bag.
- Put the packaging items back in the shipping carton and retain it for future use. Omron Adept recommends that you ship or move the appliance only in its original packaging.

### 3.4 Sliding Rail Kit for Rack Mounting

Your Enterprise Manager 2100 shipment includes a universal sliding rail kit compatible with generic data center 4-post rack systems. You can adapt the rail kit to:

- Both round hole and square hole rack posts. It does not require cage nuts for square holes.
- Several different rack post profiles.

You cannot install the Enterprise Manager 2100 in a 2-post (Telco style) rack. The bezel brackets (*ears*) are not designed to support the chassis weight. However, you might be able to use 2-post racks for your appliance:

- In a non-sliding configuration that supports the chassis sides with fasteners at least 4 points.
- On a rack shelf that fully supports the appliance.

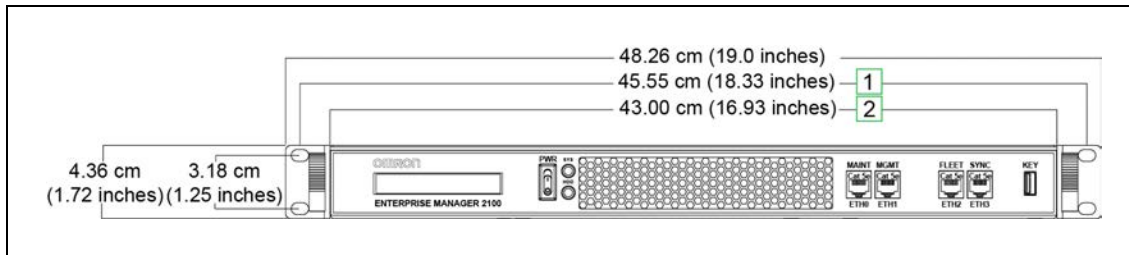

Figure 3-2. Enterprise Manager 2100 Appliance Dimensions

Table 3-2. Callouts in Figure 1-2

| Callout | Description                              |
|---------|--|
| 1       | Chassis enclosure width.                 |
| 2       | Distance between front lock-screw holes. |



**WARNING: PERSONAL INJURY RISK.** When operating the telescoping rail during assembly or normal use, take care that you do not insert your fingers between moving parts.



**AVERTISSMANT: RISQUE DE BLESSURES PERSONNELLE.** Lors de l'utilisation du rail télescopique pendant le montage ou l'utilisation normale, veiller à ne pas insérer les doigts entre les pièces mobiles.



**WARNING: HEAVY COMPONENT.** Although one person can lift the appliance, you might require a minimum two person lift if you install the appliance into the upper locations of a tall (183 cm, 72 inch) rack. Take particular care if you use step ladders or step stools.



**AVERTISSMANT: COMPOSANT LOURD.** Bien qu'une seule personne puisse soulever l'appareil, un nombre minimum de deux personnes pourrait être nécessaire pour installer l'appareil dans un support haut (183 cm, 72 pouces). Prendre un soin particulier lors de l'utilisation d'une échelle ou d'un tabouret-escabeau.



**DANGER: TIPPING RISK.** If a computer equipment rack is not ganged to other racks, bolted to the floor, or fitted with an extending stabilizer foot, it might tip when equipment is fully extended from the rack. Do not install equipment in a rack unless you are sure that it is stable and safe.



**DANGER: RISQUE D'INSTABILITÉ.** Si un support d'équipement informatique n'est pas connecté à d'autres supports, boulonné au sol ou équipé d'un pied stabilisateur extensible, il risque de basculer lorsque l'équipement est complètement sorti du support. Ne pas installer d'équipement dans un support à moins d'être certain qu'il est stable et sûr.

## Components in the Sliding Rail Kit

The sliding rail kit provided with your Enterprise Manager 2100 appliance includes:

- Inner sliding rail - Attach the rail to the appliance chassis.
- Adjustable telescoping track - Use adjustable brackets to attach the track to the rack posts.
- Four fixed L-clamps.
- Four adjustable L-brackets.
- The fasteners described in Table 3-3.

Table 3-3. Rail Kit Fasteners

| Type and Quantity | Threaded Length     | Recommended Torque |
|-------------------|---------------------|--------------------|
| M5 (4)            | 15 mm (0.59 inches) | 4.5 ft-lb (6 N·m)  |
| M5 (8)            | 8 mm (0.314 inches) | 4.5 ft-lb (6 N·m)  |
| M4 (8)            | 6 mm (0.236 inches) | 2 ft-lb (3 N·m)    |
| M4, Black (8)     | 4 mm (0.157 inches) | 2 ft-lb (3 N·m)    |
| Washer (8)        | N/A                 | N/A                |

**NOTE:** To prevent fasteners from loosening because of vibration, use Loctite Blue 242 Adhesive, except where electrical grounding is a requirement.

## Tools Required to Install the Sliding Rail Kit

You require the following tools to install the Sliding Rail Kit:

- Phillips torque screwdriver with #2 bit.
- Masking tape and pen to mark the rack post positions.
- Spring or screw clamp to temporarily hold the rail in position while fastening.
- Thread locking liquid.

In addition, if you do not have the help of another person when mounting the track to the rack posts, a small spring clamp is useful to hold one end of the track in position as you work on the other end.

## Determine the Sliding Rail Kit Installation Location and Method

Determine the installation location as follows:

1. Decide the height position (U location) where you want to install the appliance.
2. Use masking tape (or similar) to mark the installation location on all four rack posts.

## Remove the Sliding Rail from the Track

Remove the sliding rail from the telescoping track as follows:

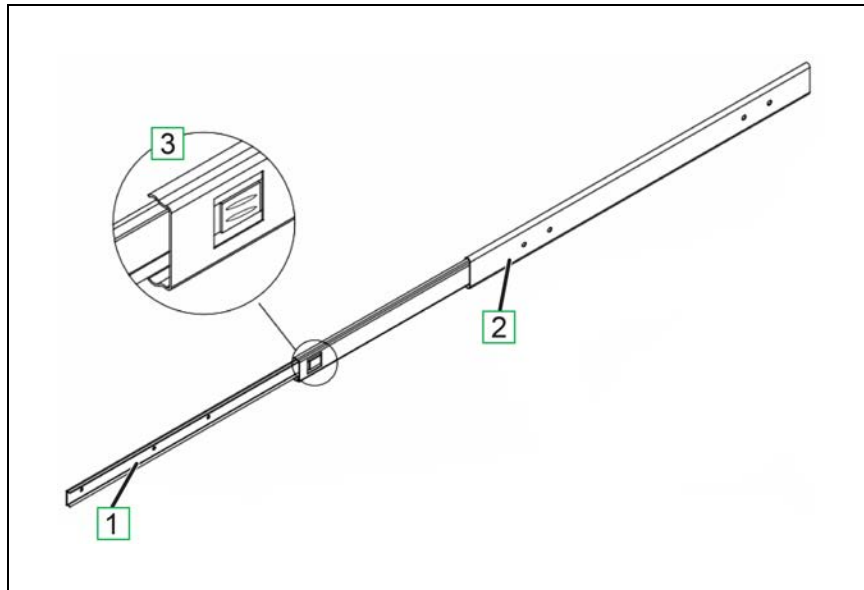

Figure 3-3. Remove the Rail From the Track (Right Assembly Shown).

1. Pull the end of the sliding rail [1] until it is fully extended from the track [2] engaging the locking button [3].
2. Press the locking button [3] and continue to pull the sliding rail [1] removing it completely from the track.
3. Repeat Step 1 and Step 2 for the second rail assembly.

## Attach the Sliding Rail to the Chassis

Attach the sliding rail to the appliance chassis as follows:

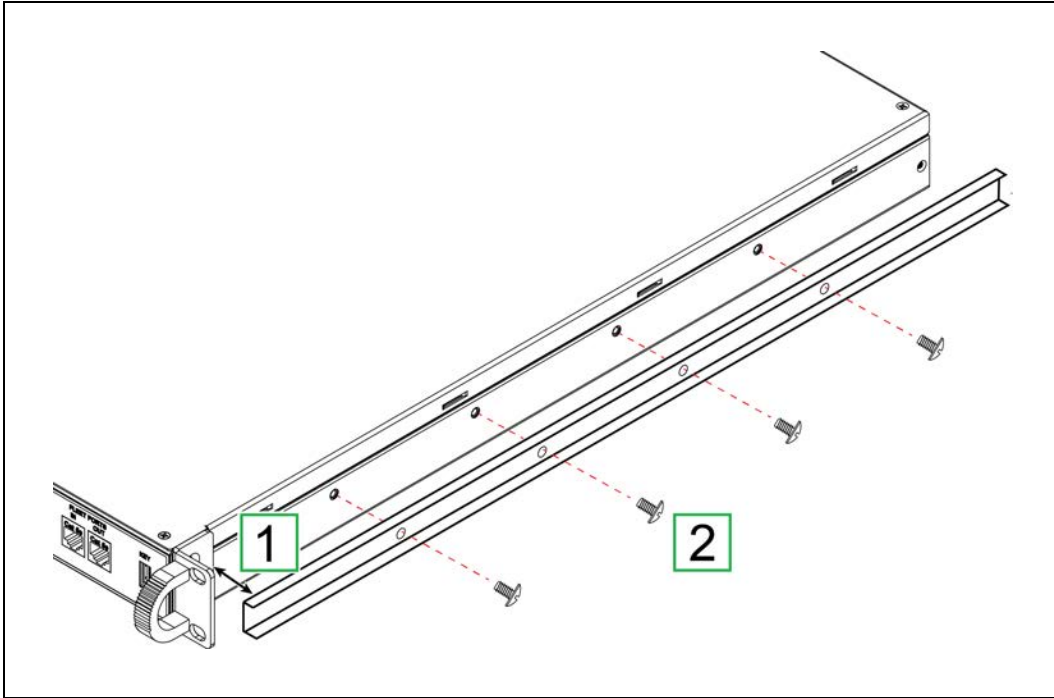

Figure 3-4. Attach the Rail to the Appliance Chassis (Right Assembly Shown).

1. Align the end of the sliding rail with the notch in the chassis pull brackets [1].
2. Attach the rail with four 6 mm M4 screws [2]. Torque each screw to 2 ft-lb (3 N·m).
3. Repeat Step 1 and Step 2 for the second sliding rail.

### Attach the Adjustable Brackets to the Track

Attach the larger, adjustable L-shaped brackets to the telescoping track as follows:

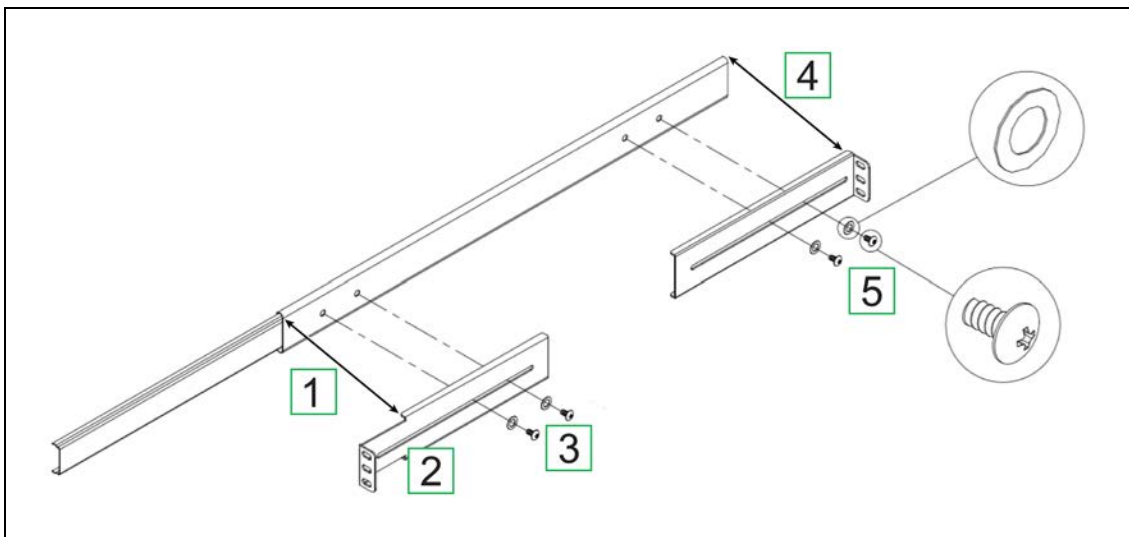

Figure 3-5. Attach the Large L-Brackets to the Track (Right Assembly Shown).

1. Identify the brackets by a letter stamped into the metal: F—Front and R—Rear.
2. Align the front bracket [2] with the front end of the outer track [1].
3. Attach the front L-bracket with two 4 mm M4 black screws and washers [3]. Torque each screw to 2 ft-lb (3 N·m).
4. Align the rear bracket with the rear end of the outer track [4].
5. Attach the rear L-bracket with two 4 mm M4 black screws and washers [5]. Tighten each screw loosely, enabling the bracket to slide.
6. Repeat Step 1 through Step 5 for the second track.

### Determine the Mounting Method for the Sliding Rail Kit

Determine which fastener holes you will use to attach the sliding rail kit to the rack posts. The sliding rail kit adapts to different rack post profiles in several ways:

- Adjust the position of the L-bracket to contact the inner or outer surfaces of the rack post.
- Rotate the L-clamp as necessary to clamp and fasten the L-bracket to the rack posts.
- For some rack post profiles, you might be able to attach the L-bracket directly to the post without requiring the L-clamp.

### Attach the Track to the Rack Posts

The following procedure is typical of most rack post profiles.

### Adjust the Track to Span the Rack Posts

Move the rear L-bracket so that both L-brackets span the outer faces of the front and rear rack posts as follows:

1. Use masking tape to mark all four U-locations on the rack posts.
2. Position the track so that the front L-bracket is on the outer face of the front rack post.
3. Slide the loose rear L-bracket [1] until it aligns tightly with the outer face of the rear rack post. Temporarily tape the rear L-bracket to the track to prevent it from moving.
4. Tighten the two 4mm M4 black screws and washers to secure the L-bracket to the track. Torque each screw to 2 ft-lb (3 N·m).

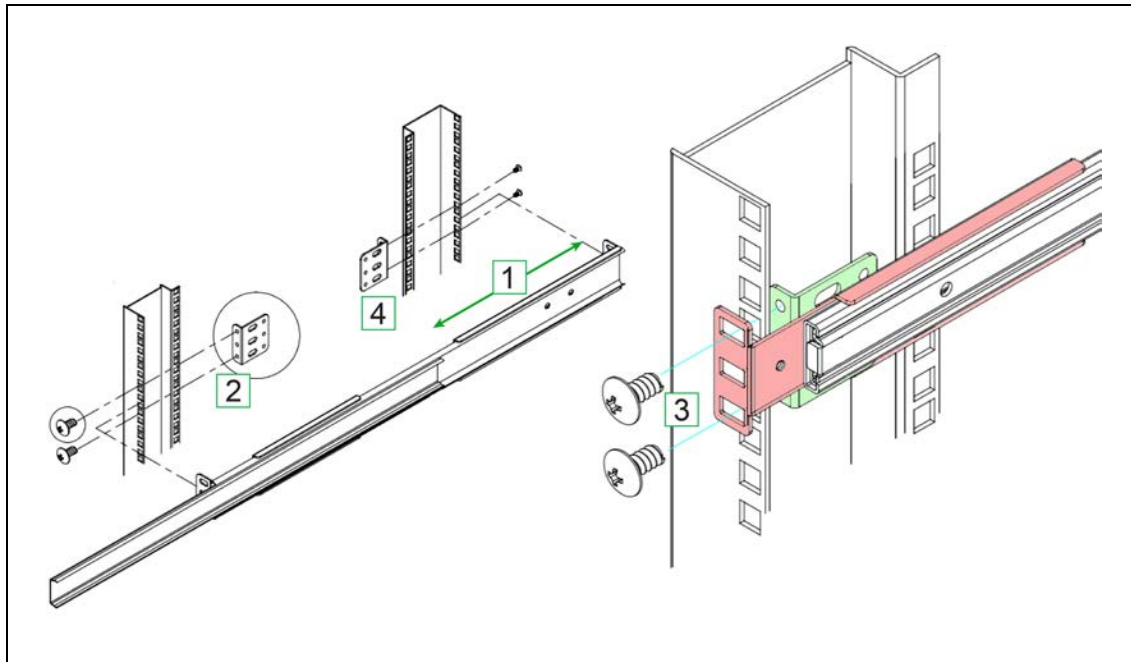

Figure 3-6. Adjusting and Attaching the Track to the Rack Posts

#### Attach the Track to the Rack Posts

Attach the track to the rack post as follows:

1. Position the track so that the L-clamps are on the outer faces of the front and rear rack posts. Temporarily tape (or have someone hold) the track in position.
2. Place an L-clamp [2] on the **inner** face of the front rack post.
3. Secure the front L-bracket to the L-clamp with two 8mm M5 screws [3], using only the top and bottom holes at the U-location. Torque each screw to 4.5 ft-lb (6 N·m).
4. Repeat Step 2 for the L-clamp at the rear rack post [3].
5. Repeat Step 1 through Step 4 for the remaining track.
6. Check that both slides operate smoothly and do not bind and that the tracks are level and straight.



## Insert the Appliance Into the Track

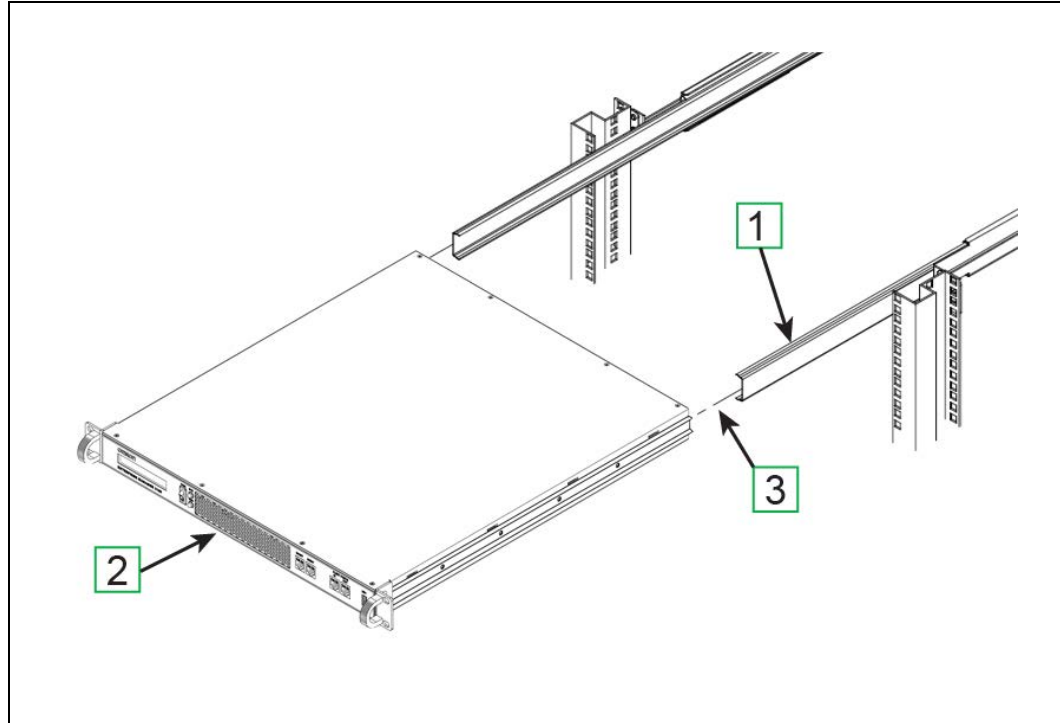

Figure 3-7. Inserting the Chassis Into the Track

1. Slide the telescoping track out a few inches on each side [1].
2. Hold the chassis level and square with the rack [2].
3. Insert the rails into the tracks and push the chassis all the way in until you hear the rails click and lock.
4. Carefully and slowly pull the chassis out again to full extension, making sure that the rail stops at the lock (See [3] in Figure 3-3).
5. Lock in place with an M5 screw.

### 3.5 Connect Power to the Enterprise Manager 2100

The appliance requires a 100 – 240 VAC, 50/60 Hz power supply. Omron Adept Technologies, Inc. recommends that you use a separate uninterruptable power supply (UPS) circuit for each appliance.



**WARNING: ELECTROCUTION RISK.** Make sure that all connections and supply equipment is operationally safe and follow all local regulations concerning the electrical installation of computer devices.



**AVERTISSMANT: RISQUE D'ÉLECTROCUTION.** S'assurer que toutes les connexions et les équipements d'alimentation sont sûrs du point de vue opérationnel et respecter toutes les réglementations locales concernant l'installation électrique des dispositifs informatiques.

1. Connect the AC plug on the rear of the appliance to AC power.
2. Set the rear power switch to ON (I).
3. Use only the front momentary power switch to control AC power during normal operation.

## 3.6 Plan for Disaster Tolerance

Installing a Secondary appliance in a remote location (you must meet all networking requirements) might enable your fleet to tolerate some potential disaster events. A catastrophic local event that affects the Primary Appliance might not affect the Secondary. When a Secondary appliance is available and running, you can quickly recover your AIV fleet operations.

A Secondary appliance is one that is ready to take over operation if the Primary appliance fails. You can install a Secondary appliance as a standby for the Primary. Consider additional planning for disaster tolerance by including UPS, redundant power, and redundant network switching. Such device and power redundancy will help you to recover more quickly with little or no data loss.

**IMPORTANT:** If you have an EM2100 and an EM1100, you must always use the EM1100 as a Secondary appliance. See Supported Enterprise Manager 2100 Deployments on page 14.

If you install a Secondary appliance, follow the hardware procedure described for the Primary appliance. While you can choose to install a Secondary appliance in the same rack as the Primary appliance, connect it to a different UPS and also to a different network switch.

Connect a Secondary appliance to the same network subnet as the primary and consider the following options for a reliable and trouble-free operation:

- Install the Secondary appliance in a different (remote) location in the building.
- Connect each appliance to a separate power circuits and UPS.
- Connect each appliance to separate, interconnected Ethernet switches.
- Connect each Ethernet switch to separate power circuits and UPS.

## 3.7 Installing a Secondary Appliance

If you are installing a Secondary appliance to create an Autosync pair, follow the procedure described for the Primary appliance. While you can install a Secondary appliance in the same rack as the Primary appliance, you should always connect it to a different UPS and also to a different network switch.

Installing the Secondary appliance in a remote location (providing you meet all networking requirements) is a better solution for redundancy. A catastrophic local event that affects the Primary appliance will not affect the Secondary. If the Secondary appliance is available and

running you can quickly recover fleet operations. See [Installing a Secondary Appliance](#) on page 34.



# Chapter 4: Connectors and Indicators

This section describes the available appliance connections, controls and indicators. It includes the following topics.

- [4.1 Overview of the Enterprise Manager 2100](#) ..... 37
- [4.2 Rear Panel Connectors and Features](#) ..... 38
- [4.3 Enterprise Manager 2100 Status Display Panel](#) ..... 39
- [4.4 Connect the Enterprise Manager 2100 to a Network](#) ..... 40

## 4.1 Overview of the Enterprise Manager 2100

This section describes the connectors, indicators, and physical characteristics of the Enterprise Manager appliance, shown in Figure 4-1.

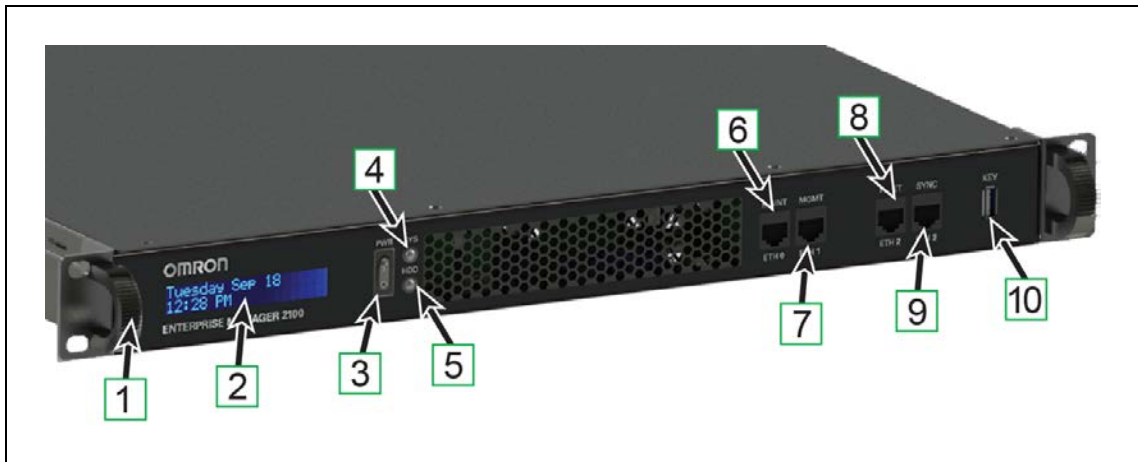

Figure 4-1. Enterprise Manager 2100 Appliance Front Panel Features and Connectors

The front panel features are described in Table 4-1.

Table 4-1. EM2100 Front Panel features

| Callout | Label | Port | Description  |
|---------|-------|------|--|
| 1       | n/a   | n/a  | Pull handle for removing the appliance from the rack (when mounted in a sliding rail kit only).  |
| 2       | n/a   | n/a  | Display panel. This 40-Char (2x20) LCD display provides status, warning, and error information. For details, see: Enterprise Manager 2100 Status Display Panel.      |
| 3       | PWR   | n/a  | Momentary power switch. Press and release immediately to switch power on or off, such as when you intend to restart the appliance manually (a <i>soft restart</i> ). |

| Callout | Label | Port | Description  |
|---------|-------|------|--|
|         |       |      | If you press and hold the power switch for longer than 4 seconds it causes an immediate software halt (a <i>hard stop</i> ).   |
| 4       | SYS   | n/a  | System indicator LED. Illuminated green during normal operation.   |
| 5       | HDD   | n/a  | Storage activity indicator LED. Illuminated red during hared drive access (data reads and writes).   |
| 6       | MAINT | ETH0 | Maintenance Ethernet network port. Use the Maintenance port for initial setup, troubleshooting, and as an alternate method of access. Its IP address is fixed at 1.2.3.4, and it requires no password. |
| 7       | MGMT  | ETH1 | Management Ethernet network port.  |
| 8       | FLEET | ETH2 | Fleet Ethernet network port. This is a general-purpose LAN connection, used by both AIVs and MobilePlanner for appliance connections.  |
| 9       | SYNC  | ETH3 | Synchronize Ethernet network port. Not used in this release.   |
| 10      | KEY   | n/a  | Front USB port (Service use only).   |

**NOTE:** When operating in standalone configuration, the appliance uses only the AC power, the Management Ethernet connector, and the Fleet Ethernet connector.

## 4.2 Rear Panel Connectors and Features

The EM2100 provides the rear panel connectors and features shown in Figure 4-2.

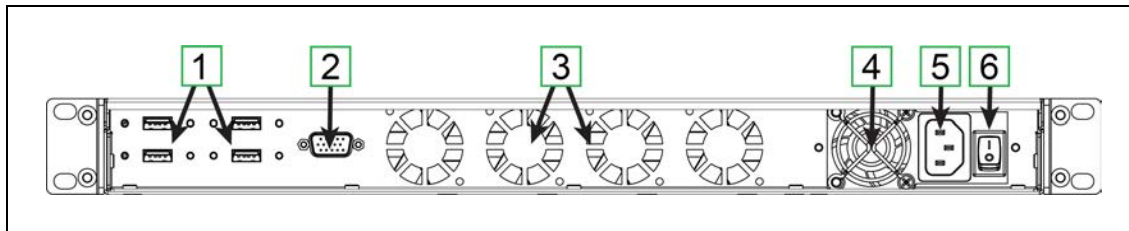

Figure 4-2. EM2100 Rear Panel Connectors and Features

The EM2100 rear panel connectors and features are described in Table 4-2.

Table 4-2. Description of EM2100 Rear Panel Connectors and Features

| Callout | Description  |
|---------|--|
| 1       | Four USB Ports, for service use only.  |
| 2       | SVGA Video DB9 port, for service use only.   |
| 3       | Four auto-speed motherboard cooling fans. Fan speed (and noise volume) varies depending on the CPU load and the ambient temperature. |
| 4       | Power supply cooling fan.  |

| Callout | Description  |
|---------|--|
| 5       | IEC 60320 C14 Power Input connector  |
| 6       | Mains power switch. Keep this set to on (I) and use the front power switch to control power. |

### 4.3 Enterprise Manager 2100 Status Display Panel

The Enterprise Manager 2100 includes an LCD status display panel that provides the information shown in Table 4-3.

Table 4-3. Enterprise Manager 2100 Status Display Messages

| Message  | Description   |
|--|---|
| OMRON ADEPT<br>TECHNOLOGIES                        | Standard splash message during power on.  |
| EM2100 STARTING                                    | Boot message after power on.  |
| MODE: Fleet Manager<br>LINK: ↑↓ ↓↑                 | The operating mode of this appliance.<br>Indicates which Ethernet ports are in use (connected and active). An up arrow ( ↑ ) indicates that the port is in use, a down arrow ( ↓ ) indicates that the port is not in use. |
| ETH2: <###.###.###.###><br>ETH1: <###.###.###.###> | IPv4 address for the Fleet Ethernet port.<br>IPv4 address for the Management Ethernet port.   |
| ASYNC: <mode><br>STATUS: <status>                  | Whether the EM2100 is a Primary or Secondary appliance in an Autosync pair.<br>The status of an Autosync pair: <i>Disabled</i> , <i>Startup</i> , <i>Active</i> , or <i>Failed</i> . See the description below,           |
| UP: <time>   | Time elapsed since the last reboot.   |

#### Autosync Status

The status of an Autosync pair, which can be:

- **Disabled**—The current appliance is Primary, but the Secondary IP Address is 0.0.0.0. Autosync is disabled without a valid Secondary appliance IP Address.
- **Startup**—Autosync is configured, but the two appliances have not yet communicated successfully.
- **Active**—Primary and Secondary appliances are communicating.
- **Failed**—Primary and Secondary appliances are communicating, but the connection is lost. The Primary appliance automatically attempts to re-establish communication with the Secondary appliance.

## 4.4 Connect the Enterprise Manager 2100 to a Network

To use a single Enterprise Manager 2100 as a standalone appliance, connect the Ethernet ports as shown in Figure 4-3.

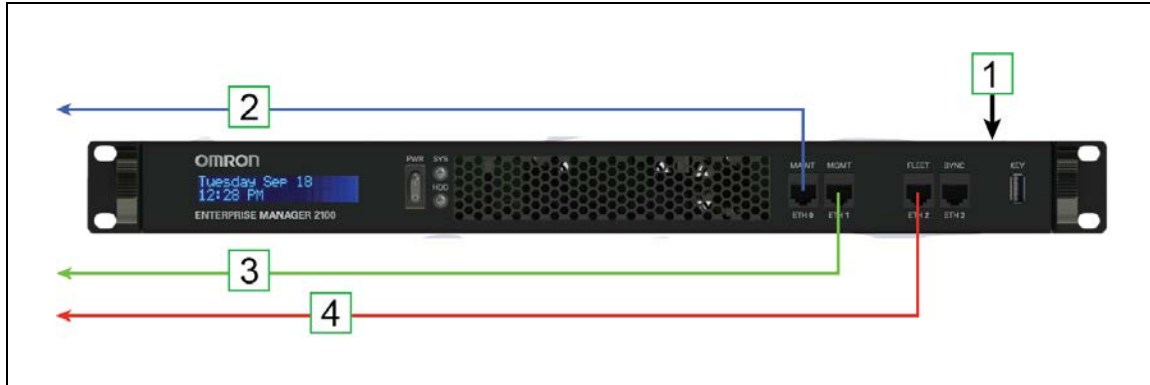

Figure 4-3. Single Enterprise Manager 2100 as a Standalone Fleet Management Appliance

Omron Adept Technologies, Inc. recommends that you use cables that meet a minimum requirement of Category 5e. The connections are described in Table 4-4.

Table 4-4. Cabling a Single Enterprise Manager 2100

| Callout | Label | Port | Description  | Cable To          |
|---------|-------|------|--|-------------------|
| 1       | n/a   | n/a  | Enterprise Manager 2100 configured in standalone mode.   | n/a               |
| 2       | MAINT | ETH0 | The Maintenance port that you use for initial configuration and for emergency access in future. This port has a fixed IP address of 1.2.3.4. | Client Windows PC |
| 3       | MGMT  | ETH1 | The Enterprise Manager 2100 Management port.   | LAN Switch        |
| 4       | FLEET | ETH2 | The Fleet administrative port.   | LAN Switch        |



**CAUTION: NETWORK SECURITY.** Do not connect the Enterprise Manager appliance directly to the Internet. If the Enterprise Manager appliance is on a LAN that has Internet access, make sure there is a firewall between the LAN and the Internet in order to prevent unwanted and unauthorized network traffic from reaching the Enterprise Manager appliance.





**ATTENTION: SÉCURITÉ DU RÉSEAU.** Ne pas connecter l'appareil Enterprise Manager directement à Internet. Si l'appareil Enterprise Manager est connecté à un réseau LAN avec accès à Internet, assurer la présence d'un pare-feu entre le réseau LAN et Internet afin de prévenir le trafic réseau non désiré et non autorisé d'atteindre l'appareil Enterprise Manager..

## Logical Ports and Protocols Used by the Enterprise Manager 2100

An Enterprise Manager 2100 requires the logical ports and protocols described in Table 4-5.

Table 4-5. Logical Ports and Protocols

| Protocol  | Port(s)            | Initiator to Recipient   |
|---|--------------------|--|
| <b>Intra-fleet Communications</b>   |                    |  |
| Used to broadcast configuration updates to AIVs, to dispatch job commands, and to share position and trajectory updates throughout the fleet.                               |                    |  |
| TCP   | 37                 | AIV to Enterprise Manager appliance Maintenance, Management and Fleet ports use this.  |
| TCP/UDP   | 5000               | AIV Enterprise Manager. Fleet port uses this.  |
| UDP   | Range 10000 and up | AIV to Enterprise Manager appliance<br>This protocol uses as many ports as there are AIVs in a fleet. Each connecting AIV uses the next available port $\geq 10000$ . For best results, allow a large number of ports such as 10000-10999. |
| TCP/UDP   | 7272               | AIV to Enterprise Manager appliance  |
| <b>Configuration and Monitoring of Fleet</b>  |                    |  |
| Used for MobilePlanner connections to the Enterprise Manager appliance and AIVs for monitoring and configuration.   |                    |  |
| TCP   | 443                | Client PC to Enterprise Manager appliance<br>Maintenance and Management ports use this.  |
| TCP/UDP   | Range 7272 and up  | Client PC to Enterprise Manager appliance<br>This protocol uses as many ports as there are AIVs. Each AIV that connects uses the next available port $\geq 7272$ . For best results, allow a large number of ports, such as 7272-7999.     |
| TCP/UDP   | 7272               | Client PC to AIV   |
| UDP   | Range 10000 and up | Enterprise Manager appliance to Client PC<br>This protocol uses as many ports as there are AIVs. Each AIV that connects uses the next available port $\geq 10000$ . For best results, allow a large number of ports such as 10000-10999.   |
| UDP   | 10000              | AIV to Client PC.  |
| <b>Job Monitoring and Submission (ARCL Interface)</b>   |                    |  |
| Used for managing jobs on the Enterprise Manager appliance. These are typically submitted from a Warehouse Management System (WMS) or Manufacturing Execution System (MES). |                    |  |
| TCP   | 7171               | WMS/MES to Enterprise Manager appliance<br>ARCL Server: if enabled in the configuration ( <i>Robot Interface</i> and then <i>ARCL Server Setup</i> ), this port is open on the Enter-  |

| Protocol        | Port(s)             | Initiator to Recipient   |
|-----------------|---------------------|--|
|                 |                     | prise Manager and accepts unlimited incoming connections. The port number is configurable.<br>(This port might be available on the AIV, depending on the application.)   |
| TCP             | Configurable port # | Enterprise Manager appliance to WMS/MES<br>Outgoing ARCL Connection: if enabled in the configuration (Robot Interface then Outgoing ARCL connection setup), then the Enterprise Manager initiates an outgoing connection to the specified hostname and TCP port number.  |
| <b>Optional</b> |                     |  |
| TCP             | 123                 | Enterprise Manager appliance to NTP server<br>If you enable a Network Time Protocol (NTP) client Enterprise Manager appliance ( <i>SetNetGo</i> then <i>System</i> and then <i>Date/Time</i> ), the Enterprise Manager appliance attempts to set its clock from the network time server at the specified IP address. (This function is available on the AIV, if you do not use a client Enterprise Manager appliance.) |
| UDP/TCP         | Range 1000-65535    | Offboard devices to AIV<br>If RS232 or Ethernet Port Forwarding is enabled on the AIV ( <i>SetNetGo</i> then <i>Network</i> ) then the configured TCP ports are open on the AIV for incoming connections.  |

## Logical Ports and Protocols Used by a Single AIV

An individual AIV in a Fleet requires the following logical ports and protocols.

| Protocol   | Port(s)             | Initiator ⇄ Recipient   |
|--|---------------------|---|
| <b>Configuration and Monitoring of AIV</b><br>Used for MobilePlanner connections to the AIV for purposes of monitoring and configuration.  |                     |   |
| TCP  | 443                 | Client PC to AIV  |
| TCP/UDP  | 7272                | Client PC to AIV  |
| UDP  | 10000               | AIV to Client PC  |
| <b>Job Monitoring and Submission (ARCL Interface)</b><br>Used for managing jobs on the Enterprise Manager. These are typically submitted from call buttons or other automation equipment |                     |   |
| TCP  | 7171                | Offboard devices to AIV<br>ARCL Server: if enabled in the configuration (Robot Interface and then ARCL Server Setup), then this port is open on the AIV and accepts unlimited incoming connections. The port number is configurable.          |
| TCP  | Configurable port # | Off-board Devices to AIV<br>Outgoing ARCL connection: If enabled in the configuration (Robot Interface and then Outgoing ARCL connection setup), then the AIV initiates an outgoing connection to the specified hostname and TCP port number. |

| Protocol        | Port(s)                 | Initiator ⇄ Recipient  |
|-----------------|-------------------------|--|
| <b>Optional</b> |                         |  |
| TCP             | 123                     | AIV to NTP server<br>If the Network Time Protocol (NTP) client is enabled on the AIV (SetNetGo then System and then Date/Time), the AIV attempts to connect to the configured IP address to synchronize its clock. |
| UDP/TCP         | Range<br>1000-<br>65535 | Off-board Devices to AIV<br>If RS232 or Ethernet Port Forwarding is enabled on the AIV (SetNetGo then Network), the configured TCP ports are open on the AIV for incoming connections.                             |

# Chapter 5: Configuration

This chapter describes the data connections and configuration of the Enterprise Manager appliance. It includes the following topics.

|  |    |
|--|----|
| <a href="#">5.1 Enterprise Manager 2100 Configuration Overview</a>             | 45 |
| <a href="#">5.2 Set the IP Address on a Client PC's Network Adapter</a>        | 47 |
| <a href="#">5.3 Connect Your PC to SetNetGo on the Enterprise Manager 2100</a> | 47 |
| <a href="#">5.4 Configure Management Interface Network Settings</a>            | 49 |
| <a href="#">5.5 Configure the Fleet Interface Network Settings</a>             | 50 |
| <a href="#">5.6 Use NTP to Synchronize Enterprise Manager 2100 Time</a>        | 51 |
| <a href="#">5.7 Enabling the ARCL Server</a>                                   | 52 |
| <a href="#">5.8 Configure Each AIV to Connect to the Enterprise Manager</a>    | 52 |
| <a href="#">5.9 Add a Secondary Appliance for AutoSync</a>                     | 54 |
| <a href="#">5.10 Configure a Secondary Appliance and Autosync</a>              | 54 |
| <a href="#">5.11 Customize Each Fleet AIV</a>                                  | 57 |
| <a href="#">5.12 Call Buttons</a>  | 59 |

## 5.1 Enterprise Manager 2100 Configuration Overview

Enterprise Manager 2100 Configuration varies depending on how you deploy the appliance. See Supported Enterprise Manager 2100 Deployments on page 14.

### Ethernet Connections

The Enterprise Manager appliance provides four built-in Ethernet ports described in: Connect the Enterprise Manager 2100 to a Network on page 40.

Table 5-1. EM2100 Ethernet Ports

| Port                                  | Description and Use  | IP Address     |
|---------------------------------------|--|----------------|
| MAINT ETH0<br>(Maintenance Port)      | The Maintenance port is always enabled and is not password protected. Use this port only configure the appliance or for administrative access.                                 | Fixed: 1.2.3.4 |
| MGMT ETH1<br>(Management Port)        | The SetNetGo access Ethernet port. You can define the IP address.<br>AIVs cannot access this Ethernet port.  | User defined   |
| FLEET ETH2<br>(Fleet Management Port) | The port for AIV and MobilePlanner operational connections.<br>You can define the IP address. This is the connection port for all AIVs, and also for the MobilePlanner client. | User defined   |

| Port                         | Description and Use       | IP Address |
|------------------------------|---------------------------|------------|
| SYNC ETH3<br>(Autosync Port) | Not used in this release. | None       |

Contact your System Administrator for assistance configuring the Enterprise Manager appliance for your network. See also: Site Networking Requirements on page 23.

## Configuration Tasks Overview

To connect to and configure the Enterprise Manager appliance, you must do the following tasks, which are described in detail later in this guide:

- Set an IP address on your PC's Ethernet adapter.
- Connect your PC to the Enterprise Manager appliance.
- Use a browser to access the SetNetGo interface.
- Configure the network settings for the appliance Management Ethernet port.
- Configure the network settings for the FLEET ETH2 Ethernet port.
- Define the login information.
- Configure each AIV to connect to the Enterprise Manager 2100.
- Customize each AIV, if desired.

If you also install a Secondary appliance and configure Autosync, you must also:

- Install the same SetNetGo and ARAMCentral software version on the Secondary as is on the Primary appliance.
- Configure a unique IP address for the Management port.
- Connect the Management port to the LAN.
- Connect the FLEET ETH2 port to the LAN.
- Enter the Secondary Management IP address on the Primary appliance.
- Generate and download a key from the Primary appliance.
- Set the Secondary appliance Autosync role to Secondary.
- Upload the key to the Secondary appliance.
- Verify that the status of both appliances is active.
- Create a direct network connection between the Primary and Secondary appliances.

## 5.2 Set the IP Address on a Client PC's Network Adapter

Use the Maintenance Ethernet port to connect a client PC to the SetNetGo operating system.

**IMPORTANT:** You must assign a static (fixed) IP address. Do not use a DHCP server.

Configure the network adapter IPv4 address on the Client PC as follows:

1. Connect a CAT 5 Ethernet cable from the client PC's Ethernet port to the Maintenance Ethernet port on the EM 2100 appliance.
2. In the command field on the Windows taskbar, enter the following command to open the Network Connections dialog: **ncpa.cpl**
3. Double-click the Ethernet icon to open its Properties dialog, and then click Properties
4. Double-click TCP/IPv4 to open the Internet Protocol properties dialog.
5. Enter as the IP address: 1. 2. 3. 5, or any IP address in the range 1. 2. 3. 0 to 1. 2. 3. 255, excluding 1. 2. 3. 4. (this is reserved for the Maintenance port).
6. Enter as the subnet mask: 255. 255. 255. 0.
7. Press **OK** to close the Internet Protocol dialog, and then press **OK** to close the Ethernet Adapter dialog.

In future, you can use the Maintenance Ethernet port for emergency access to the Appliance at IP address 1.2.3.4. (For example, if you lose the password or if there is a network IP address conflict.)

## 5.3 Connect Your PC to SetNetGo on the Enterprise Manager 2100

SetNetGo enables you to configure and manage Enterprise Manager 2100 and AIV settings. This section describes how to access SetNetGo through the Maintenance port to perform initial configuration.

The user interface for SetNetGo on an Enterprise Manager appliance provides a different set of parameters and options compared to SetNetGo on an AIV. The upper left of the screen shows SetNetGo - ENTERPRISE MANAGER 2100 or SETNETGO - LD, depending on your SetNetGo context (the device on which it runs, such as the Omron Adept Technologies, Inc. LD Platform).

### Connect to SetNetGo and Configure Access and Security

After you connect to the Maintenance Port as described in: Set the IP Address on a Client PC's Network Adapter on page 47 you can open the SetNetGo Web interface.

**NOTE:** Passwords are limited to a maximum of 20 alphanumeric characters. For increased security, specify a long (10+ characters) password string with both uppercase and lowercase letters. Include several integers.

Connect your browser to SetNetGo and configure SetNetGo access as follows:

1. Open a browser and type: HTTP://1. 2. 3. 4 and then press enter.
2. If a certificate warning dialog opens, ignore it and close the dialog.
3. In the SetNetGo web interface, click the Security Tab and then click SetNetGo Access and check **Enabled** next to the following:
  - Management and Fleet Interface.
  - (Optional) Remote reboot.
4. Change the account password (default is no password) as required and click **Apply**.

### Enable Fleet Account Access

If you want to strictly control access to the Fleet through MobilePlanner you can enable *account access* and create authorized user accounts with passwords.

If you enable access control, you must also enable at least the Admin account. You can also:

- Enable default Operator and Viewer accounts.
- Create additional user accounts.
- Modify account *permissions* to control access privileges.

To enable fleet account access

1. In the SetNetGo web interface, click the Security Tab and then click Fleet Accounts and
2. Check **Enabled** next to Access Control and press **Apply**.
3. Wait for the change to take effect and refresh your browser if necessary. (You might see a warning that you enabled access control without creating accounts.)
4. Check **Enabled** next to the admin *Username*.
5. Enter and confirm a new password, and then click **Apply**.
6. Optionally, repeat Step 4 and Step 5 for the default operator and viewer accounts, which have different access privileges compared to the admin account.
7. Optionally add a new named user account and repeat Step 4 and Step 5. If you create a new user account you might also want to click the **Modify Permissions** link to further control user access.

### Access SetNetGo from Mobile Planner

During normal operation, you access SetNetGo through the MobilePlanner software as follows:

1. Start the MobilePlanner software on your PC.
2. Click anywhere in the SetNetGo selection box, to access the SetNetGo interface.



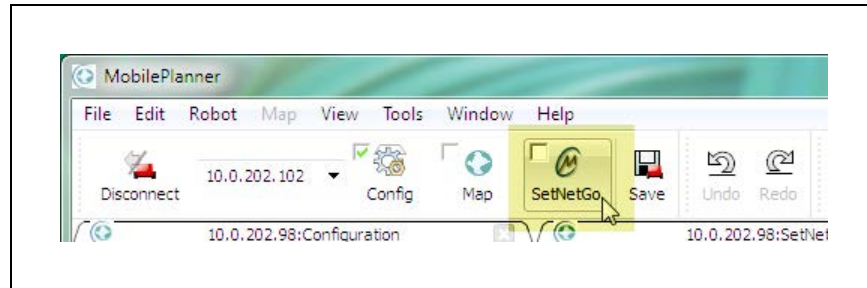

Figure 5-1. Hover Over the SetNetGo Selection Box

Hover over the selection box to reveal its boundaries. (See the cursor in the preceding figure.)

**NOTE:** It is not necessary to enable (check) the checkbox within the SetNetGo selection box. The checkbox determines whether SetNetGo starts automatically when you open MobilePlanner.

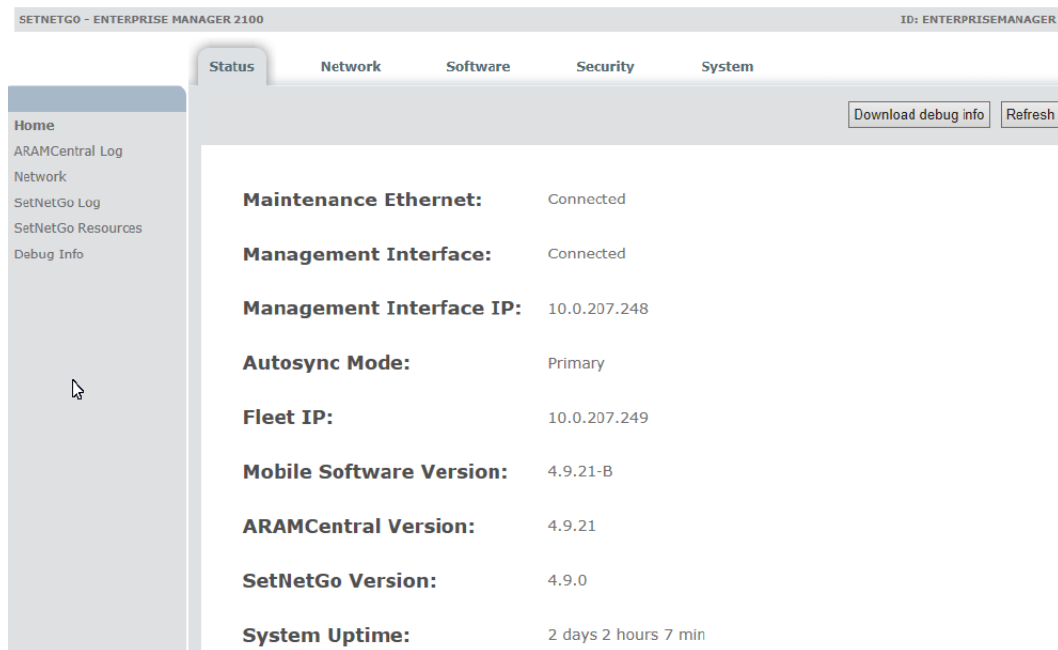

Figure 5-2. SetNetGo Interface—Status Tab, Home Screen

This screen provides an overview of link status, IP addresses, and installed software versions.

## 5.4 Configure Management Interface Network Settings

To configure the Management Network, you require:

- A dedicated static IP address. (Do not use 1.2.3.4. That address is permanently assigned to the Maintenance Ethernet port.)
- The subnet mask for the Management network.
- The IP address of the network Gateway.

- If there are other devices in the network that communicate with the fleet, you require the IP address of the network domain (DNS) server, so that the Enterprise Manager appliance can resolve all IP addresses.

Configure the Management Interface network connections as follows:

1. In the SetNetGo web interface, click the **Network Tab**.
2. Click **Management Interface** and enter the:
  - a. IP address.
  - b. Subnet mask.
  - c. Network Gateway IP address (typically a router).
3. Enter the IP address of your Domain Name Server (DNS), if required for devices other than the appliance and the fleet. Otherwise, leave it as 0.0.0.0.
4. Click **Apply**.

A message dialog informs you of the status of the change, and whether there is any affect on operations such as a restart or a time delay before the change takes effect.

## 5.5 Configure the Fleet Interface Network Settings

To configure the Fleet Interface, you require:

- A dedicated static IP address. Do not use 1.2.3.4. That address is permanently assigned to the Maintenance Ethernet port.
- The subnet mask for the network that your Fleet will use.
- The IP address of the network Gateway

Configure the Fleet Interface network connections as follows:

1. In the SetNetGo web interface, click the **Network Tab**.
2. Click **Fleet Interface** and enter the:
  - a. IP address.
  - b. Subnet mask.
  - c. Network Gateway IP address (typically a router).
3. Click **Apply**.

A message dialog informs you of the status of the change, and whether there is any affect on operations such as a restart or a time delay before the change takes effect.

## 5.6 Use NTP to Synchronize Enterprise Manager 2100 Time

You can either specify the system time manually or configure the Enterprise Manager appliance to synchronize Network Time Protocol (NTP).

When you use NTP:

- The Enterprise Manager appliance synchronizes its clock with NTP as a client of the NTP server.
- Fleet AIVs synchronize their clocks with the Enterprise Manager appliance, regardless of their time settings. Even if you configure a fleet AIV to use NTP, it ignores the NTP settings and synchronizes its clock only with the Enterprise Manager appliance.

To set the date and time manually:

1. Open SetNetGo and click the **System** tab.
2. Select Date/Time.
3. Set the system clock manually by typing in the **Time** and **Date** fields.
4. Click **Set time/date**.

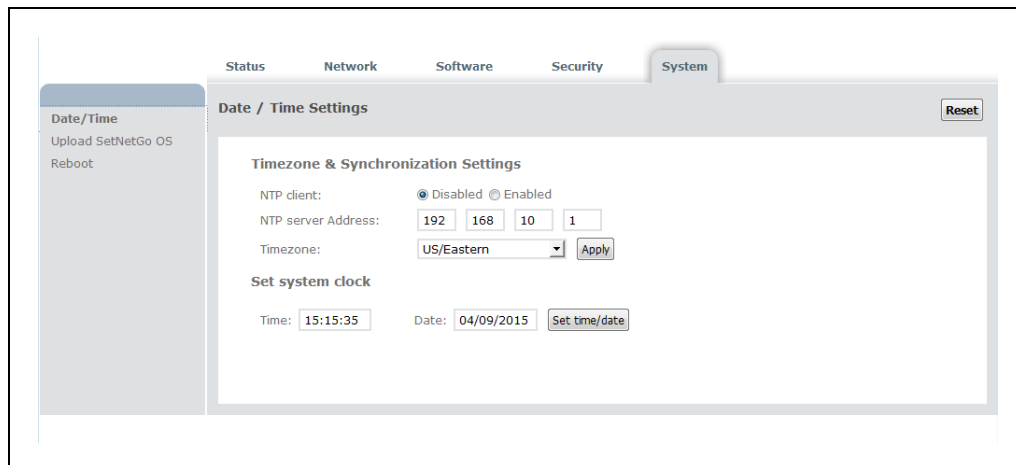

Figure 5-3. Date and Time Settings

To use an NTP server:

1. Open SetNetGo and click the **System** tab.
2. Select Date/Time.
3. Click the **Enabled** button next to NTP client.
4. Enter the IP address of the NTP server.
5. Select your time zone from the Timezone pull-down menu.
6. Click **Apply**.

It might take a few minutes for all AIVs in the fleet to update their internal clocks.

## 5.7 Enabling the ARCL Server

The ARCL server enables automation systems such as WMS, MES or robot control application to communicate with the Enterprise Manager 2100 through a text-based TCP port. For more information about ARCL, see: Software Supplied with the Enterprise Manager 2100 Systems.

Use MobilePlanner to manually enable ARCL as follows:

1. From MobilePlanner, Config select **Robot Interface** and then **ARCL server setup**.

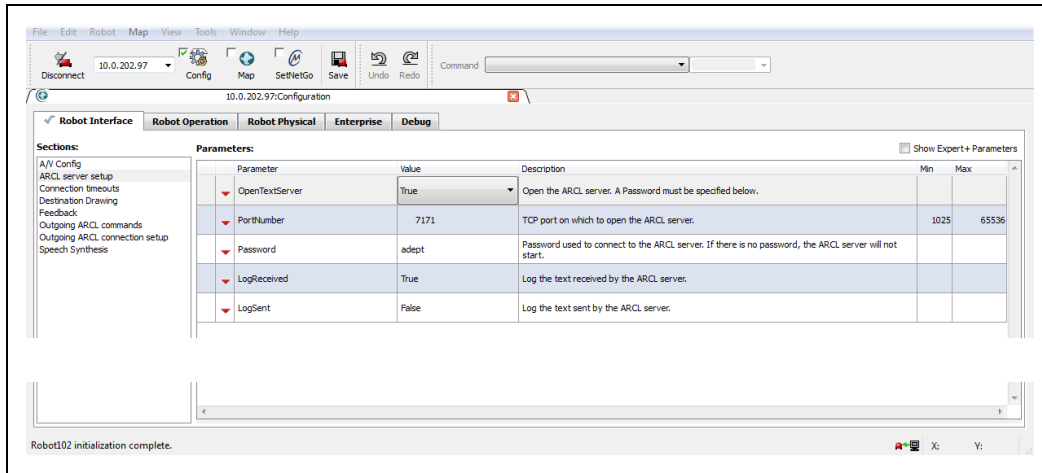

2. In the OpenTextServer field, use the drop-down box to select True.  
The default port is 7171.
3. Enter a password in the Password field.
4. Click Save.

## 5.8 Configure Each AIV to Connect to the Enterprise Manager

Before you can use the Enterprise Manager appliance to manage AIVs, you must configure each AIV to connect to the appliance. To do so, you must connect to each AIV.

When an AIV connects to the appliance, the Mobile Robot Software Suite overwrites the AIV's configuration parameters with Fleet parameters.

**IMPORTANT:** If you have not previously used the Mobile Robot Software Suite, review the Mobile Robot Software Suite User's Guide before you proceed to connect an AIV to the Enterprise Manager 2100.

### AIV Configuration Settings

To connect an AIV to the Enterprise Manager 2100 :

1. Launch MobilePlanner on your client PC and connect to the AIV's IP address.
2. Open the **Config** tab.

3. Check **Expert+ Parameters** to show the advanced configuration parameters.
4. From MobilePlanner, Config select **Enterprise** and then **Enterprise Manager Connection**.

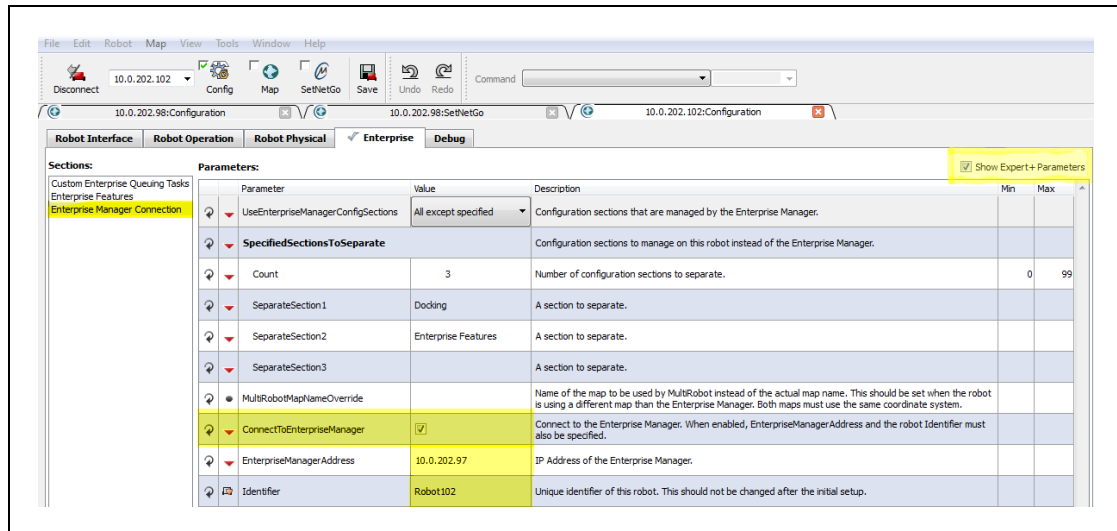

Figure 5-4. Enterprise Manager Connection Screen

5. Check the **ConnectToEnterpriseManager** checkbox.
6. Enter the IP address of the Enterprise Manager 2100 appliance in the **EnterpriseManagerAddress** field.

**NOTE:** This is the Fleet IP address, not the Management IP address of the Enterprise Manager appliance.

7. Enter an identifier in the **Identifier** field. You must use unique identifiers for each AIV. Do not change this identifier after initial setup.

Repeat these steps for each AIV that you want to add to the fleet controlled by this Enterprise Manager appliance.

## Fleet-Level Settings

From MobilePlanner, Config, on the Enterprise Manager 2100:

1. Select **Enterprise** and then **Enterprise Features**.
2. Check the **EnterpriseManagerGatherScans** box.

This enables the Mobile Robot Software Suite to gather any scan files created by the AIVs.

3. Back up (copy) any required maps to a storage location.
4. [OPTIONAL] Check **DeleteUnusedMaps** to permanently delete unnecessary map files from each AIV.

## 5.9 Add a Secondary Appliance for AutoSync

Install an optional Secondary Enterprise Manager appliance to provide redundancy for the Primary appliance.

You can auto-synchronize (Autosync) a Secondary appliance to a Primary appliance, enabling faster recovery should the Primary appliance fail for any reason.

The Autosync feature copies Fleet data from the Primary Appliance to the Secondary Appliance. This data includes:

- The central configuration for AIVs.
- The workspace map.
- Payload information.
- The Pending job queue.

To make sure that synchronization persists, Autosync maintains a constant *heartbeat* signal on the network between appliances. If an appliance fails to respond, the lack of a response indicates a possible failure of the appliance, or of network communications between the appliances. An error message notifies you of the failure so that you can diagnose and correct the problem.

You use the SetNetGo Web interface to configure Autosync, which involves specifying an authentication key to join two appliances into a pair and establish their autosync roles.

Setting up an optional Secondary appliance is described in Installation on page 21 and Configuration on page 45.

## 5.10 Configure a Secondary Appliance and Autosync

The default (shipped) configuration for an Enterprise Manager 2100 is for Primary appliance operation. To create an Autosync pair, you use SetNetGo to configure the existing Primary to communicate with the Secondary. The paired appliances then function as follows:

- The Primary unit is a fully-functional Enterprise Manager appliance, running the Mobile Robot Software Suite and actively controlling the fleet.
- The Secondary unit is powered on, with its Web interface accessible to the Primary unit. However, the Mobile Robot Software Suite is inactive on the Secondary unit, and it is inaccessible from MobilePlanner or AIVs.

The Primary appliance has two active IP addresses, while the Secondary has only one active IP address.

This release supports mixed model EM2100 and EM1100 configurations, but you must use the EM1100 **only** as a Secondary appliance. For more information, see: Supported Enterprise Manager 2100 Deployments on page 14.

## EM2100-Only Autosync – Ethernet Cabling

Figure 5-5. shows the physical connection of Ethernet cables to the appliances.

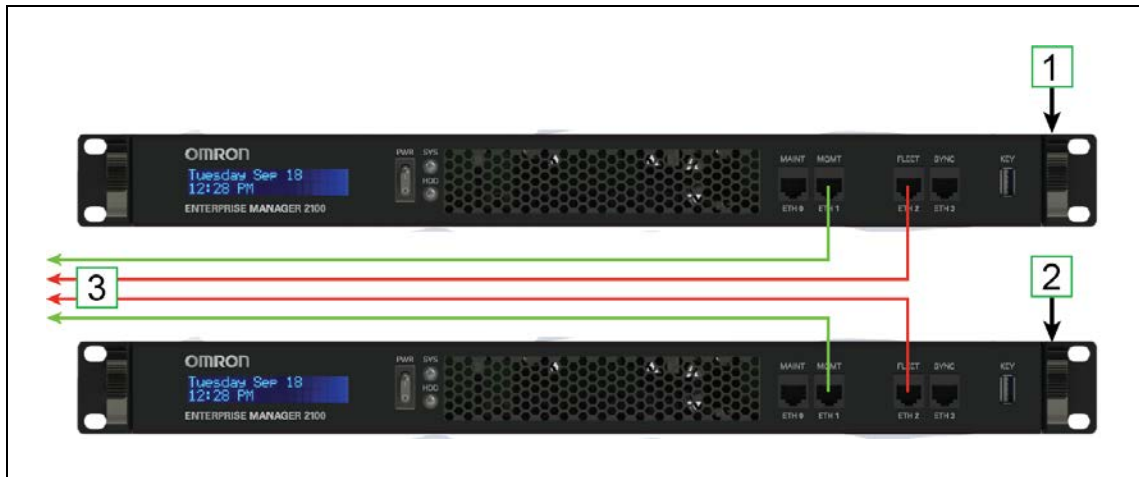

Figure 5-5. Cabling for an EM2100-Only Autosync Configuration.

| Callout | Description   |
|---------|---|
| 1       | EM2100 configured as a Primary appliance.   |
| 2       | EM2100 configured as a Secondary appliance.   |
| 3       | Cat-V Ethernet cables to the LAN switch : <ul style="list-style-type: none"> <li>• Primary and Secondary MGMT ETH1</li> <li>• Primary and Secondary FLEET ETH2</li> </ul> |

## EM2100 and EM1100 Autosync – Ethernet Cabling

Figure 5-6. shows the physical connection of cables to the appliances.

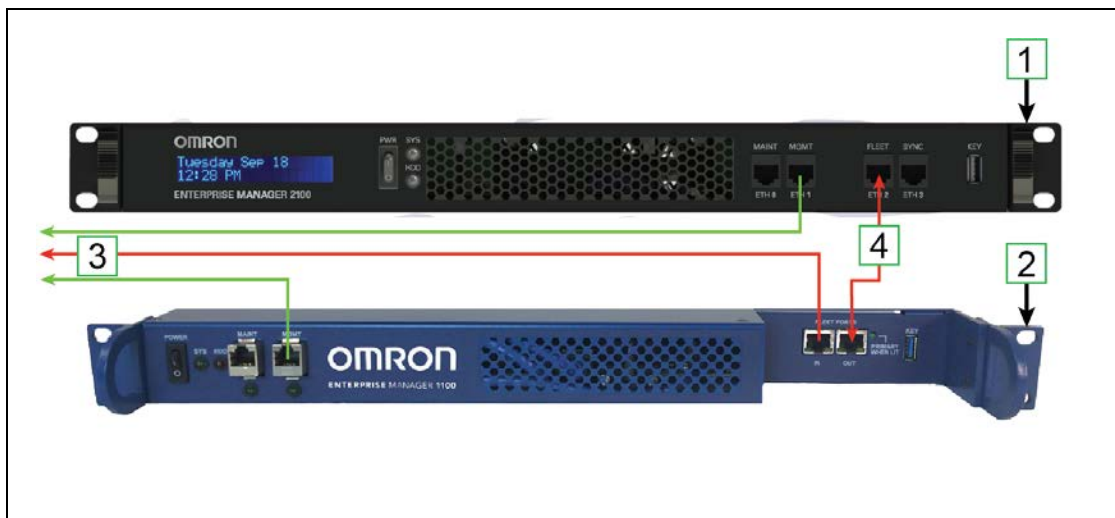

Figure 5-6. Cabling for an EM2100 and EM1100 Autosync Configuration.

| Callout | Description   |
|---------|---|
| 1       | EM2100 configured as a Primary appliance.   |
| 2       | EM1100 configured as a Secondary appliance.   |
| 3       | Cat-V Ethernet cables to the LAN switch: <ul style="list-style-type: none"> <li>• Primary MGMT</li> <li>• Secondary FLEET PORTS IN</li> <li>• Secondary MGMT</li> </ul>                 |
| 4       | Appliance interconnection: <ul style="list-style-type: none"> <li>• From the FLEET (ETH2) connector of the EM2100.</li> <li>• To the FLEET PORTS IN connector of the EM1100.</li> </ul> |

## Tasks in Autosync Setup

Before you set up Autosync, make sure that you have:

- Installed the Primary appliance and connected it to the network.
- Configured the Maintenance Ethernet interface on the Primary appliance.
- Physically installed the Secondary appliance hardware, as described in: Installing a Secondary Appliance on page 34.

The tasks required to set up autosync between a Primary and Secondary appliance are:

- Configure the Primary appliance with a Fleet IP Address.
- Enter the Secondary appliance IP Address in the Primary appliance.
- Generate and Download the Primary key (to your PC).
- Set the Secondary appliance Autosync role to Secondary.
- Upload the Primary key to the Secondary appliance.

## Configure the Primary Appliance

Do this only if you have two Enterprise Manager appliances, and you want to configure one as a Primary Autosync appliance. You must first configure the Management and Fleet networks and cable the appliances. Primary is the default role for an Appliance.

1. In the SetNetGo web interface, click the **Software** tab, then **Autosync**.
2. Set the Autosync role to **Primary**.
3. Enter the IP Address of the Secondary appliance.
4. Click **Generate New Key** to create an SSL key, or **Download Existing Key**, if you previously created an SSL key.
5. You are prompted for a location to save the key file. Save the key locally on your PC, so you can later upload it to the Secondary appliance.
6. Enter a location (path) where you want to save the file.



7. A warning message indicates the pending disconnection of AIVs and clients. Click **Ok**.

Uploading the SSL key to the Secondary appliance grants permission for the Primary to perform RPC calls required for synchronization.

## Configure the Secondary Appliance

Do this only if you have two Enterprise Manager appliances, and you want to configure one as a Secondary Autosync appliance. You must first:

- Configure the Management and Fleet networks and cable the appliances.
  - Configure a Primary appliance.
1. From SetNetGo on the Secondary appliance, select **Software** and then **Autosync**.
  2. Select **Secondary** for the Autosync role field.
  3. Click **Apply**.

A warning message indicates that you must reconfigure AIVs to user the new IP address. Click **Ok**.

4. Click **Choose File** to select the Primary SSL key from your PC.  
Enter the name and path of the file to upload the key from the PC.
5. Click **Upload**.

**NOTE:** Although the **Fleet Interface** settings are saved for the Secondary appliance, the interface is inaccessible.

When the connection is complete, the Primary and Secondary appliances show a Current Status of *active*.

## 5.11 Customize Each Fleet AIV

Use MobilePlanner, Config Software to set the mode for docking station for each AIV.

Be aware that docking behavior is also affected by other parameters such as parameters that control failed docking attempts. For example, if an AIV fails to dock at an assigned dock (perhaps because it is blocked) and the failure occurs three times, it ignores that docking station for 60 minutes.

*Available* docking stations are valid recharging locations that are:

- Unoccupied by another AIV.
- Not currently ignored by the AIV (because of previous failed attempts to dock).

### Docking Station Assignment

There are three modes that you can use to specify an AIV's docking and battery charging behavior. To access the relevant docking parameters:

1. Open MobilePlanner connect to the AIV's IP Address.
2. Navigate to **Robot Operation** and then **Docking**.
3. Enable **Show Expert+ Parameters**.

### Default Mode

When an AIV requires a recharge, it uses the nearest *available* docking station.

1. Leave **PreferredDock** at the default setting (no value specified).
2. Set **OnlyUsePreferredDock** to False.

### Mixed Mode

In mixed mode, the AIV uses a preferred docking station only if that docking station is *available* . If the preferred option fails, the AIV searches for an alternate docking station.

1. Select **PreferredDock**, and enter the name of the docking station that is preferred for the AIV.
2. Set **OnlyUsePreferredDock** to False.

### Separate Docking Stations

In this mode, each AIV is assigned its own docking station.

1. Select **PreferredDock**, and enter the name of the docking station that is preferred for the AIV.
2. Set **OnlyUsePreferredDock** to True.

### Distinct Speech Synthesis Voices

By default, the AIV voice parameters are set at the Enterprise Manager level, and all AIVs use the same voice.

If desired, each or some AIVs can have independently configured speech-synthesis settings. This gives you the ability to give every or some AIVs a distinctive voice.

To enable different voices for each AIV:

1. From MobilePlanner, Config select **Enterprise** and then **Enterprise Config Management**.
2. Under SectionsToSeparate, increment Count if there are no empty SeparateSectionX rows, where 'X' is a number, with an empty Value field.
3. Enter the string "Speech Synthesis" in an empty Value field.
4. Click Save.

The Speech Synthesis section of parameters are now displayed on each AIV, and any voice that you set on an AIV is controlled by the AIV, rather than overwritten by the Mobile Robot Software Suite.

To enable different voices for only some AIVs, use the MobilePlanner software to connect to each of those specific AIVs and do the following:

1. Select **Enterprise** and then **Enterprise Manager Connection**.
2. Use the drop-down arrow to change the Value field of UseEnterpriseManagerConfigSections from "All" to "All except specified".
3. If there are no SeparateSectionX rows, where 'X' is a number, with an empty Value field, increment the Count parameter.

The Count and SeparateSectionX parameters are not displayed if UseEnterpriseManagerConfigSections is set to All.

4. Add the string "Speech Synthesis" to an empty SeparateSectionX Value field.

## 5.12 Call Buttons

If installed, you can use the call button option to request an AIV from a remote location.

Pressing a call button sends a request to the Enterprise Manager 2100 system, requesting it to send an AIV to the call button's assigned goal. The Enterprise Manager 2100 responds by selecting an available AIV, and then assigning the call button's goal to that AIV.

The *LD Platform Peripherals Guide* describes call buttons in more detail.



# Chapter 6: Operation

This chapter describes how to operate the Enterprise Manager appliance. It includes the following topics.

|   |    |
|---|----|
| <a href="#">6.1 Turn Enterprise Manager 2100 Power ON and OFF</a>                       | 61 |
| <a href="#">6.2 Generate a Workspace Map for Your Fleet</a>                             | 64 |
| <a href="#">6.3 Managing Queuing</a>  | 64 |
| <a href="#">6.4 Update the ARAMCentral Software</a>                                     | 71 |
| <a href="#">6.5 Enterprise Manager 2100 Autosync Operation</a>                          | 71 |
| <a href="#">6.6 Remove and Replace Enterprise Manager 2100 Appliances from Autosync</a> | 72 |
| <a href="#">6.7 What to do if an EM2100 Primary Appliance Fails</a>                     | 74 |
| <a href="#">6.8 What to do if an EM1100 Autosync Appliance Fails</a>                    | 74 |
| <a href="#">6.9 Troubleshooting</a>   | 76 |

Be aware that before you proceed, you must complete the steps in Installation on page 21 and Configuration on page 45.

## 6.1 Turn Enterprise Manager 2100 Power ON and OFF

Use the front momentary power switch to control AC power. The rear switch should remain on unless you are uninstalling the appliance.

### Safe Power On

Use the following power on procedure only if you are sure that the environment was safely shut down and is ready to restart. Otherwise, see: Power On After a Hard Shutdown.

1. Press and hold the front Power switch to power-on the Enterprise Manager appliance. The power LED illuminates immediately.
2. Observe the boot message sequence in the display panel.
3. If there are no boot errors, the boot sequence can take up to two minutes, typically less.

### Soft Shutdown and Power Off

The following procedure initiates a soft shutdown (preferred), where the operating system runs through a graceful shutdown procedure. For emergency shut down, see Hard Shutdown and Power Off.

1. Press and release the front power switch to start the shutdown sequence for the Enterprise Manager appliance.
2. Wait for the Appliance to beep three times.
3. Observe the shutdown messages on the control panel.

4. The power LED goes out when the sequence is complete.
5. The shutdown takes up to a minute, though typically less.

### Hard Shutdown and Power Off

The following procedure initiates a hard shutdown (emergency shut down), where the operating system terminates immediately. Be aware that this procedure terminates AIV jobs in progress, regardless of their status.

1. Press and hold the front power switch for at least four seconds.
2. Wait for the Appliance to beep three times.
3. Observe the shutdown messages on the control panel.
4. The power LED goes out when the sequence is complete.
5. The shutdown is immediate.

Do not power-on the Enterprise Manager appliance until you have resolved all problems in the work environment. Then, follow the procedure described in: Power On After a Hard Shutdown.

### Power On After a Hard Shutdown

If you previously powered off an Enterprise Manager appliance with an emergency (hard) shutdown, your work environment might be in an indeterminate state. Before you power on:

1. Make sure that all AIVs:
  - a. Have charged batteries.
  - b. Are operational, with no error or no E-stop conditions.
  - c. Are in the correct locations and properly localized.
2. Check the operational status of any site-specific automated machinery (such as conveyors) and any in-transit payloads.
3. Use MobilePlanner to determine the status of jobs-in-progress at the time of the emergency shut down. Re-queue jobs as necessary.
4. Follow the power-on steps described in: Safe Power On on page 61.

### Affect of Power Interruptions on an Enterprise Manager 2100

Omron Adept Technologies, Inc. recommends that you always use an uninterruptible power supply (UPS) to mitigate the affect of a power interruption. If you use two appliances in an Autosync configuration for operational redundancy, connect each appliance to separate power circuits and UPS devices.

### Power Interruptions on a Standalone Enterprise Manager 2100

If there is an interruption to the power supply for any reason or duration, a standalone Enterprise Manager appliance automatically returns to its previous power state.

- A standalone appliance that was shut down and powered off when the interruption occurred remains shut down after you restore power.
- A standalone appliance that was powered on when the interruption occurred restarts automatically after you restore power.

After recovery from a power interruption, the Enterprise Manager appliance saves its job queue status and recovers the queue automatically after it restarts following a power failure. This does not apply to an operator-initiated emergency power off. See: Power On After a Hard Shutdown on page 62.

## Power Interruptions on an Autosync Enterprise Manager 2100

This section assumes that you configured Autosync on two appliances and connected each appliance to separate power circuits for redundancy. Providing that only one circuit was affected, one appliance should remain operating normally during the power interruption. The sequence of events and method of recover depends on which appliance is affected:

- A power interruption on the Primary appliance results in a loss of connectivity with AIVs and MobilePlanner. You should:
  - Determine whether the problem is a power outage or a loss of network connectivity.
  - Manually reconfigure the Secondary appliance to become the Primary Appliance. Autosync status is now disabled.
  - Verify that MobilePlanner and AIVs reconnect to the Fleet IP address.
  - Review the job queue status in MobilePlanner and verify the status of AIVs to make sure that no jobs are incomplete.
  - Revert the current Primary appliance to its previous role as a Secondary appliance.
  - Restore power to the former Primary appliance, which causes a temporary loss of connectivity with AIVs and MobilePlanner.
  - Review the job queue status in MobilePlanner and verify the status of AIVs to make sure that no jobs are incomplete.
- A power interruption on the Secondary appliance results in no loss of connectivity with AIVs and MobilePlanner. You should:
  - Verify that MobilePlanner and AIVs reconnect to the Fleet IP address.
  - Review the job queue status in MobilePlanner and verify the status of AIVs to make sure that no jobs are incomplete.
  - Restore power to the Secondary appliance. Fleet operations should be unaffected.

If both Autosync appliances are affected by a power interruption, they both behave as described in: Power Interruptions on a Standalone Enterprise Manager 2100 on page 62:

- All fleet operations are terminated during the power interruption.
- Normal Active Autosync operation resumes automatically after you restore power to both appliances.

- The Primary Enterprise Manager appliance saves its job queue status and recovers the queue automatically after it restarts.

Automatic recovery of operations might not apply to an operator-initiated emergency power-off on the Secondary appliance. See: Power On After a Hard Shutdown on page 62.

## 6.2 Generate a Workspace Map for Your Fleet

Creating and sharing a workspace map for your fleet requires the MobilePlanner software, running on a user-supplied PC. The *Mobile Robot Software Suite User's Guide* describes the software and process for generating the map.

Briefly, the tasks involved are:

- Use a single AIV in manual drive mode to Generate a map.
- Upload the generated map to the Enterprise Manager appliance and make it the current map.
- The map is downloaded automatically to every AIV in the fleet.

The Enterprise Manager appliance communicates with each AIV individually, rather than doing a broadcast. In addition to maps, the Enterprise Manager appliance downloads fleet-common configuration parameters to each AIV.

**NOTE:** If you are doing a trial with a single AIV, save the data and configuration to your PC, and then download from your PC to the Enterprise Manager appliance when you are confident that it is accurate.

## 6.3 Managing Queuing

This section describes how to manage AIV job queues.

### Queuing and Job Definitions

- **Job** - a single command issued to the Enterprise Manager, consisting of one or more related, ordered moves (job segments). Each job has a unique job ID.
- **Job segment** - one discreet move assigned to a AIV. A segment consists of a single goal name, and you can define it as either a PICKUP or a DROPOFF job segment. The goals might have tasks that are assigned to the AIV, which count as part of the job segment. Each job segment has a unique ID.
- **Queue** - a collection of requested jobs and job segments, stored on the Enterprise Manager 2100, that are either assigned or waiting to be assigned to AIVs.
- **Assigned Job** - a job segment becomes assigned after the Enterprise Manager has allocated an AIV to perform the job. A job segment transitions from Pending to InProgress after assignment.
- **Pickup** - a job segment that ends at a goal so that a payload is loaded onto the AIV. If the first segment of a job is a PICKUP, then the Enterprise Manager 2100 assigns this job to whichever AIV it decides is most appropriate.
- **Dropoff** - a job segment that ends at a goal so that a payload is removed from the AIV.



A DROPOFF segment is handled only by the required AIV.

- **Required Robot** - certain job segments are serviced only by a specific AIV. For example, the DROPOFF segment of a PICKUP-DROPOFF job must be handled by the same AIV that performed the pickup. Thus, whichever AIV handles the initial PICKUP job is the *required robot* for the DROPOFF.

The Enterprise Manager appliance enables you to queue jobs. It can accept multiple requests for AIVs, and then select the best AIV for each job, based on the criteria you specify. It sends the selected AIV to the requested location. It tracks the status of jobs and AIVs as they perform their assigned jobs.

The requests that are queued include:

- a request for any AIV to be sent for a pickup (PICKUP) for which the delivery destination (DROPOFF) is not yet known (queuePickup ARCL command).

It is assumed that the delivery destination is communicated directly to the AIV that responds, prior to completion of the pickup.

- a request that a specific AIV drive to a particular goal (DROPOFF) (queueDropoff ARCL command).

This is communicated directly to the AIV, but is queued and tracked by the Enterprise Manager 2100.

- a request that an AIV be sent for a job that has predetermined pickup and dropoff destinations (queuePickupDropoff ARCL command).

To complete the job the AIV requires no further job commands.

The Enterprise Manager 2100 manages jobs associated with either a PICKUP or a DROPOFF goal. Any AIV tasks that are associated with the goals are executed at the proper times, though they are not managed as separate jobs in the queue.

Omron Adept Technologies, Inc. recommends that you use the task *pause* when an AIV arrives at its destination, although this is not managed by queue. Use the associated *pauseTaskCancel* task to signal dismissal after the AIV is loaded or unloaded. You can trigger this task either by a manually-activated button, or by an automated system event.

When the Enterprise Manager appliance receives a request, it does the following:

1. Queuing

- The request is assigned a default priority (unless another priority is specified) and put into the queue.

Pickup/Dropoff requests are entered as two separate jobs - a pickup, and a dropoff.

Each segment has a unique queue ID, as well as a job ID that tracks the entire pickup/dropoff sequence.

- Queuing enables job cancellation.

### 2. Dispatching

- An AIV is selected, based on the criteria you specified.
- The AIV is sent to the goal.

### 3. Tracking

- The queuing manager monitors the AIV and job status.
- The job is deleted from the queue when the request is satisfied, or is requeued if the job fails.

Jobs might be in one of six states:

- Pending - new, unassigned jobs.
- In Progress - jobs that are being actively processed.
- Completed - jobs that were successfully processed.
- Failed - jobs that failed, due to reasons such as a blocked path or E-Stop.
- Canceled - jobs that were manually canceled with the `queueCancel` command
- Interrupted - jobs that have been interrupted by an Operator manually controlling the AIV. These jobs are reassigned after a brief pause.

## Queuing Examples

The following flowcharts represent sample usage scenarios, and require some application-layer support to fully implement.

The following flowchart illustrates a simple pickup and delivery cycle. Other factors, such as state of charge, can alter this flow.

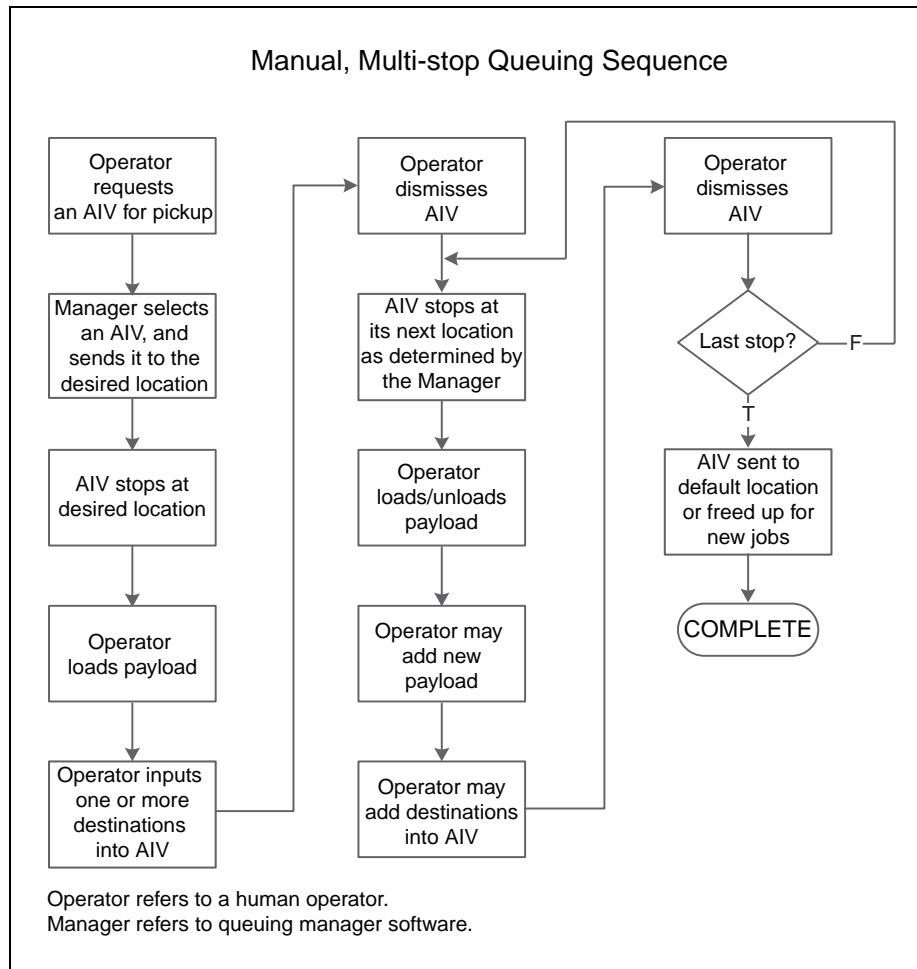

Figure 6-1. Manual Queuing Cycle

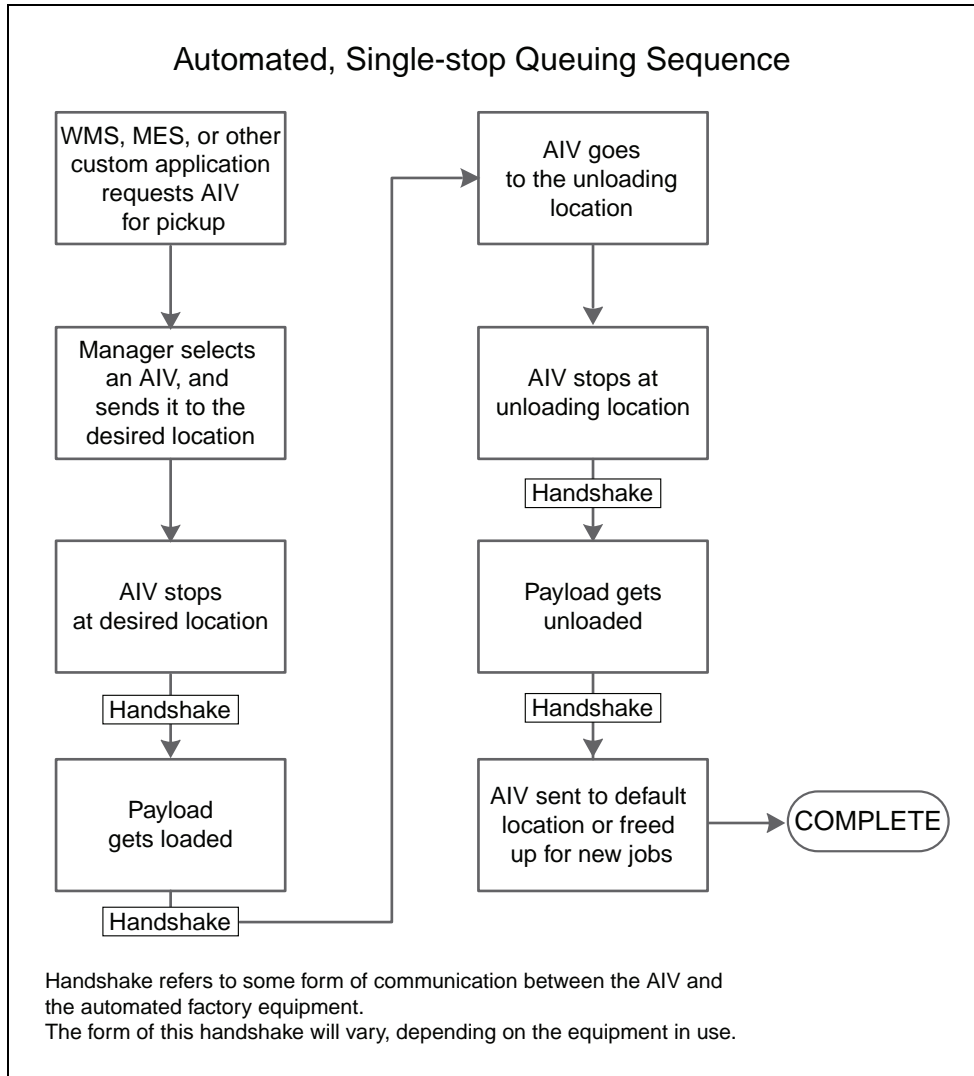

Figure 6-2. Fully-automated Queuing Cycle

## Queuing Parameters

You configure various parameters to specify how the Enterprise Manager 2100 processes queued requests. You set most of these parameters from within MobilePlanner. See the *Mobile Robot Software Suite User's Guide* for information about using the MobilePlanner software.

To access these parameters from Enterprise Manager 2100:

1. In MobilePlanner, open the **Config** tab.
2. Select **Robot Operation** and then **Queuing Manager**.

The parameters that control the way that the Enterprise Manager 2100 handles queuing are:

- **IdleTimeUntilResume** - Number of minutes to wait, after an AIV becomes available, before automatically resuming an interrupted job.

If an AIV has recently booted , or recently operated manually, then this is the number of minutes that the queuing manager waits before assigning any new jobs to this AIV. The parameter supports decimal numbers (such as 0.1 minutes for 6 seconds).

- **LowStateOfCharge** - This is the state-of-charge (SOC) below which the queuing manager no longer assigns new jobs to that AIV. If an AIV is below this state of charge when it completes a job, it is sent to dock.

The AIV continues its assigned jobs until it reaches the SOC limit set by the value of the **AutoDockStateOfCharge** parameter. Consider the following constraints:

- An AIV drives to a docking station any time that its state of charge falls below the limit set for **AutoDockStateOfCharge** even if it is performing a job. This is an AIV-level parameter, not visible or settable on the Enterprise Manager 2100.
  - Omron Adept Technologies, Inc.recommends that at least a 10% difference between **LowStateOfCharge** and **AutoDockStateOfCharge**, to make sure that the AIV does not drive to a docking station while performing a job.
  - An AIV docks only if you set **AutoDock** to True.
- **DefaultDropoffPriority** - The default priority to use in all dropoff requests to the queuing manager.
  - **DefaultPickupPriority** - The default priority to use in all pickup requests to the queuing manager.
  - **DeleteCompletedItemsMinutes** - Number of minutes to keep completed jobs.
  - **MaxNumberOfCompletedItems** - Maximum number of completed jobs to keep.
  - **EnableParking** - Sends the AIV to a standby goal after it completes its jobs.

The following screen shows configuration parameters for queuing:

| Parameters for 'Queuing Manager': |       |   |     |        |         |  |
|-----------------------------------|-------|---|-----|--------|---------|--|
| Parameter                         | Value | Description   | Min | Max    | Default |  |
| EnableParking                     | True  | When enabled, robots are sent to parking goals after they complete their job assignments. Applicable only when Map Features > Standby is enabled.   |     |        |         |  |
| InterruptParkingForNewJobs        | True  | When enabled, robots that are en route to a parking goal can be interrupted and assigned new jobs. Otherwise, the robots must reach the parking goal before they can be assigned new jobs.                            |     |        |         |  |
| IdleTimeUntilResume               | 1.0   | Number of minutes to wait after a robot becomes available before automatically resuming an interrupted item. Fractional values are allowed.   | 0.1 |        |         |  |
| ParkLowStateOfCharge              | 40.0  | State of charge (in %) that is considered too low for parking by the Queuing Manager. If the battery is below this level when the robot completes a job, then the robot will dock instead of going to a parking goal. | 0.0 | 100.0  |         |  |
| LowStateOfCharge                  | 20.0  | State of charge (in %) that is considered low by the Queuing Manager. If the battery is below this level when the robot completes a job, then the robot will be sent to the dock.                                     | 0.0 | 100.0  |         |  |
| DefaultDropoffPriority            | 20    | Default priority to use in all DROPOFF requests to the Queuing Manager. Larger numbers have higher priority.  | 0   | 200000 |         |  |
| DefaultPickupPriority             | 10    | Default priority to use in all PICKUP requests to the Queuing Manager. Larger numbers have higher priority.   | 0   | 200000 |         |  |
| DeleteCompletedItemsMinutes       | 60    | Number of minutes to maintain a record of completed Queuing Manager job segments.   | 1   | 500000 |         |  |
| MaxNumberOfCompletedItems         | 100   | Maximum number of completed Queuing Manager job segments to keep.   | 1   | 500000 |         |  |
| QueueFailedJobsInFront            | False | When enabled, failed jobs will be queued using time and priority. When disabled (the default), failed jobs will be queued using priority only.  |     |        |         |  |

Figure 6-3. Queuing Manager Parameters

The following list shows the commands available for queuing.

- CancelQueueId
- CancelQueueJobId
- DisplayDeliveryQueue - Presents a pop-up window showing the delivery queue.
- DisplayShowRobot - Presents a pop-up window that shows the status of all AIVs in the fleet.
- QueuingLog
- QueuingStats

To find these parameters in MobilePlanner, click **Config** and **Robot Operation** and then **Queuing Manager**.

**NOTE:** A red plus sign (+) preceding a command indicates that it accepts an argument.

## Manually Clearing (Flushing) the Entire Queue

Use the ARAMCentral software to set the configuration parameters that apply to your fleet. For some parameters, you must also make corresponding changes to the configuration on the individual AIVs. Use ARAMCentral parameters only in limited circumstances, typically when working with your local Omron support.

To clear the entire queue, temporarily add a special startup argument to ARAMCentral. The following procedure clears the queue:

1. In MobilePlanner select the **Config** tab.
2. Select **Enterprise** and then **Enterprise Config Management**.
3. Under SectionsToSeparate, increment Count if there are no empty SeparateSectionX rows, where 'X' is a number, with an empty Value fields.
4. Enter the string "EnterpriseManagerFlush" in an empty Value field.

5. Click **Save**.
6. Wait for the ARAMCentral software to restart.
7. Use the command in MobilePlanner to verify that the queue is cleared.
  - a. Select EnterpriseManagerDisplayDeliveryQueue from the Command field drop-down list.
  - b. Click the **Command** icon.The queue should now be empty.
8. Reconnect to the MobilePlanner software, and remove the "EnterpriseManagerFlush" entry.
9. Click **Save**.
10. Wait for the ARAMCentral software to restart.

## 6.4 Update the ARAMCentral Software

You can update the ARAMCentral version on the Enterprise Manager appliance from within SetNetGo. This is part of the Mobile Software suite.

To update the ARAMCentral package:

1. Open SetNetGo.
2. Select **Software** and then **Manage Installed Software**.
3. Click **Browse...** to navigate to and select the software update file.
4. Click **Upload** to upload the Mobile Software suite to the Enterprise Manager appliance. This uploads the ARAMCentral software.

Use the **View Release Notes** option to see changes and features that are included in the update.

### Restarting ARAMCentral

Changes to the Enterprise Manager appliance ARAMCentral might cause it to automatically stop and restart (depending on the type of change that you make). You can also use SetNetGo to force ARAMCentral to restart as follows:

1. Open SetNetGo.
2. Select **Software** and then **Manage Installed Software**.
3. Click **Restart**.

## 6.5 Enterprise Manager 2100 Autosync Operation

Autosync provides operational redundancy if a problem occurs with the Primary appliance. During normal Autosync operation, you will observe changes only when either the Primary or Secondary appliance stops operating. This might be caused by a temporary power loss or an

internal hardware component failure such as a disk drive crash. If both appliances are affected, all fleet operations terminate.

**NOTE:** The Enterprise Manager 2100 appliance contains no user-serviceable components. Contact your local Omron support if a catastrophic hardware failure occurs. See: How to Get Help on page 15.

## 6.6 Remove and Replace Enterprise Manager 2100 Appliances from Autosync

This section describes how to remove an appliance from an Autosync configuration.

### Remove a Primary Appliance from Autosync

You might need to remove a Primary appliance from an Autosync configuration while maintaining fleet operations. For example, if the Primary appliance is generating errors that indicate a potential failure or degraded performance. This procedure assumes that you do not make any changes to the software and data stored on the removed appliance.

To safely remove an Enterprise Manager 2100 Primary appliance from an Autosync configuration, you must promote the Secondary appliance to the Primary role as shown in 6.6 You can then safely remove the Primary as follows:

1. Verify that fleet operations are normal and job processing is on schedule.
2. Reconfigure the Primary appliance as a Secondary appliance. See: Configure the Secondary Appliance on page 57.

MobilePlanner and fleet AIVs might lose their network connection to the appliance.

3. Reconfigure the Secondary appliance [2] as the Primary appliance. See: Configure the Primary Appliance on page 56.
4. Power off the Secondary (failing) appliance.
5. The new Primary appliance now indicates that Autosync is disabled (it is now a standalone appliance.)
6. Verify that MobilePlanner can connect to the Fleet IP, that fleet AIV operations resume, and jobs are processed as scheduled.

To restore a removed appliance to its role as Primary appliance, or to replace it with a new appliance:

1. Verify that fleet operations are normal and job processing is on schedule.
2. If you have removed any network cables, replace them as shown in Figure 5-5.
3. Power on the (now Secondary) appliance. (This should not affect fleet operations or Ethernet connections to MobilePlanner and AIVs.)
4. Reconfigure the Primary appliance as a Secondary appliance. See: Configure the Secondary Appliance on page 57.

MobilePlanner and fleet AIVs might lose their network connection to the appliance.



5. Reconfigure the Secondary appliance as the Primary appliance. See: Configure the Primary Appliance on page 56.
6. Both appliances now indicate that Autosync is **Active**.
7. Verify that MobilePlanner can connect to the Fleet IP, that fleet AIV operations resume, and jobs are processed as scheduled.

## Remove a Secondary Appliance from Autosync

You might need to remove a Secondary appliance from an Autosync configuration while maintaining fleet operations. For example, if the Secondary appliance is generating errors that indicate a potential failure or degraded performance. This operation is less disruptive than removing a Primary appliance.

**IMPORTANT:** This procedure assumes that you do not make any changes to the appliance configuration or to the software and data stored on the appliance.

To remove an Enterprise Manager 2100 Secondary appliance from an Autosync configuration:

1. Verify that fleet operations are normal and job processing is on schedule.
2. Power off the Secondary appliance.
3. The Primary appliance now indicates that Autosync is disabled (it is now a standalone appliance.)
4. Verify that MobilePlanner can connect to the Fleet IP, that fleet AIV operations resume, and jobs are processed as scheduled.

To restore a removed Secondary appliance:

1. Verify that fleet operations are normal and job processing is on schedule.
2. If you have removed any network cables, replace them as shown in Figure 5-5.
3. Power on the Secondary appliance. (This should not affect fleet operations or Ethernet connections to MobilePlanner and AIVs.)

Both appliances now indicate that Autosync is **Active**.

4. Verify that MobilePlanner can connect to the Fleet IP, that fleet AIV operations resume, and jobs are processed as scheduled.

## 6.7 What to do if an EM2100 Primary Appliance Fails

This section applies only if you installed a Secondary Enterprise Manager appliance, auto-synchronized with the Primary.

In event of failure:

1. Using the SetNetGo interface, connect to the Management IP address for the Secondary appliance.
2. From SetNetGo on the Secondary appliance, select **Software** and then **Autosync**.
3. Switch the Secondary appliance from Secondary to Primary.  
Use the drop-down arrow in the Autosync role field to select Primary.
4. Click **Apply** or click **Reset** to clear the form and restore its original values.

The AIVs automatically reconnect to the new Primary appliance.

The queue, configuration, and map data on the new Primary is identical to that of the old Primary, prior to failure. Depending on exact network configuration, it takes between 1-3 minutes for AIVs to reconnect and resume operation.

The original (failed) Primary appliance can now be safely removed from the rack without causing disruption to the fleet. The following considerations apply:

- The new Primary operates on the same Fleet IP as the old Primary appliance. Do not reconnect the old Primary to the network without first reconfiguring it. Doing so might cause a network IP conflict.
- The failed Primary has the queue file, which is no longer current. Before putting the failed Primary back into service, you should manually clear the queue. See [Manually Clearing \(Flushing\) the Entire Queue](#) on page 70.

## 6.8 What to do if an EM1100 Autosync Appliance Fails

This section applies only if you have a two EM1100 appliances in an Autosync configuration, and either the Primary or the Secondary fails and you must replace it with an EM2100. In mixed-model configurations, the EM2100 always operates as the Primary appliance, while the EM1100 always operates as the Secondary appliance.

If you have a mixed-model (EM1100 + EM2100) Autosync configuration, it cannot support multiple software versions. Both appliances must run the same version that is running on an EM2100, and you must upgrade the EM1100 to that version.

### Configure an EM1100 to EM2100 Configuration

Use the following procedure to replace a failed EM1100 Appliance with a replacement EM2100.

1. Power off the failed appliance and disconnect its power cable.
2. Remove the networking cables from the failed EM1100 appliance and physically remove it.

3. Install the replacement EM2100 hardware as described in: Installation on page 21.
4. Reconnect the networking cables from the remaining, functioning EM1100 as shown in: EM2100 and EM1100 Autosync — Ethernet Cabling on page 55.
5. Using the SetNetGo interface, connect to the EM1100 Management IP address.
6. Update the software on the EM1100 as described in: Update the ARAMCentral Software on page 71.
7. From SetNetGo on the Secondary appliance, select **Software** and then **Autosync**.
8. If the EM1100 is not already configured as a Secondary appliance, configure it as described in: Configure the Secondary Appliance on page 57.
9. Configure the replacement EM2100 as the Primary appliance as described in: Configure the Primary Appliance on page 56. If not already configured as a Primary, which is the default (shipped) setting.
10. Wait for Autosync to start and for normal operation to resume.

The AIVs automatically reconnect to the new Primary appliance.

The queue, configuration, and map data on the new Primary is identical to that of the old Primary, prior to failure. Depending on exact network configuration, it takes between 1-3 minutes for AIVs to reconnect and resume operation.

You can now safely remove the original (failed) Primary appliance from the rack without causing disruption to the fleet. The following considerations apply:

- The new Primary operates on the same Fleet IP as the old Primary appliance. Do not reconnect the old Primary to the network without first reconfiguring it. Doing so might cause a network IP conflict.
- The failed Primary has the queue file, which is no longer current. Before putting the failed Primary back into service, you should manually clear the queue. See Manually Clearing (Flushing) the Entire Queue on page 70.

## 6.9 Troubleshooting

Use SetNetGo or the command prompt in your Windows client PC to do the following.

| Symptom  | Possible Causes  | Possible Remedies   |
|--|--|---|
| No Power LED<br>Check power source                               | Power or hardware failure  | Verify power cord plugged into working outlet or functional UPS<br>Verify power switch on back of EM is in the ON position<br>Contact your local Omron support  |
| Maintenance network unavailable<br>ping IP 1.2.3.4               | Network failure<br>OS image failure  | Verify PC network settings<br>Verify cable, plugged into MAINT port<br>Contact your local Omron support   |
| Management network unavailable<br>ping the Management IP address | LAN configuration error  | Verify the <b>Management Interface</b> settings in SetNetGo<br>Verify firewall access across network<br>Verify network cable plugged into LAN from MGMT port  |
| Fleet network unavailable<br>ping the Fleet IP address           | LAN configuration error<br>Network cabling error<br>Autosync configuration error             | Verify firewall access across network<br>Single EM (no Autosync): <ul style="list-style-type: none"> <li>• Verify autosync mode set to Primary</li> <li>• Verify proper "Fleet Interface" settings in SetNetGo</li> <li>• Verify the Ethernet cable connections</li> </ul> With Autosync: <ul style="list-style-type: none"> <li>• Verify proper "Fleet Interface" settings on Primary unit in SetNetGo</li> <li>• Verify Autosync mode set to Primary on one EM, and Secondary on the other EM</li> <li>• Verify Ethernet cable connections</li> </ul> |
| Fleet network available, but not functional                      | ARAMCentral configuration error<br>Network permissions error<br>Autosync configuration error | Verify that the Fleet IP address is different than the Management IP address<br>Verify ARAMCentral is running by checking logs in SetNetGo<br>Verify firewall access<br>If using Autosync, verify autosync mode is set to Primary on only one Enterprise Manager  |

| Symptom  | Possible Causes   | Possible Remedies   |
|--|---|---|
| Cannot connect to ARCL port  | ARAMCentral configuration error<br><br>License key error  | Verify ARCL Server is enabled<br><br>Verify firewall access   |
| Can connect with ARCL to Fleet IP address<br><br>No AIVs appear in MobilePlanner | Configuration error on AIV<br><br>WiFi network permissions error<br><br>Software version mismatch | Verify AIVs are configured with "ConnectToEnterpriseManager" and related parameters.<br><br>Verify AIVs are set up on WiFi.<br><br>Verify AIVs have firewall access to access Enterprise Manager appliance from WiFi network<br><br>Verify AIVs are running same MAJOR.MINOR version of software as EM. For best results, install the same Mobile Software suite on all EMs and AIVs. |

If you are requesting help from Omron Adept Technologies, Inc., it is very useful to include a debugInfo file. Instructions for doing so follow.

### Including a debugInfo File with Your Help Request

Use the MobilePlanner SetNetGo interface to retrieve the debugInfo file.

If you are unable to use the MobilePlanner SetNetGo interface:

1. Open a web browser and enter the URL:

`https://<your_EnterpriseManager_IP>`

If you have not set up the Enterprise Manager appliance on the main LAN, then make a direct connection from your PC to the MAINT ETH port.

2. Set the IP address to: 1.2.3.5 and the Subnet Mask to: 255.255.255.0.
3. Using a network patch cable (straight-through), connect the network port of your computer to AIV's maintenance port (MAINT ETH).
4. Open a web browser and enter the URL: `https://1.2.3.4`

In either case, you are requested to confirm security certificates. You should now have the SetNetGo Home window.



1. Select **Status** and then **Debug Info**.
2. Click **Download debug info**.
3. Save the file, and attach it to your support request.

# Chapter 7: Technical Specifications

This chapter provides the technical specifications and physical dimensions of the Enterprise Manager appliance.

## 7.1 Processing Specifications

Table 7-1. Processing Specifications

|                  |                         |
|------------------|-------------------------|
| CPU              | Intel® Xeon® CPU        |
| Memory           | 32 GB DDR3              |
| Operating System | SetNetGo Embedded LINUX |
| Data Storage     | 4 TB                    |

## 7.2 Environmental Specifications

You must ship or store the Enterprise Manager appliance under environmentally-controlled conditions. Refer to the following table.

Table 7-2. Environmental Specifications

|                                     |                              |
|-------------------------------------|------------------------------|
| Operating temperature               | 10 to 35°C (50 to 95°F)      |
| Operating humidity range            | 8 to 90%, non-condensing     |
| Storage and shipment temperature    | -25 to +60°C (-13 to +140°F) |
| Storage and shipment humidity range | 5 to 95%, non-condensing     |
| Chassis protection class            | IP20 (NEMA Type 1)           |

## 7.3 Power Requirements

Table 7-3. Power Specifications

|                                 |                                     |
|---------------------------------|-------------------------------------|
| Input Voltage                   | 100 - 240 VAC, 50/60 Hz             |
| Typical Power Consumption       | 100 W                               |
| Maximum Power Consumption       | 200 W                               |
| Appliance power inlet connector | IEC 60320 C14 (Maximum 15 A, 250 V) |

## 7.4 Physical Characteristics

The Enterprise Manager appliance is a standard 1U rackmount.

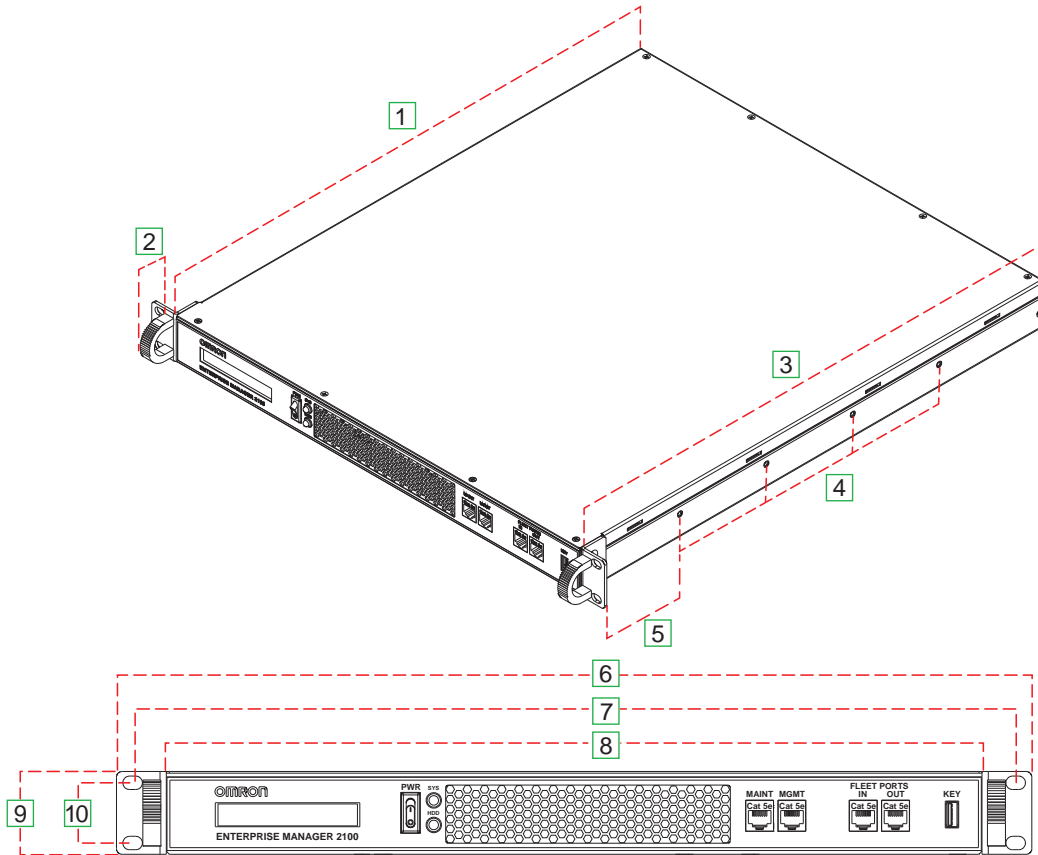

Figure 7-1. Dimensions

Table 7-4. Physical Characteristics

| Characteristic                      | Callout | Metric   | US           |
|-------------------------------------|---------|----------|--------------|
| Chassis enclosure depth             | 1       | 49.27 cm | 19.40 inches |
| Pull handle depth                   | 2       | 2.92 cm  | 1.15 inches  |
| Chassis and bracket depth           | 3       | 49.53 cm | 19.50 inches |
| Rail kit hole spacing               | 4       | 9.22 cm  | 3.63 inches  |
| Rail kit hole offset (from bracket) | 5       | 10.44 cm | 4.11 inches  |
| Max system width                    | 6       | 48.26 cm | 19.00 inches |
| Securing hole spacing               | 7       | 45.55 cm | 18.33 inches |



| Characteristic              | Callout | Metric                   | US                             |
|-----------------------------|---------|--------------------------|--------------------------------|
| Chassis enclosure width     | 8       | 43.00 cm                 | 16.93 inches                   |
| Chassis height (1U)         | 9       | 4.36 cm                  | 1.72 inches                    |
| Securing hole spacing depth | 10      | 3.18 cm                  | 1.25 inches                    |
| Appliance weight            | n/a     | 13.43 kg                 | 29.6 lbs                       |
| Shipping dimensions         | n/a     | 76 x 65.1 x 19.7<br>(cm) | 30 x 25.625 x 7.75<br>(inches) |

## 7.5 Connections

### Front

- 10/100/1000 Ethernet x 4
- USB for service use

### Rear

- USB x 4 for service use
- VGA (HDB15F) for service use
- IEC AC Power inlet



# Index

- 1
- 1U 80
- 2
- 24 VDC power
  - connecting 33
  - specifications 33
- A
- AC Power inlet 81
- access
  - fleet 48
  - SetNetGo 47
- account 48
  - Admin 48
  - MobilerPlanner 48
  - Operator 48
  - User 48
  - viewer 48
- active 39, 57
- Administrator 48
- Advanced Robotics Automation Management 13
- Advanced Robotics Command Language 14-15
- AIV 8, 64
  - assigned job 64
  - configuration 54
  - connecting to appliance 52
  - customizing 57
  - jobs 10, 64

---

- number supported 9
- required 64
- safety 15
- alert 17
- appliance 12
  - autosync 72
  - failed 14-15
  - remove 72
- ARAM 13
- ARAMCentral 13, 71
  - update 71
- ARCL 14-15
  - server 52
- assigned job 64
- auto-synchronize 11
- Automated Intelligent Vehicles 7
- automation
  - call button 59
  - system 14
- autonomous 13
- Autosync 14-15, 39
  - configure 54
  - operation 71
  - remove appliance 72
  - status 39, 57

## **B**

- boot errors 61

---

## C

- cabling
  - Ethernet 54
- call button 59
- chassis 80
- clear
  - queue 70
- client PC
  - Set IP 47
- clock 51
- configuration 7, 11, 45
  - AIV 54
  - overview 45
- configure
  - AIV 52
  - Autosync 54
  - fleet interface 50
  - management interface 50
  - network 49
  - secondary appliance 54
  - SetNetGo 47
- connect to SetNetGo 47
- connecting
  - AIV 52
  - network 40
  - power 33
- connections 45
  - network 40
- connectors and indicators 37

---

controls 37  
copyright 2  
Customer Service assistance 15  
customize AIV 57

## D

date and time 51  
debugInfo 77  
dimensions and specifications 80  
disabled 39  
display panel 37, 39, 61  
Disposal 20  
dock 57  
    preferred 58  
    separate 58  
docking station 10, 57  
domain server 50  
download map 64  
dropoff 64  
DSN 50  
dynamic route adjustments 11

## E

error  
    information 37  
    log 77  
Ethernet  
    cabling 54  
    connections 40  
    port 39  
    status 39

---

## F

failed 39

failed primary appliance 14-15

failed secondary appliance 15

fans 38

FIFO 10

firewall 76

fleet 11

- access 48
- Ethernet 38
- interface 50
- MobilePlanner settings 53

FLEET (ETH2) 56

Fleet administrative port 40

FLEET PORTS IN 56

flush queue 70

front power switch 39

## G

gateway 49

generate a map 64

## H

hard shutdown 62

hard stop 38

hazard 17

heartbeat 54

help 15, 77

How Can I Get Help? 15

---

## I

id  
    queud 65  
IEC 81  
indicators 37  
installation 15  
Installation 21  
IP  
    client PC 47

## J

job 10-11, 13, 64  
    assigned 64  
    dropoff 64  
    pickup 64  
    queue 64  
    required AIV 64  
    segment 64-65  
    states 66

## L

LAN 8, 10  
LCD 39  
LED 38  
    power 61  
license 10, 13  
    dongle 13  
    key 11  
log  
    error 77



---

## M

- mains power switch 39
- maintenance 15
  - Ethernet 38
  - port 40, 45
- management
  - Ethernet 38
  - interface 50
  - port 40
- managing queuing 64
- Managing Queuing 64
- Manuals 15
- Manufacturing Execution System 10
- map 9, 13
  - downloading 64
  - features 9
  - generating 64
  - workspace 64
- MARC 13
  - firmware 14
- MES 8, 11, 52
- MGMT 56
- mixed mode 58
- mobile robots 11
- Mobile Software
  - suite 14
- MobilePlanner 13-14, 45, 48
  - access 48
  - ARCL 52

---

fleet settings 53  
Operator Mode 13

## N

network 40  
    bandwidth 11  
    connecting to 40  
    gateway 49  
    settings 49  
    switches 11  
    troubleshooting 76  
Network Time Protocol 51  
notice, copyright 2  
NTP 51

## O

Operation 61  
operator 48  
options 45, 54  
overview  
    configuration 45  
    em2100 37

## P

password 47  
    ARCL 52  
payload 10  
PC client 11  
pending job queue 54  
peripherals 15, 59  
permissions 48

---

pickup 64

ports

- connections 40
- Ethernet 39

power

- cable 10
- LED 61
- nput 39
- off 61
- on 61
- supply 38
- switch 37, 61

preferred dock 58

primary 15

- appliance 11, 14, 54

primary appliance

- failed 14-15

## Q

queue 64

- flushing 70
- id 65
- managing 64
- parameters 68

queuing 13

queuing manager 7, 11

## R

rack-mount 10, 19

rail kit 19, 80

RAM 10

---

rear panel 38  
recharging 57  
Release Notes 12  
Remote I/O 13  
remove appliance 72  
required robot 64  
restart 37  
robot 7  
    fleet management 12  
    required 64

## S

safe power on 61  
safety 15, 17  
secondary 15  
    appliance 11, 14  
        configure 54  
secondary appliance 54  
    failed 15  
security 47  
segment 65  
separate dock 58  
service 16, 38  
SetNetGo 12, 45  
    access 47  
    connecting 47  
    security 47  
settings  
    fleet 53  
    network 49

---

shipping dimensions 81

shut down 61

- hard 62

software update 71

specifications 79

- 24 VDC power 79
- CPU 79
- dimensions 80
- hard drive 79
- memory 79
- processing 79

speech synthesis 58

SSL key 56

startup 39

status 37

- autosync 39, 57
- Autosync 39
- Ethernet 39
- jobs 66
- panel 39
- queue 66

status display panel 39

storage 10, 38

support 16, 77

support, contact information 15

SVGA 38

switch

- power 61

synchronize ethernet 38

---

system  
    clock 51  
    specifications 15

## **T**

technical support 77  
time 51  
touchscreen 14  
troubleshooting 76  
turn off power 61  
turn on power 61

## **U**

uninterruptable power supply 11  
unpacking 24  
update software 71  
UPS 11  
USB 12, 38, 81  
user 48

## **V**

VGA 81  
viewer 48  
voice 58

## **W**

warehouse management system 10  
Web management interface 47  
WEEE 20  
WiFi 8  
Windows client PC 12, 47

---

wireless 13  
    bandwidth 10, 12  
    Ethernet 12  
WMS 8, 10-11, 52  
workspace 9, 13  
    map 54, 64

**OMRON Corporation Industrial Automation Company**  
Kyoto, JAPAN

Contact: [www.ia.omron.com](http://www.ia.omron.com)

**Regional Headquarters**

**OMRON EUROPE B.V.**

Wegalaan 67-69, 2132 JD Hoofddorp  
The Netherlands  
Tel: (31)2356-81-300/Fax: (31)2356-81-388

**OMRON ASIA PACIFIC PTE. LTD.**

No. 438A Alexandra Road # 05-05/08 (Lobby 2),  
Alexandra Technopark,  
Singapore 119967  
Tel: (65) 6835-3011/Fax: (65) 6835-2711

**OMRON ELECTRONICS LLC**

2895 Greenspoint Parkway, Suite 200 Hoffman Estates,  
IL 60169 U.S.A.  
Tel: (1) 847-843-7900/Fax: (1) 847-843-7787

**OMRON ADEPT TECHNOLOGIES, INC.**

4550 Norris Canyon Road, Suite 150, San Ramon, CA 94583 U.S.A.  
Tel: (1) 925-245-3400/Fax: (1) 925-960-0590

**OMRON (CHINA) CO., LTD.**

Room 2211, Bank of China Tower, 200 Yin Cheng Zhong Road,  
PuDong New Area, Shanghai, 200120, China  
Tel: (86) 21-5037-2222/Fax: (86) 21-5037-2200

Authorized Distributor:

© OMRON Corporation 2019 All Rights Reserved.  
In the interest of product improvement,  
specifications are subject to change without notice.

Cat. No. I631-E-01

Printed in USA  
0119

14413-200 A