

OMRON

Digital LUPE
VC-DL100

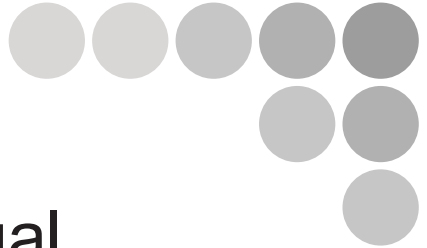

Operation Manual



Cat. No. SCNC-703B

INTRODUCTION

This manual contains important information necessary to use the Digital LUPE.

To ensure correct use, please read this manual thoroughly to deepen your understanding of the product. Please keep this manual in a safe place so that it can be referred to whenever necessary.

READ AND UNDERSTAND THIS DOCUMENT

Please read and understand this document before using the products. Please consult your OMRON representative if you have any questions or comments.

WARRANTY

OMRON's exclusive warranty is that the products are free from defects in materials and workmanship for a period of one year (or other period if specified) from date of sale by OMRON.

OMRON MAKES NO WARRANTY OR REPRESENTATION, EXPRESS OR IMPLIED, REGARDING NON-INFRINGEMENT, MERCHANTABILITY, OR FITNESS FOR PARTICULAR PURPOSE OF THE PRODUCTS. ANY BUYER OR USER ACKNOWLEDGES THAT THE BUYER OR USER ALONE HAS DETERMINED THAT THE PRODUCTS WILL SUITABLY MEET THE REQUIREMENTS OF THEIR INTENDED USE. OMRON DISCLAIMS ALL OTHER WARRANTIES, EXPRESS OR IMPLIED.

LIMITATIONS OF LIABILITY

OMRON SHALL NOT BE RESPONSIBLE FOR SPECIAL, INDIRECT, OR CONSEQUENTIAL DAMAGES, LOSS OF PROFITS OR COMMERCIAL LOSS IN ANY WAY CONNECTED WITH THE PRODUCTS, WHETHER SUCH CLAIM IS BASED ON CONTRACT, WARRANTY, NEGLIGENCE, OR STRICT LIABILITY.

In no event shall responsibility of OMRON for any act exceed the individual price of the product on which liability is asserted.

IN NO EVENT SHALL OMRON BE RESPONSIBLE FOR WARRANTY, REPAIR, OR OTHER CLAIMS REGARDING THE PRODUCTS UNLESS OMRON'S ANALYSIS CONFIRMS THAT THE PRODUCTS WERE PROPERLY HANDLED, STORED, INSTALLED, AND MAINTAINED AND NOT SUBJECT TO CONTAMINATION, ABUSE, MISUSE, OR INAPPROPRIATE MODIFICATION OR REPAIR.

SUITABILITY FOR USE

OMRON shall not be responsible for conformity with any standards, codes, or regulations that apply to the combination of products in the customer's application or use of the product. At the customer's request, OMRON will provide applicable third party certification documents identifying ratings and limitations of use that apply to the products. This information by itself is not sufficient for a complete determination of the suitability of the products in combination with the end product, machine, system, or other application or use.

The following are some examples of applications for which particular attention must be given. This is not intended to be an exhaustive list of all possible uses of the products, nor is it intended to imply that the uses listed may be suitable for the products:

- Outdoor use, uses involving potential chemical contamination or electrical interference, or conditions or uses not described in this document.
- Nuclear energy control systems, combustion systems, railroad systems, aviation systems, medical equipment, amusement machines, vehicles, safety equipment, and installations subject to separate industry or government regulations.
- Systems, machines, and equipment that could present a risk to life or property.

Please know and observe all prohibitions of use applicable to the products.

NEVER USE THE PRODUCTS FOR AN APPLICATION INVOLVING SERIOUS RISK TO LIFE OR PROPERTY WITHOUT ENSURING THAT THE SYSTEM AS A WHOLE HAS BEEN DESIGNED TO ADDRESS THE RISKS, AND THAT THE OMRON PRODUCT IS PROPERLY RATED AND INSTALLED FOR THE INTENDED USE WITHIN THE OVERALL EQUIPMENT OR SYSTEM.

PERFORMANCE DATA

Performance data given in this document is provided as a guide for the user in determining suitability and does not constitute a warranty. It may represent the result of OMRON's test conditions, and the users must correlate it to actual application requirements. Actual performance is subject to the OMRON Warranty and Limitations of Liability.

CHANGE IN SPECIFICATIONS

Product specifications and accessories may be changed at any time based on improvements and other reasons.

It is our practice to change model numbers when published ratings or features are changed, or when significant construction changes are made. However, some specifications of the product may be changed without any notice. When in doubt, special model numbers may be assigned to fix or establish key specifications for your application on your request. Please consult with your OMRON representative at any time to confirm actual specifications of purchased products.

DIMENSIONS AND WEIGHTS

Dimensions and weights are nominal and are not to be used for manufacturing purposes, even when tolerances are shown.

ERRORS AND OMISSIONS

The information in this document has been carefully checked and is believed to be accurate; however, no responsibility is assumed for clerical, typographical, or proofreading errors, or omissions.

PROGRAMMABLE PRODUCTS

OMRON shall not be responsible for the user's programming of a programmable product, or any consequence thereof.

COPYRIGHT AND COPY PERMISSION

This document shall not be copied for sales or promotions without permission.

This document is protected by copyright and is intended solely for use in conjunction with the product. Please notify us before copying or reproducing this document in any manner, for any other purpose. If copying or transmitting this document to another, please copy or transmit it in its entirety.

Meanings of Signal Words

The following signal words are used in this manual.



Indicates a potentially hazardous situation which, if not avoided, will result in minor or moderate injury, or may result in serious injury or death. Additionally there may be significant property damage.



Indicates a potentially hazardous situation which, if not avoided, may result in minor or moderate injury or in property damage.

Meanings of Alert Symbols

The following alert symbols are used in this manual.



Indicates prohibition when there is a risk of minor injury from electrical shock or other source if the product is disassembled.



Indicates general prohibitions for which there is no specific symbol.

Alert statements in this Manual

The following alert statements apply to the products in this manual. Each alert statement also appears at the locations needed in this manual to attract your attention.



Do not stare directly at the sun. It may cause permanent damage to vision.



Do not open the cover of the Digital LUPE. The inside high-voltage components may cause an electric shock.



After removing the lens unit from the camera, do not leave it in a place exposed to direct sunlight. Failure to do so may cause a fire.



Precautions for Safe Use

To ensure safe use of the product, the following points must be strictly observed.

1. Installation

- Take care not to drop the product. Dropping may result in breakdown.
- Make sure to tighten all installation screws securely.

2. Power Supply

- Do not use any AC power adapters other than the one supplied with the product.
- Use an AC power cable which is applicable to your power supply and voltage.
- Do not touch the power plug with wet hands. Doing so may result in electric shock.

3. Other

- If abnormalities, such as smoke, excessively hot external surface and odd smells, are found, immediately stop operation, turn OFF the power and disconnect the power plug from the AC power outlet. Repair of the product by the user is very dangerous, so contact OMRON.
- Do not let any foreign matter enter the product through vent holes. Entry of such matter may result in fire or electric shock.
- If the product is dropped or damaged, turn OFF the power and disconnect the power plug from the AC power outlet, and then contact OMRON. Continuing to use the product in such condition may result in fire.
- When observing the monitor continuously for long periods of time, make sure that you take sufficient breaks.
- Dispose of this product as industrial waste.

FCC Statement

This equipment has been tested and found to comply with the limits for a Class A digital device, pursuant to part 15 of the FCC Rules. These limits are designed to provide reasonable protection against harmful interference when the equipment is operated in a commercial environment. This equipment generates, uses, and can radiate radio frequency energy and, if not installed and used in accordance with the instruction manual, may cause harmful interference to radio communications. Operation of this equipment in a residential area is likely to cause harmful interference in which case the user will be required to correct the interference at his own expense.

Precautions for Correct Use

Please observe the following precautions to prevent failure to operate, malfunctions, or undesirable effects on product and product performance.

1. Installation Site

Do not install the Digital LUPE in locations subjected to the following conditions:

- Ambient temperature outside the rating
- Rapid temperature fluctuations (causing condensation)
- Relative humidity outside the range of 20 to 85%
- Presence of corrosive or flammable gases
- Presence of dust, salt, or iron particles
- Direct vibration or shock
- Inclined or unstable surface
- Reflection of external intense light (such as laser beams or arc-welding light)
- Direct sunlight or near heaters
- Presence of water, oil, and chemical agent splash
- Strong magnetic or electric field

2. Power Supply

- When performing maintenance or when not using for long periods of time, the power plug must be disconnected from the AC power outlet.
- Do not use the product with the power cable excessively bent.

3. Maintenance

- For your safety, turn OFF the power and remove various cables prior to maintenance.
- Clean the lens with a lens-cleaning cloth or air brush.
- Dirt on the product must be wiped off gently with a soft cloth.
- Dirt on the polarized filter must be removed using an air brush.
- Do not use thinner or benzene.

Features / Checking the Package Contents

Features of Digital LUPE

The Digital LUPE is designed to observe the object by displaying its enlarged images on the monitor.

- Provides electrically-operated zoom and auto focus functions.
Auto focus enables quick focus adjustment even for high-magnification observation.
- Allows switching to optimum magnification and lighting pattern with a single touch of a button.
Preset buttons that allow registration of observation conditions are provided. This enables quick switching to observation conditions suitable for the object.
- Provides 11 kinds of digital pattern lighting.
Digital pattern lighting that can be lit in 11 different directions is provided. The Digital pattern suitable for your applications can be selected (e.g. emphasizing roughness and scratches on the object's surface, eliminating irregular reflections on metal bars or the like.)
- Provides non-reflection mode to reduce irregular reflections on metal surfaces.
This mode is suitable for inspection of objects with strong irregular reflections.
- Provides a function that outputs high-quality images to a monitor or personal computer.

Checking the Package Contents

Before using the product, check that all the following items are present. It is extremely rare for any items to be missing, but should this occur contact the nearest OMRON representative.

Digital LUPE main unit

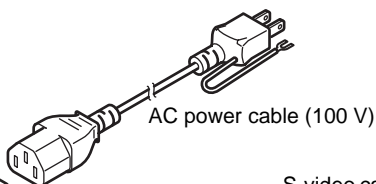
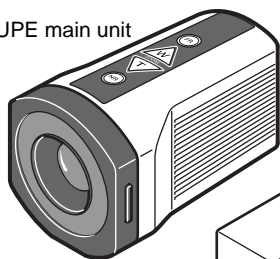

AC power cable (100 V)

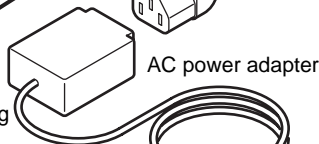

AC power adapter

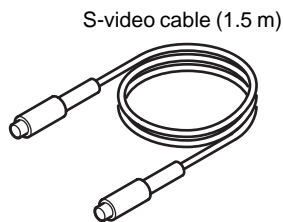

S-video cable (1.5 m)

Two kinds of corresponding lenses (x50 and x100)

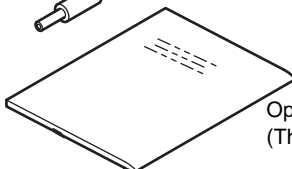
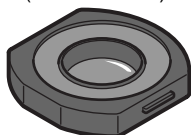

Operation Manual
(This manual)

* The magnification is written on each lens.
A corresponding lens (x50) is attached to main unit when shipping from the factory.

* The Digital LUPE stand must be purchased separately.

CONTENTS

READ AND UNDERSTAND THIS DOCUMENT	1
Meanings of Signal Words	4
Precautions for Safe Use	5
Precautions for Correct Use	7
Features / Checking the Package Contents	8
Features of Digital LUPE	8
Checking the Package Contents	8
Quick Start	10
Part Names	12
Installation and Connections	14
How to Use the Digital LUPE	15
Preparation	15
Adjusting the Height of the Digital LUPE	16
Changing the Magnification Ratio	17
Adjusting the Light for the Object	18
Reducing Irregular Reflections	19
Changing the Magnification and Lighting Pattern in a Single Operation	20
Stopping the Video	21
Adjusting White Balance	22
Fixing the Focus	22
Registering Observation Conditions	23
Replacing the Lens	25
Maintenance	26
Troubleshooting	27
Specifications	28
Digital LUPE	28
Digital LUPE Stand	30
Revision History	31

Quick Start

- 1 Set the Digital LUPE. (p.14)
Mount the Digital LUPE on a Stand (Option: Model VC-DLST) and install it in place.
- 2 Connect the AC power adapter to the _____
- 3 Connect the AC power cable to a wall socket. (p.14)
- 4 Connect the Digital LUPE with the monitor _____ using the S-Video cable. (p.14)

- 5 Turn on the Power and Lights. (p.15)
Turn on the power of monitor.

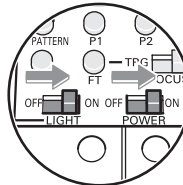

- 6 Set the object in place and adjust the height seeing the image. (p.16)
Set the [FOCUS] switch to AUTO, set the magnification to max. value and then adjust the height.

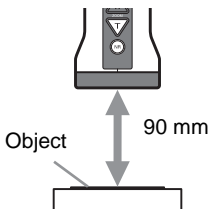



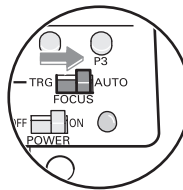

When a corresponding lens (x50) is used:



The lighting pattern can be switched over using the [L-PATTERN] button. (p.18)

Typical lighting patterns:

 <p>Lights up the object uniformly</p>	 <p>Emphasizes roughness</p>	 <p>Eliminates irregular reflectinos of the metal bar or the like.</p>	 <p>Emphasizes scratches.</p>	<div style="display: flex; align-items: center;"> <div style="width: 15px; height: 10px; background-color: white; border: 1px solid black; margin-right: 5px;"></div> Lit </div> <div style="display: flex; align-items: center; margin-top: 5px;"> <div style="width: 15px; height: 10px; background-color: gray; border: 1px solid black; margin-right: 5px;"></div> Lit off </div>
---	---	---	--	---

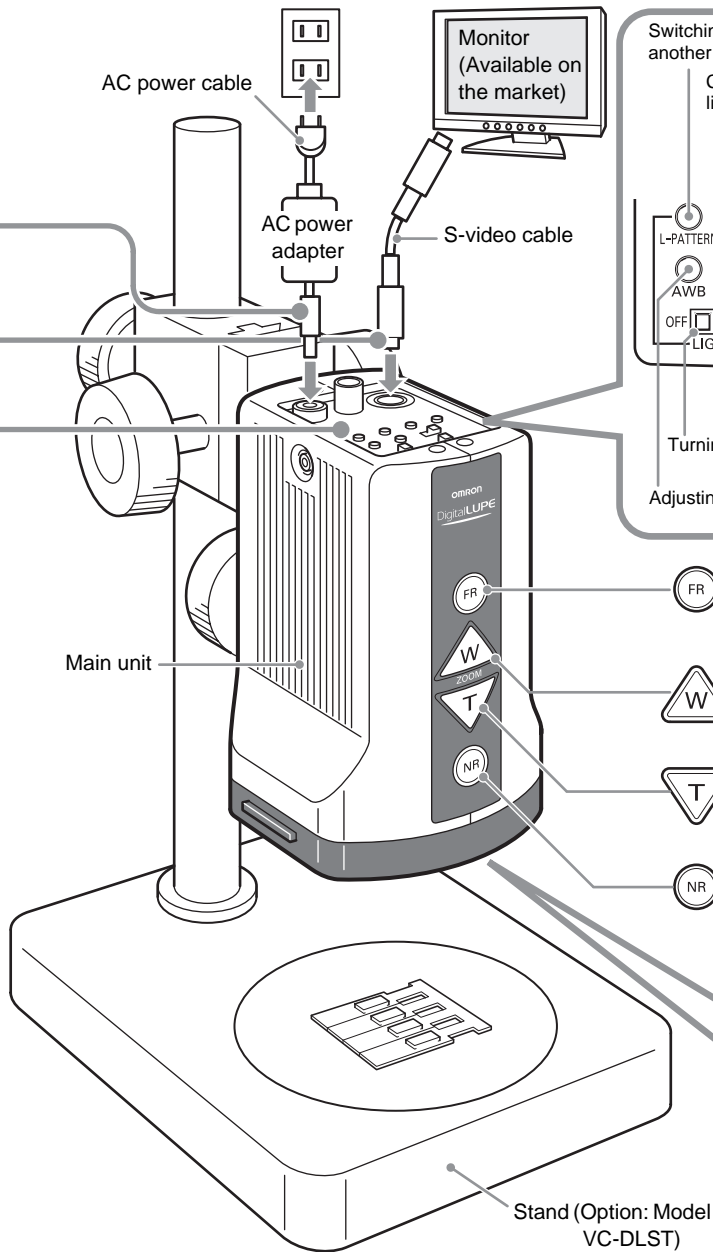

Switching from one lighting pattern to another (p.18)

Changing the magnification ratio and lighting pattern (p.20, 23)





Switching from one focus mode to another (p.22)

Fixing the focus under the focus mode "TRG" (semi auto focus) (p.22)

Turning the power ON or OFF (p.15)

Turning the lights ON or OFF (p.15)



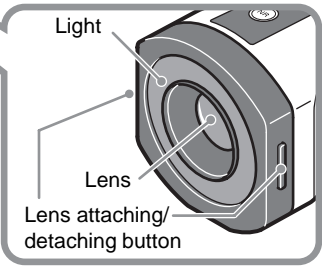

Adjusting white balance (p.22)

-  FR button (p.21)
Stops the video.
By depressing this button, the frozen state will be released.
-  Zoom W button (p.17)
Decreases the image of the object in size.
-  Zoom T button (p.17)
Increases the image of the object in size.
-  NR button (p.19)
Reduces irregular reflections on the object resulting in a smooth image.

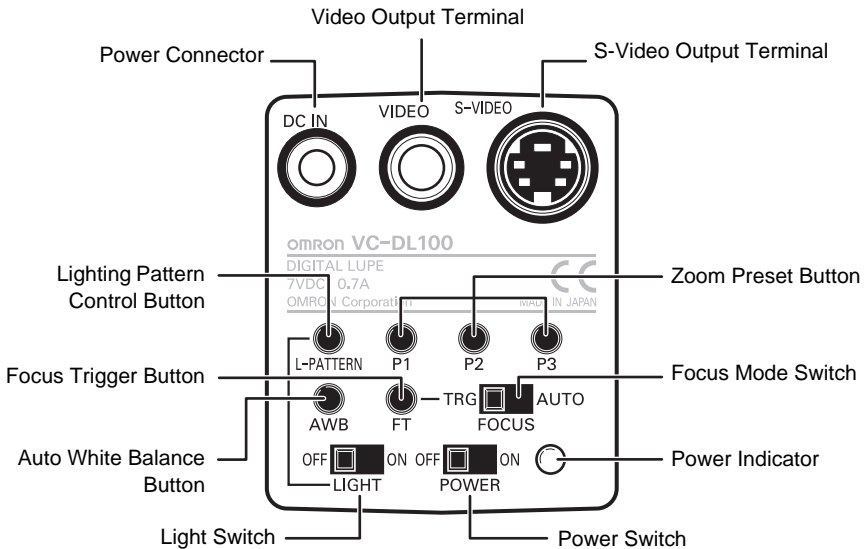
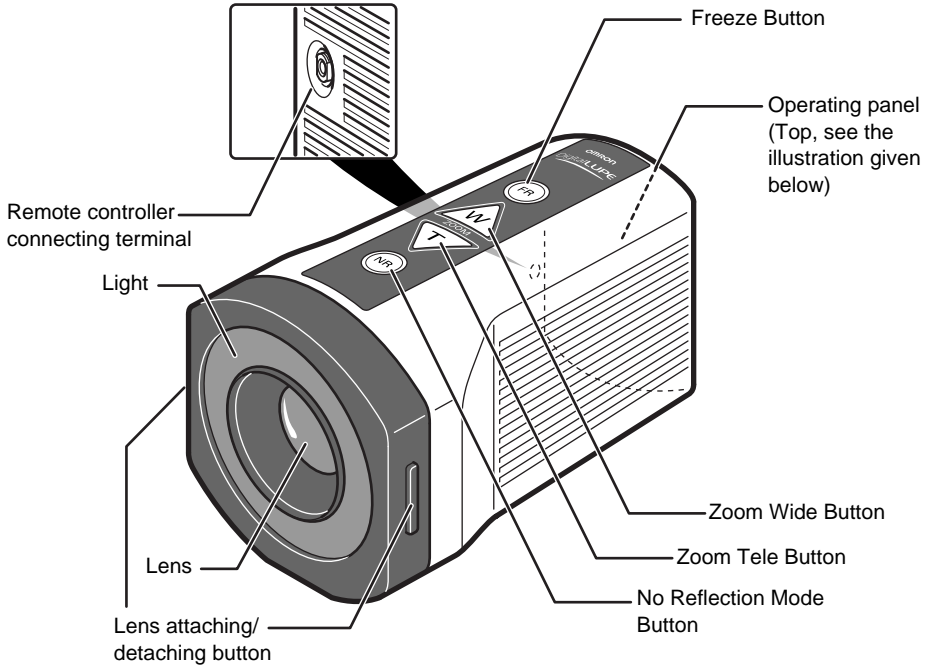

Part Names



Name	Function
W	Decreases the magnification ratio. Pressing this button reduces the object's image.
T	Increases the magnification ratio. Pressing this button enlarges the object's image.
FR	Stops the video. Pressing this button stops the video displayed on the monitor. Pressing the button again restarts the video.
NR	Switches to non-reflection mode. Pressing this button reduces irregular reflections on the object's surface. Pressing the button again turns off non-reflection mode and returns to normal mode.
POWER	Turns ON/OFF the power to the Digital Lupe.
LIGHT	Turns ON/OFF the light of the Digital Lupe.
FOCUS	Switches between auto focus (AUTO) and semi auto focus (TRG).
FT	Used for focus adjustment during semi auto focus mode. Pressing this button switches to auto focus mode for a certain period of time without changing the magnification and adjusts focus.
AWB	Used for white balance adjustment.  p.22
L-PATTERN	Switches the lighting pattern each time this button is pressed.  p.18
P1, P2, P3	Used to switch to the magnification and lighting pattern registered to the preset buttons.  p.20
DC IN	Connect the AC power adapter (supplied with the product) to this connector.
S-VIDEO	Connect the S-video cable (supplied with the product) to output the S-video signal.
VIDEO	Used to output video signal by connecting a commercially available video cable to this connector.
Lens	Two kinds of corresponding lenses are provided: x50 and x100
Remote controller connecting terminal	 p.28





When button (switch) is operated, its name will appear for a few seconds in the right side of the monitor. (POWER and LIGHT are not displayed.) "FR" is displayed while the video is stopped, but the product can be set so that none is displayed even if the video is stopped.

CHECK!

 p.21

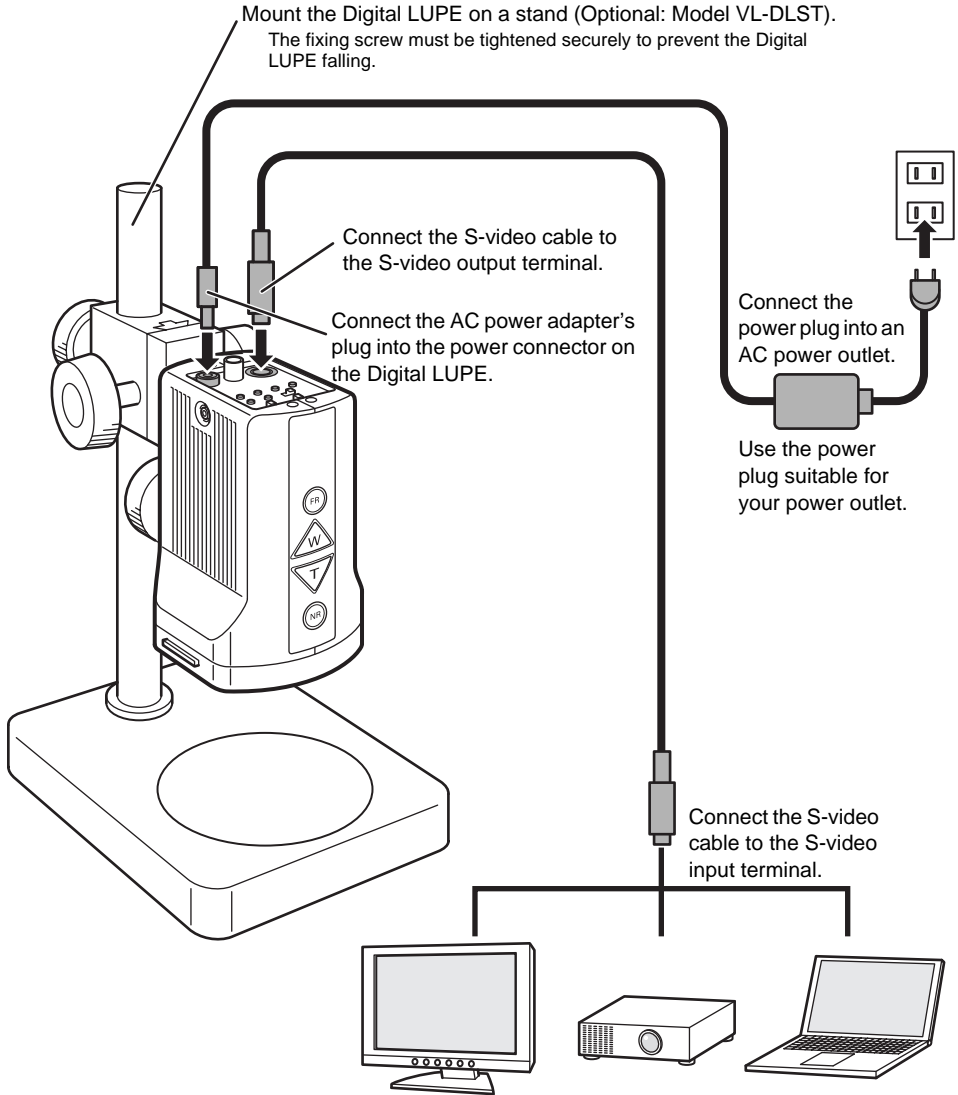
Installation and Connections



-  **CHECK!**
- If you want to record the video taken by the Digital LUPE as video data, connect the Digital LUPE to a video capture board installed on the personal computer.
 - The video can also be output using a commercially available video cable. For this, the cable must be connected to the video input terminal of a monitor etc.
 - S-video output and video output can be used simultaneously.

How to Use the Digital LUPE

Preparation

1. Turn ON the power.

Also turn ON the devices (e.g. monitor) connected to the Digital LUPE.

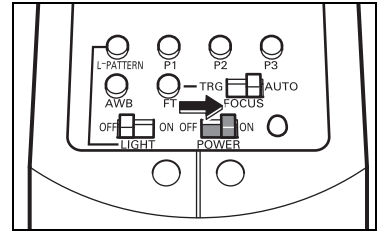

2. Set the target object in place.

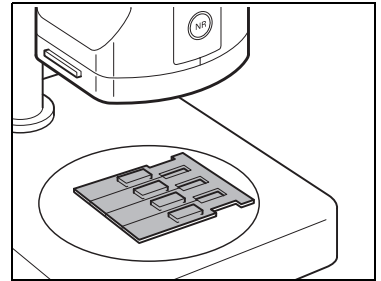

3. Turn ON the lights.

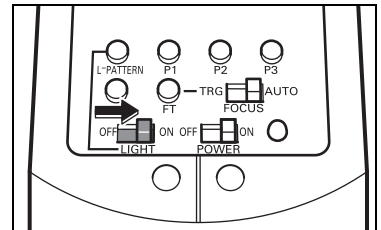

4. Check the image.



CHECK!

- To make the displayed image clear, adjust the brightness and color tone of the monitor and personal computer. For the setting method, refer to the manual supplied with these products.
- If focus cannot be adjusted, check whether the distance between the Digital LUPE and the object is correct.



Adjusting the Height of the Digital LUPE
p.16

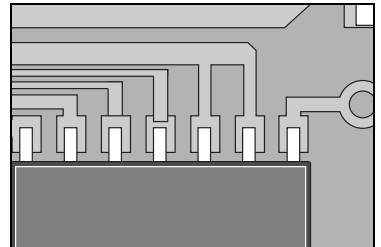

How to Use the Digital LUPE

Adjusting the Height of the Digital LUPE

To take the best performance of the Digital LUPE, the distance from the object's surface to the digital LUPE needs to be adjusted.

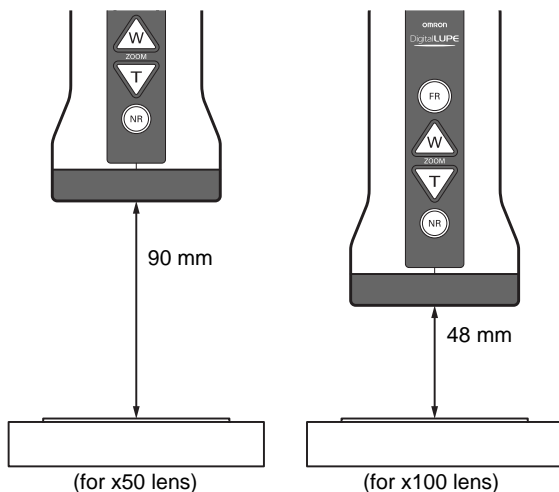

For Smooth Height Adjustment

1. Set the target object in place.
2. Turn ON the [FOCUS] switch.
The Digital LUPE will be placed in auto focus mode.
3. Press  to set the maximum magnification ratio.
4. Adjust the height while observing the monitor image.

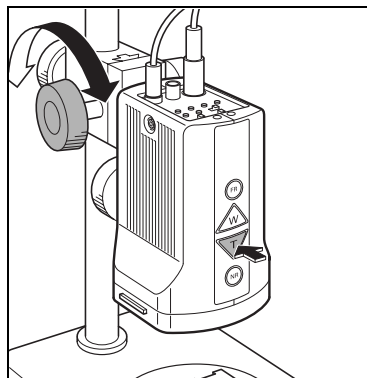

The Digital LUPE must be secured to the stand at the focused position.



Changing the Magnification Ratio



Change the magnification ratio so that it suits the object.

To increase the magnification ratio

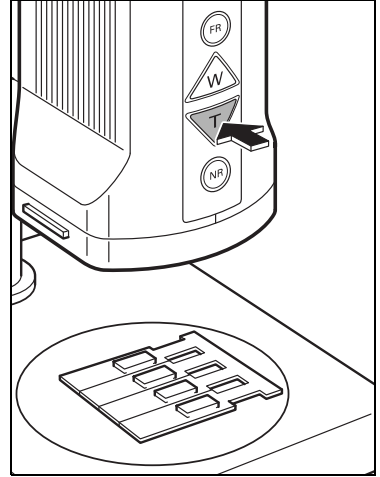
1. Press ZOOM .
The image of the object will increase in size.
2. Release  when the image is enlarged to the desired size.



To decrease the magnification ratio

1. Press ZOOM .
The image of the object will decrease in size.
2. Release  when the image is reduced to the desired size.

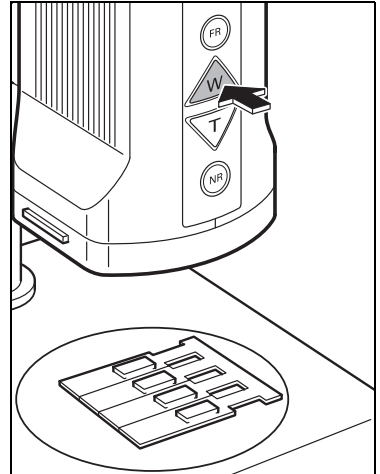

How to Use the Digital LUPE

Adjusting the Light for the Object

The ring-shaped light attached to the Digital LUPE is divided into four blocks. By turning ON/OFF certain blocks, 11 lighting patterns can be provided to light up the object (digital pattern lighting).

Select a suitable lighting pattern that lights up the inspection area clearly.

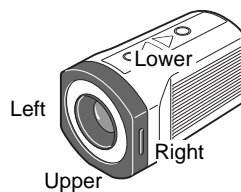

Digital Pattern Lighting Type

Effect	Pattern No. and Lighting Status				
Lights up the object uniformly.	00: All lit				
Emphasizes roughness.	01: Upper left	02: Upper right	03: Lower right	04: Lower left	
	Eliminates irregular reflections such as the metal bar or the like	05: Upper/lower	06: Right/left		
Emphasizes scars.	07: Diagonal (upper)	08: Diagonal (lower)	09: Diagonal (left)	10: Diagonal (right)	



Sufficient effect may not be obtained depending on the material and shape of the object.

CHECK!

To switch from one lighting pattern to another

1. Press the [L-PATTERN] button.

The lighting pattern switches from one to another in the pattern number order. In addition, the pattern number is displayed in the right side of the monitor.

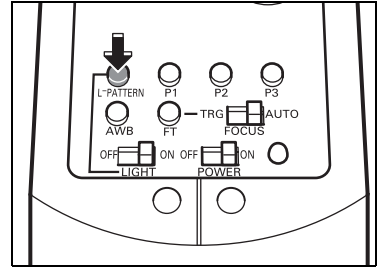

2. Press down the [L-PATTERN] button repeatedly until the desired lighting pattern is obtained.



The lights will not come on unless the [LIGHT] switch is ON.

CHECK!

Reducing Irregular Reflections

If the image is difficult to see since the metal surface of the object causes irregular reflections, set the Digital LUPE in non-reflection mode. The irregular reflections will be reduced, resulting in a smooth image.



To obtain sufficient effect of non-reflection mode, make sure that no lights, except for the light from the Digital LUPE, enter. Entry of external light may hinder elimination of irregular reflections.

CHECK!

1. Press (NR).

The mode will be switched to non-reflection mode.

2. To return to normal mode, press (NR) again.

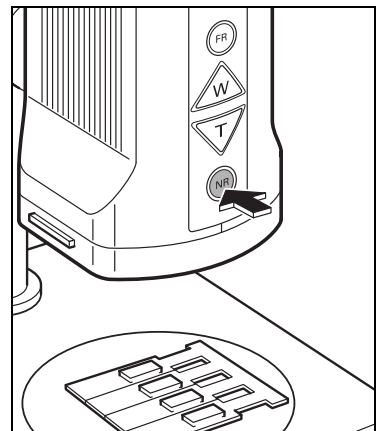

How to Use the Digital LUPE

Changing the Magnification and Lighting Pattern in a Single Operation

Switching to optimum magnification and lighting pattern can be performed with a single touch of a button.

Pressing a preset button (P1, P2, P3) restores the magnification and lighting pattern registered to that button.

Default (factory) setting

Button	Magnification	Lighting
P1	Low (x2)	All lit
P2	Middle (x5)	All lit
P3	High (x7.5)	All lit



It is possible to register the desired magnification and lighting pattern to each button.



Registering Observation Conditions p.23

To change the magnification and lighting pattern with a single touch of a button

Press the desired preset button.

The magnification and lighting pattern registered to that button will be set.

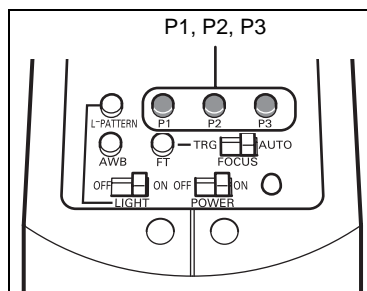

Do not hold down a preset button for more than three seconds. Failure to do so will register the current magnification and lighting pattern to that preset button.

Stopping the Video

The video currently displayed in the monitor can be stopped.

This is useful when you want to keep the same observation conditions for a certain section of the object so that you have enough time to observe it carefully.

1. Display the section of the object at which you want to stop the video.
2. Press **FR**.
The monitor video will stop.
3. To make the video play again, press **FR** again.

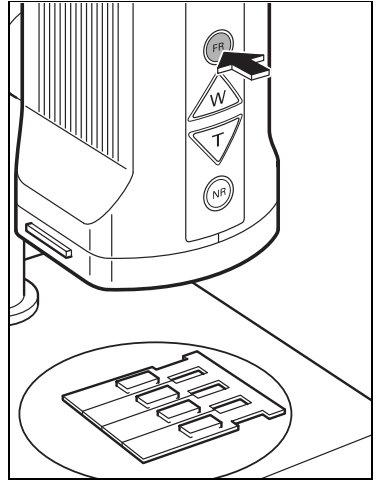

"FR" is displayed on the monitor while the video is at stop. If you won't display the "FR", make a setting as follows.

CHECK!

1. Turn OFF the power.
2. Then, turn it ON while holding down the **FR**.
3. When "FR DISP ON/OFF" appears on the monitor, release the **FR** from your finger.

If you want to display the "FR" again on the monitor, perform the same steps as above.

How to Use the Digital LUPE

Adjusting White Balance

This section explains how to adjust white balance of the Digital LUPE.

1. Display a white object (e.g. paper, cloth) on the monitor.
2. Press the [AWB] button with focus adjusted.

“AWB” will flash for approximately five seconds in the right corner of the monitor. When “AWB” disappears, adjustment of white balance is complete if the white object is displayed white in the monitor.

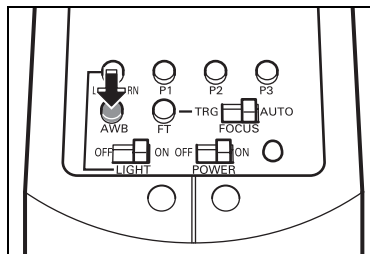

- Keep the object still while “AWB” is flashing on the monitor.
- White balance may not be adjusted at once depending on the operating conditions. In this case, press the [AWB] button again.

CHECK!



Fixing the Focus

When operating the Digital LUPE repeatedly with the same magnification, the object can be observed at fixed focus by setting the focus mode to “TRG” (semi auto focus). The “TRG” also lightens the mechanical load to the product compared with the auto focus, resulting in longer product life.

Set the [FOCUS] switch to “TRG”.

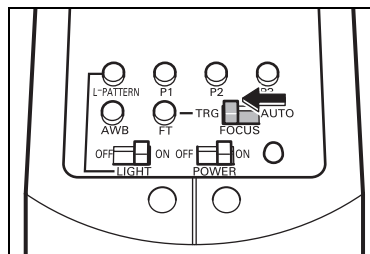
Focus will be fixed.





- About the Semi Auto Focus
When the magnification is changed by pressing ,  or a preset button, auto focus will be activated for a certain period of time (approximately five seconds) to adjust focus. If you want to adjust focus without changing the magnification, press the [FT] button. This will activate auto focus for a certain period of time to adjust focus.

CHECK!

Registering Observation Conditions

The procedure for changing to appropriate magnification and lighting pattern by pressing a preset button (P1, P2, P3) is explained on p.20. Now, this section explains how to register the desired the magnification and lighting pattern to preset buttons.

1. Press  or  to obtain the magnification to be registered.

Observe the image, and make sure that the image is in focus.

2. Press the [L-PATTERN] button to switch the lighting pattern to the one to be registered.

The lighting pattern switches from one to another in the pattern number order.

 Adjusting the Light for the Object p.18

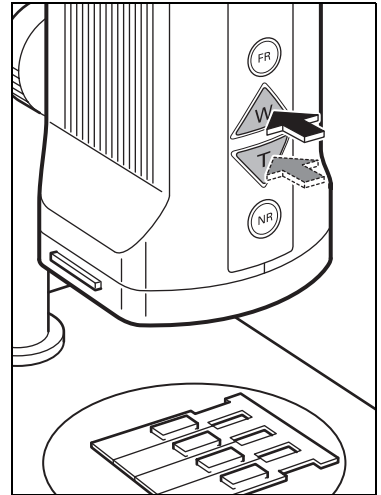

3. Hold down the preset button showing the preset magnification and lighting pattern you want to register for more than 3 seconds.

“REC” will appear in the monitor and registration is now complete.

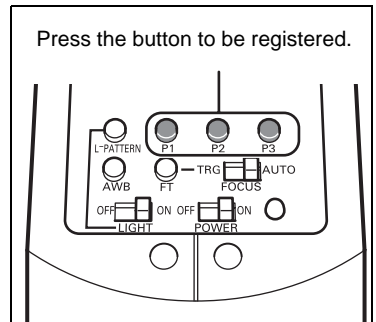

How to Use the Digital LUPE

To restore the default observation conditions

Once observation conditions (magnification and lighting pattern) are registered, the previous conditions cannot be restored. However, it is still possible to restore the default conditions (factory settings).

 Default (factory) setting p.20



This operation will restore the default observation conditions for every preset button.

CHECK!

1. Turns OFF the power.

Turns OFF the [POWER] switch.

2. Turn ON the [POWER] switch while holding down the [P1] and [P3] buttons.

3. When the image and “INITIALIZED” appear on the monitor, release the buttons from your fingers.

This will restore the default observation conditions for every preset button.

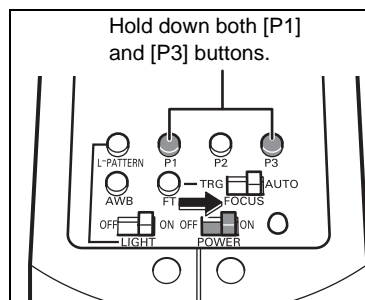

If you release the button before displaying “INITIALIZED” on the monitor, it is not possible to restore the default observation conditions (factory settings).

CHECK!

Replacing the Lens

Two lenses (x50, x100) are supplied with the Digital LUPE. Use the lens suitable for the object.

- Removing the Lens

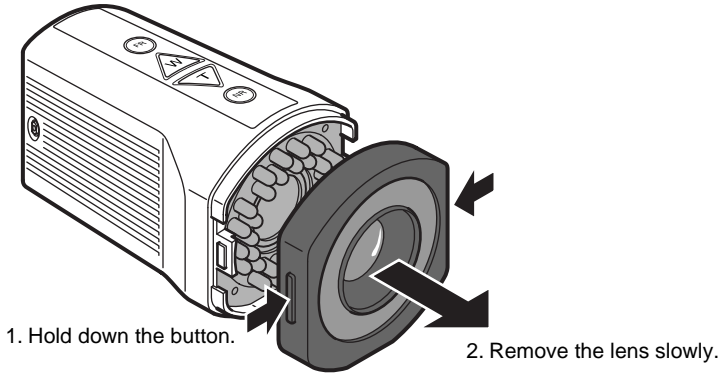

- Attaching a Lens

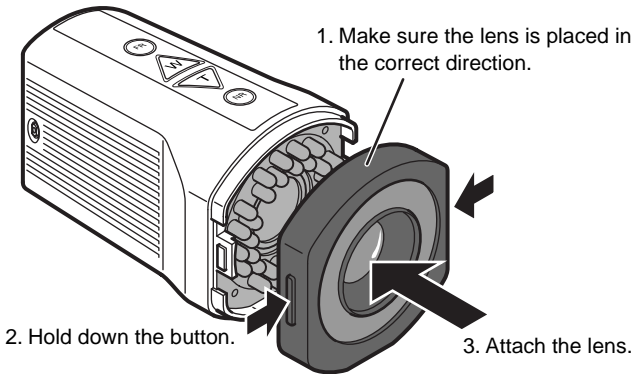

Maintenance

To use the Digital LUPE usually under good conditions, perform the following checks.



CHECK!

- Prior to maintenance, turn OFF the power and remove the various cables.
- Do not use thinner or benzine.

Dirt on the lens: Clean the lens with a lens-cleaning cloth or air brush.

Dirt on the polarized filter: Remove the dirt with an air brush.

Dirt on the product: Wipe off the dirt gently with a soft cloth.

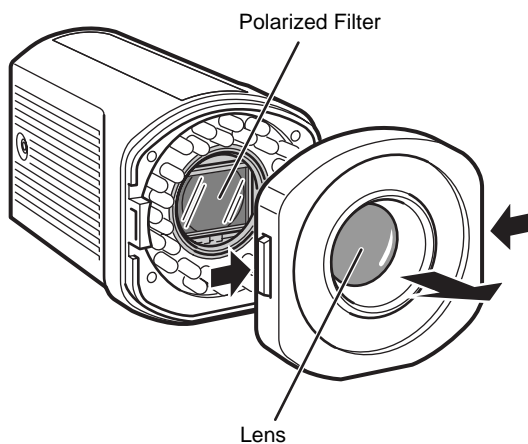

Troubleshooting

When abnormal symptom appears with the Digital LUPE, refer to the following table to take necessary actions.

If the same symptom continues, contact OMRON.

Symptom	Action	Reference
No image on the monitor	<ul style="list-style-type: none"> • Check that both monitor and Digital LUPE are powered ON. • Check that the video output is switched to the connected video channel. • Check that the video cable and power plug are connected properly. 	<p>p.15</p> <p>—</p> <p>p.14</p>
Incorrect color shade	<ul style="list-style-type: none"> • Check color tone of the monitor has been adjusted. • Check that white balance is correct. 	<p>p.15</p> <p>p.22</p>
Not possible to adjust focus.	<ul style="list-style-type: none"> • Check that the distance to the object is correct. • Check that the lens is attached correctly. • Check that the height was adjusted when the lens was exchanged. • Check that the lens is clean. • Check that Digital LUPE is not set in freeze mode. 	<p>p.16</p> <p>p.25</p> <p>p.16</p> <p>p.26</p> <p>p.21</p>
Entire image is too bright.	<ul style="list-style-type: none"> • Check that brightness of the monitor has been adjusted. • Check that white balance is correct. 	<p>p.15</p> <p>p.22</p>
Buttons do not function.	<ul style="list-style-type: none"> • Check that Digital LUPE is not set in freeze mode. 	p.21
Object causes irregular reflections even in non-reflection mode.	<ul style="list-style-type: none"> • Check that there is no entry of external light. When operating, make sure that no lights, except for the light from Digital LUPE, enter. 	p.19
Preset buttons do not function properly.	<ul style="list-style-type: none"> • Check that the observation conditions registered to the preset buttons are appropriate. Restore the default observation conditions for the preset buttons, and then register the desired conditions again. 	p.23, 24
Video cannot be recorded by PC.	Refer to the manual of your personal computer and video capture board.	—

Specifications

Digital LUPE

VC-DL100

Performance specifications	Image sensor	1/4 type CCD
	Number of effective pixels	Approx. 380,000 pixels
	Lens	10x optical zoom
	White Balance	One-push auto white balance
	AE Control	Full auto
	Focusing System	Semi-auto/Auto
	Observation Assistant Function	Freeze mode, Non-reflection mode
	Light	32 White LEDs, Digital Pattern Lighting mode
	Control input	Zoom-T, W, FR (for 2.5mm 4-Conductor Plug)
	Video output	VBS : 1.0Vp-p (sync. negative), Y/C Output NTSC format
General specifications	Operating temperature/humidity	0 to +40°C / 20 to 85%RH (with no condensation)
	Storage temperature/humidity	-10 to +50°C/20 to 85%RH (with no condensation)
	Supply voltage/Power consumption	DC7V/5W AC adapter: AC100 to 240V
	External dimensions	76 × 77.5 × 127.5mm
	Weight	Approx. 300 g

To use a remote controller

The Digital LUPE has a terminal for remote controller, enabling you to operate some buttons using your remote controller. To connect a remote controller, a 4-prong plug (2.5 diameter) must be used.

An example of the buttons that can be operated by the remote controller and the pin assignment is given below.

Plug Pin Assignment

Plug Pin Assignment

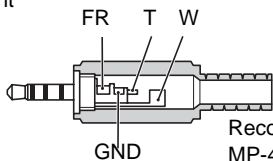

Recommended Plug:
MP-425 (2.5φ, 4-conductor) Marushin electric mfg. co., ltd

Circuit Diagram

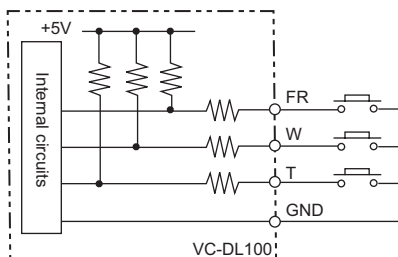

FR: Freeze button
W: Zoom wide button
T: Zoom tele button

(Unit: mm)

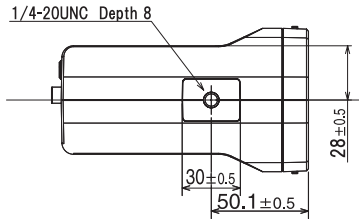
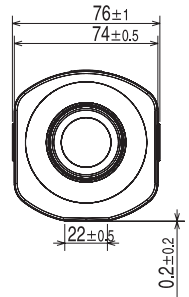
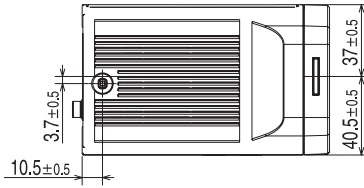
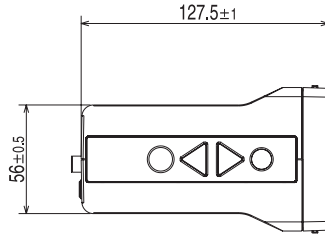
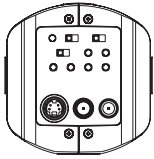

Digital LUPE Stand

VC-DLST

■ Stand

(Unit: mm)

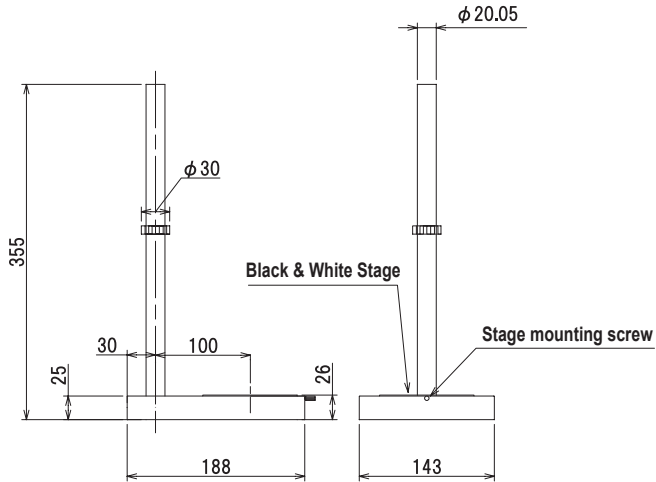

■ Adjustment Unit

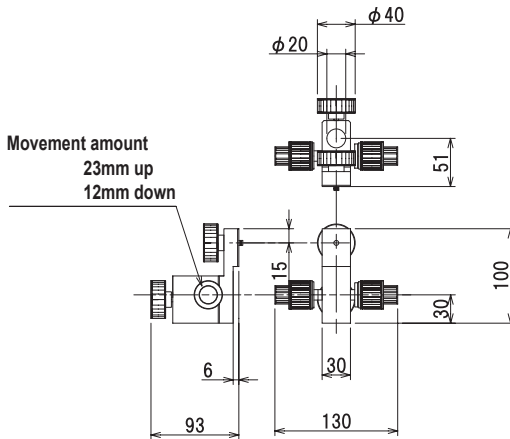

Weight: Approx. 1,9kg

* Including the Adjustment Unit and Black & White Stage.

Revision History

A manual revision code and reprint code appear as a suffix to the catalog number at the bottom of the front and back covers of this manual.

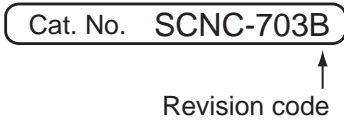

Revision code	Date	Revised content
A	Sep. 2004	Original production
B	Jan. 2005	Added a wiring diagram for the remote controller and a diagram with external dimensions for the stand.
B	Jun. 2005	Minor change (P. 30)

OMRON Corporation
Industrial Automation Company

Application Sensors Division
Sensing Devices and Components Division H.Q.

Shiokoji Horikawa, Shimogyo-ku,
Kyoto, 600-8530 Japan
Tel: (81)75-344-7068/Fax: (81)75-344-7107

Regional Headquarters

OMRON EUROPE B.V.

Sensor Business Unit,
Carl-Benz-Str. 4, D-71154 Nufringen,
Germany
Tel: (49)7032-811-0/Fax: (49)7032-811-199

OMRON ELECTRONICS LLC

1 East Commerce Drive, Schaumburg, IL 60173
U.S.A.
Tel: (1)847-843-7900/Fax: (1)847-843-8568

OMRON ASIA PACIFIC PTE. LTD.

83 Clemenceau Avenue,
#11-01, UE Square,
239920 Singapore
Tel: (65)6835-3011/Fax: (65)6835-2711

OMRON CHINA CO., LTD. BEIJING OFFICE

Room 1028, Office Building,
Beijing Capital Times Square,
No. 88 West Chang'an Road,
Beijing, 100031 China
Tel: (86)10-8391-3005/Fax: (86)10-8391-3688

Authorized Distributor: